



COLORADO

Department of Transportation

CONSTRUCTION MANUAL

2019

FOREWORD

The *CDOT Construction Manual* is an operational manual of the Colorado Department of Transportation (CDOT). It defines the criteria and procedures to be used by engineering personnel in the administration of construction contracts. The *Manual* was prepared and is maintained by the Contracts and Market Analysis Branch under the authority of, and at the direction of, the Chief Engineer. Although the *Manual* follows the general outline of the Standard Specifications, it is not a specification and should not be interpreted as such. Any section references are specific to this *Manual* unless otherwise noted. Suggestions and/or comments for improvement, clarification, correction, and/or inclusion of material in the *Manual* are welcome. Please forward your comments to your Area Engineer in the Contracts and Market Analysis Branch.

The instructions and procedures in this *Manual* are written and intended for use by Project Engineers and Project Inspectors.

TRADEMARKS

AASHTOWare® is a registered trademark of the American Association of Highway and Transportation Officials (AASHTO). It is a suite of software for transportation projects.

Preconstruction is a commonly used name for AASHTOWare Project Preconstruction™.

SiteManager is a commonly used name for AASHTOWare Project SiteManager.

Adobe and Acrobat are either registered trademarks or trademarks of Adobe Systems Incorporated in the United States and other countries.

MicroStation® is a registered trademark of Bentley Systems, Incorporated.

ProjectWise® is a registered trademark of Bentley Systems, Incorporated.

REVISIONS

The *Manual* will be revised as methods, materials, policies, procedures, specifications, and the industry change. CDOT will make revisions to the *Manual* available at

https://www.codot.gov/business/designsupport/bulletins_manuals

Suggested or required revisions shall be approved and made by the Area Engineers only.

Revisions are notated as shaded text.

TABLE OF CONTENTS

Contents

SECTION 100	GENERAL PROVISIONS	100-1
SECTION 101	GENERAL GUIDELINES	100-2
SECTION 102	BIDDING REQUIREMENTS AND CONDITIONS	100-9
SECTION 103	AWARDED AND EXECUTION OF CONTRACT	100-13
SECTION 104	SCOPE OF WORK	100-15
SECTION 105	CONTROL OF WORK	100-19
SECTION 106	CONTROL OF MATERIAL.....	100-48
SECTION 107	LEGAL RELATIONS AND RESPONSIBILITY TO THE PUBLIC	100-51
SECTION 108	PROSECUTION AND PROGRESS.....	100-73
SECTION 109	MEASUREMENT AND PAYMENT	100-99
SECTION 120	DOCUMENTATION REQUIREMENTS	100-109
SECTION 121	FINAL PROJECT RECORDS.....	100-176
SECTION 122	LOCAL AGENCY PROJECT ADMINISTRATION.....	100-198
SECTION 123	COMBINED BRIDGE ENTERPRISE AND CDOT FUNDED PROJECTS.....	100-202
SECTION 200	EARTHWORK	200-1
Section 200	EARTHWORK	200-2
SECTION 201	CLEARING AND GRUBBING	200-6
SECTION 202	REMOVAL OF STRUCTURES AND OBSTRUCTIONS	200-8
SECTION 203	EXCAVATION AND EMBANKMENT.....	200-10
SECTION 206	EXCAVATION AND BACKFILL FOR STRUCTURES.....	200-17
SECTION 207	TOPSOIL.....	200-20
SECTION 208	EROSION CONTROL.....	200-22
SECTION 209	WATERING AND DUST PALLIATIVES.....	200-28
SECTION 210	RESET STRUCTURES.....	200-30
SECTION 212	SEEDING, FERTILIZER, AND SODDING	200-33
SECTION 213	MULCHING	200-36
SECTION 214	PLANTING.....	200-39
SECTION 215	TRANSPLANTING	200-42
SECTION 216	SOIL RETENTION COVERING.....	200-44

TABLE OF CONTENTS

SECTION 217 HERBICIDE TREATMENT	200-45
SECTION 250 ENVIRONMENTAL, HEALTH, AND SAFETY MANAGEMENT	200-47
SECTION 300 BASES	300-1
SECTION 300 BASES	300-2
SECTION 304 AGGREGATE BASE COURSE	300-4
SECTION 306 RECONDITIONING	300-6
SECTION 307 LIME TREATED SUBGRADE	300-7
SECTION 400 PAVEMENTS	400-1
SECTION 400 PAVEMENTS	400-2
SECTION 401 PLANT – MIX PAVEMENTS – GENERAL.....	400-3
SECTION 402 RESERVED.....	400-17
SECTION 403 HOT – MIX ASPHALT.....	400-18
SECTION 404 RESERVED.....	400-19
SECTION 405 HEATING AND SCARIFYING TREATMENT	400-20
SECTION 406 COLD ASPHALT PAVEMENT (RECYCLE).....	400-22
SECTION 407 PRIME COAT, TACK COAT, AND REJUVENATING AGENT	400-25
SECTION 408 JOINT AND CRACK SEALANT.....	400-27
SECTION 409 CHIP SEAL	400-29
SECTION 410 RESERVED.....	400-33
SECTION 411 ASPHALT MATERIALS	400-34
SECTION 412 PORTLAND CEMENT CONCRETE PAVEMENT	400-35
SECTION 413 RESERVED.....	400-47
SECTION 414 RESERVED.....	400-47
SECTION 415 RESERVED.....	400-47
SECTION 416 RESERVED.....	400-47
SECTION 417 RESERVED.....	400-47
SECTION 418 RESERVED.....	400-47
SECTION 419 RESERVED.....	400-47
SECTION 420 GEOSYNTHETICS.....	400-48
SECTION 500 STRUCTURES	500-1
SECTION 501 STEEL SHEET PILING	500-2
SECTION 502 PILING.....	500-4

TABLE OF CONTENTS

SECTION 503 DRILLED CAISSONS	500-10
SECTION 504 WALLS	500-14
SECTION 505 RESERVED.....	500-16
SECTION 506 RIPRAP, GABIONS, AND SLOPE MATTRESS	500-17
SECTION 507 SLOPE AND DITCH PAVING.....	500-19
SECTION 508 TIMBER STRUCTURES.....	500-22
SECTION 509 STEEL STRUCTURES	500-24
SECTION 510 STRUCTURAL PLATE STRUCTURES	500-27
SECTION 511 RESERVED.....	500-29
SECTION 512 BEARING DEVICES	500-30
SECTION 513 RESERVED.....	500-32
SECTION 514 PEDESTRIAN AND BIKEWAY RAILING	500-33
SECTION 515 WATERPROOF MEMBRANE	500-35
SECTION 516 DAMPPROOFING	500-37
SECTION 517 WATERPROOFING	500-39
SECTION 518 WATERSTOPS AND EXPANSION JOINTS	500-41
SECTION 600 MISCELLANEOUS CONSTRUCTION	600-1
SECTION 601 STRUCTURAL CONCRETE.....	600-2
SECTION 602 REINFORCING STEEL.....	600-18
SECTION 603 CULVERTS AND SEWERS.....	600-20
SECTION 604 MANHOLES, INLETS, AND METER VAULTS.....	600-23
SECTION 605 SUBSURFACE DRAINS.....	600-25
SECTION 606 GUARDRAIL	600-27
SECTION 607 FENCES	600-29
SECTION 608 SIDEWALKS AND BIKEWAYS.....	600-31
SECTION 609 CURB AND GUTTER	600-34
SECTION 610 MEDIAN COVER MATERIAL	600-36
SECTION 611 CATTLE GUARDS.....	600-37
SECTION 612 DELINEATORS AND REFLECTORS.....	600-38
SECTION 613 LIGHTING.....	600-40
SECTION 614 TRAFFIC CONTROL DEVICES	600-42
SECTION 615 WATER CONTROL DEVICES	600-49

TABLE OF CONTENTS

SECTION 616 SIPHONS	600-50
SECTION 617 RESERVED.....	600-51
SECTION 618 PRESTRESSED CONCRETE	600-52
SECTION 619 WATER LINES.....	600-59
SECTION 620 FIELD FACILITIES	600-60
SECTION 621 RESERVED.....	600-61
SECTION 622 REST AREAS AND BUILDINGS	600-62
SECTION 623 IRRIGATION SYSTEM	600-72
SECTION 624 DRAINAGE PIPE	600-74
SECTION 625 CONSTRUCTION SURVEYING.....	600-75
SECTION 626 MOBILIZATION	600-76
SECTION 627 PAVEMENT MARKING	600-77
SECTION 628 RESERVED.....	600-80
SECTION 629 SURVEY MONUMENTATION	600-81
SECTION 630 CONSTRUCTION ZONE TRAFFIC CONTROL.....	600-82
APPENDIX A. MISCELLANEOUS CONSTRUCTION CONFERENCE AGENDAS.....	A-1
CONFERENCE AGENDAS.....	A-3
PRECONSTRUCTION CONFERENCE NOTIFICATION AND AGENDA.....	A-4
PRECONSTRUCTION CONFERENCE AGENDA	A-8
HOT MIX ASPHALT PRE-PAVING CONFERENCE AGENDA.....	A-9
PRE-DEMOLITION CONFERENCE AGENDA.....	A-33
PRE-ERECTION CONFERENCE AGENDA.....	A-44
STRUCTURAL CONCRETE PRE-POUR CONFERENCE AGENDA	A-55
CONCRETE PAVEMENT PRE-PAVING AND QC/QA CONFERENCE AGENDA	A-68
ENVIRONMENTAL PRECONSTRUCTON CONFERENCE AGENDA AND ATTENDANCE ROSTER.....	A-70
APPENDIX B. EXAMPLE NOTICES, LETTERS, AND FORMS.....	B-1
EXAMPLE LETTERS, NOTICES, AND FORMS.....	B-4
Sample Acceptance Letter	B-5
Sample Buy America Certification	B-6
Sample Summary of Buy America Quantities	B-8
Sample Buy America Certification with Exceptions.....	B-10
Sample Stockpiled Material Letter of Vested Interest.....	B-13

TABLE OF CONTENTS

Sample Prompt Payment Notice.....	B-14
Sample Prompt Payment Law Notice	B-15
Form 7 – Weekly Report on Miscellaneous Pay Items	B-16
Form 10 – Inspector’s Report for Force Account Work.....	B-20
Billing Example: Contractor Bill to CDOT	B-24
Billing Example: Subcontractor Bill to Contractor	B-25
Form 46 – Concrete Truck Mixer Inspection Certification.....	B-26
Form 103 – Project Diary	B-28
Form 105 – Speed Memo.....	B-31
Form 200 – OJT Training Questionnaire	B-34
Form 262 – Weekly Time Count Report – Work Days	B-36
Form 263 – Weekly Time Count Report – Calendar Days.....	B-39
Form 266 – Inspector’s Progress Report.....	B-42
Form 279 – Inspector’s Report of Reinforcing Steel Placed	B-46
Form 280 – EEO and Labor Compliance Verification	B-49
Form 282 – Asphalt Paving Inspector’s Daily Report.....	B-51
Form 568 – CDOT Temporary Speed Limit Reduction	B-54
Form 580 – Equipment Rental Rate Determination Request	B-59
Form 832 – Trainee Status and Evaluation	B-63
Form 838 – OJT Trainee/Apprentice Record	B-66
Form 859 – Project Control Data	B-69
Form 1186 – Contract Funding Increase/Decrease and Approval Letter	B-78
Form 1212 – Final Acceptance Report.....	B-81
Form 1318 – Dispute and Claim Status Report.....	B-84
FHWA Form 1391 – Federal-Aid Highway Construction Contractors Annual EEO Report	B-88
Form 1401 – Block Faced MSE Wall Submittal Checklist.....	B-90
Form 1402 – Panel Faced MSE Wall Submittal Checklist.....	B-92
Piling Form	B-93
Traffic Control Review Form	B-96
Project Final Submittal Checklist.....	B-104
CPM Schedule Review Checklists.....	B-109
APPENDIX C. CHANGE ORDER EXAMPLES	C-1

TABLE OF CONTENTS

CHANGE ORDER EXAMPLES	C-3
APPENDIX D. MISCELLANEOUS DATA	D-1
MISCELLANEOUS DATA	D-3

CDOT CONSTRUCTION MANUAL

SECTION 100 GENERAL PROVISIONS

SECTION 101 GENERAL GUIDELINES

Section 100 presents the general requirements of construction contract administration and includes topics such as the contracting process, the authority of the Department, legal aspects, contract time, and payment for work. The intent and meaning of terms, pronouns, and acronyms that are typically used in Contract documents are found in Section 101. Section 101 also refers to various agencies and organizations whose specifications and construction requirements are referenced in the Contract.

101.1 - 101.100 RESERVED

101.101 SOURCE DOCUMENTS

As needed for clarification and additional information, reference the following documents:

1. CDOT Construction Bulletins,
2. CDOT Cost Data Book,
3. Rental Rate Blue Book for Construction Equipment,
4. CDOT Pavement Design Manual,
5. CDOT Erosion Control and Storm Water Quality Guide and Pocket Book,
6. CDOT Field Materials Manual,
7. CDOT Laboratory Manual of Test Procedures,
8. CDOT M&S Standard Plans,
9. CDOT Policy and Procedural Directives,
10. CDOT Safety Manual,
11. CDOT SiteManager® Users Guide,
12. CDOT Standard Specifications for Road and Bridge Construction,
13. CDOT Standard Special Provisions,
14. CDOT Project Special Provisions,
15. CDOT Supplemental Specifications,
16. CDOT Survey Manual,
17. CDOT Work Zone Safety Book and CDOT MUTCD Supplement, and

18. Contract Plans.

If a discrepancy is found in the Contract documents, check subsection 105.09 of the *Standard Specifications* for the order of precedence to use in resolving the discrepancy.

Note that updates to *CDOT Standard Specifications* are issued quarterly as *Standard Special Provisions*. Updates to the *CDOT Construction Manual* are published periodically in the *CDOT Construction Bulletins*.

101.102 CDOT INTERNET AND INTRANET WEBSITE

Most CDOT information is maintained in an electronic format on the Department's Internet and Intranet website. The Department's website is an invaluable source of information for construction contract administration information. The Department's Internet site is <https://www.codot.gov/> and the Employee Hub site is <https://sites.google.com/state.co.us/cdothub/home>.

Following is a partial list of the electronic information contained on the websites:

Standard Specifications, Standard Special Provisions, M&S Standard Plans, CDOT Construction Manual, and CDOT Construction Bulletins. Contact the Construction Engineering Services Branch for additional information.

101.103 CDOT ORGANIZATION AND STAFF

101.103.1 Chief Engineer

The assignment of complete responsibility for individual contracts to Project Engineers is at the administrative direction of the Chief Engineer, who is responsible for directing all CDOT activities within the Division of Engineering and Maintenance.

101.103.2 Construction Engineering Services Branch Manager

Under the direction of the Chief Engineer, the Construction Engineering Services Branch Manager provides each Region and various Local Agencies with assistance, engineering, and support services for the administration of construction contracts.

Responsibilities include, but are not limited to, the following:

1. establishing consistent policy and uniform standards for the administration of construction contracts;
2. formulating, developing, issuing, and implementing policies, procedures, and specifications to ensure efficient and effective contract administration;
3. providing guidance and training to ensure that policies, procedures, and specifications are clearly understood and uniformly applied;

4. conducting joint FHWA/CDOT Quality Assurance Reviews for construction projects under the Federal-Oversight Program, compiling findings, and providing and implementing recommendations to improve quality in construction; and
5. assisting the Chief Engineer during construction contract dispute/claim resolution.

101.103.3 Region Transportation Director

The Region Transportation Directors exercise overall control of their Regions and act as the Chief Engineer's representatives in their respective Region. Additional assigned duties include supervision of the Region Business Office, EEO Office, Maintenance Section, Planning and Environmental Section, Traffic and Safety Section, and the Program Engineering Section.

101.103.4 Region Program Engineer

The Region Program Engineer reports directly to the Region Transportation Director and directs the operations of the Region Program Engineering Section. The Region Program Engineer is the highest level of authority with design and construction responsibility within the Region. Assisted by Resident Engineers, the Region Program Engineer administers all construction contracts according to the policies and procedures established by the Project Development Services Branch and Construction Engineering Services Branch. The Region Program Engineer is also responsible for funding decisions within the Region.

101.103.5 Resident Engineer

The Resident Engineers within each Region report directly to the Region Program Engineer. They are charged with the overall administration of projects assigned to the unit (i.e., scoping through construction) and for maintaining a unit capable of efficiently and effectively carrying out the Department's policies and procedures, including continuing and special training programs. Resident Engineers delegate authority to Project Engineers based on their experience and ability.

The Resident Engineer is responsible for apprising the Region Program Engineer on the status of work, any problems that are encountered, decisions that have been made, and any recommendations for improvements in construction practices.

101.103.6 Project Engineer

The complete responsibility for the administration and satisfactory completion of a CDOT construction contract is assigned to the Project Engineer. The Project Engineer is the direct representative of the Chief Engineer and reports directly to the Resident Engineer.

The Project Engineer is the first level of authority concerned with unusual circumstances (e.g., non-specification work, work outside the scope of the Contract, disputes, and change orders). As practical, problems concerning contract interpretation should be referred to higher levels of authority until the problem is acceptably resolved. Immediate decisions can be made, and orders written, as necessary, to expedite construction.

Although the Project Engineer has the authority to direct the Contractor's operations, the Project Engineer should refrain from doing so unless special circumstances require such intervention. The Project Engineer is responsible for ensuring that the Contractor uses proper methods for performing quality work safely and in compliance with the Contract requirements. If the Project Engineer or other project personnel attempt to direct the Contractor's operations, the Contractor may claim that the project personnel assumed risk and responsibility for the work product.

101.103.6.1 Consultant Project Engineer

The Project Engineer is the Chief Engineer's duly authorized representative who may be an employee of a consulting engineer (consultant) under contract to CDOT. The Consultant Project Engineer, if not a licensed Professional Engineer, shall be under the responsible charge of the consultant's Professional Engineer (a licensed P.E. in Colorado) who is in direct charge of the work and satisfactory completion of the project. Both the Consultant Project Engineer and the Consultant Professional Engineer shall report directly to a CDOT Resident Engineer (RE), or designee as stated in the scope of services contract.

The responsibilities of the consultant fulfilling the role of the Project Engineer will be similar to that of the CDOT Project Engineer, however, the Consultant Project Engineer and the Consultant Professional Engineer are not authorized to sign or approve Contract Modification Orders (CMOs) and time extensions. The Consultant Project Engineer and the Consultant Professional Engineer shall coordinate as a team to keep the RE informed of project progress as directed and manage the project work. All field revisions and design changes must be approved by the RE prior to implementation.

The Consultant Project Engineer shall not direct the Contractor's operations. The Consultant Project Engineer is responsible for ensuring that the Contractor uses proper methods for performing quality work safely and in compliance with the Contract requirements. If the Consultant Project Engineer or other project personnel attempt to direct the Contractor's operations, the Contractor may claim that the project personnel assumed risk and responsibility for the work product.

When an immediate decision needs to be made regarding the Contractor's work, and that decision may affect project costs or safety of the traveling public or result in a different installation than what is shown on the plans, the Consultant Project Engineer shall contact the CDOT RE for guidance. If the CDOT RE cannot be reached, then the Consultant Project Engineer shall contact the Consultant Professional Engineer to address the issue of the Contractor's work and make sure that all potential safety issues are resolved prior to the Contractor leaving the site for the day. The Consultant Project Engineer shall follow up with the RE as soon as possible to discuss the issue in question.

101.103.7 Project Inspector (Materials Tester)

Under the supervision of the Project Engineer, Project Inspectors are authorized to inspect or test all work performed and materials furnished. Such inspections may extend to all or any part of the work and to the preparation, fabrication, or manufacture of the materials to be used.

Project Inspectors are not authorized to alter or waive provisions of the Contract or to issue instructions.

The Project Inspector shall not direct the Contractor's operations. The Project Inspector shall document and report to the Project Engineer when the Contractor is not performing work safely and in compliance with the Contract requirements. The Project Engineer is responsible for ensuring that the Contractor uses proper methods for performing work safely and in compliance with the Contract requirements. If the Project Engineer or other project personnel attempt to direct the Contractor's operations, the Contractor may claim that the project personnel assumed risk and responsibility for the work product.

The following training is required to perform inspection on a CDOT project:

Technical Series (EPS Assistant I through EPS Technician III) +-6+-6

1. Basic Highway Math
2. Basic Highway Surveying
3. Basic Highway Plan Reading
4. Erosion Control Supervisor

Professional Series (EIT I through EIT III)

1. Basic Highway Surveying
2. Basic Highway Plan Reading
3. Erosion Control Supervisor

The specialty certifications, such as CAPA Asphalt Inspection, WAQTC, and Major Structures, will only be required when an inspector is working on a project where those items of work are performed. For example, a person working on an asphalt overlay would need the pre-requisites plus the CAPA asphalt inspection; a person working on an embankment would need the pre-requisites plus the WAQTC soils; etc. The specialty training requirements apply to the full range of both the technical and professional series listed above.

101.103.8 Staff Bridge Services Branch

101.103.8.1 Quality Assurance Inspectors (Fabrication Inspectors)

Fabrication Inspectors of the Staff Bridge Services Branch act on behalf of the Project Engineer and inspect the Contractor's ability to control quality in fabricated work and materials. The Project Engineer is responsible for notifying the Staff Bridge Fabrication Unit of upcoming bridge work that may require fabrication inspection such as prestress concrete or structural steel bridge elements. The Fabrication Inspectors are authorized to assess and accept or reject the fabricated work, the fabrication plant, and the Contractor's quality control process control inspection and testing personnel. Fabrication Inspectors will contact the Project Engineer

regarding work and materials that are out of specified limits. Fabrication Inspectors also assist field personnel regarding the processing of pre-inspected items and may be contacted at (303) 757-9339.

101.103.8.2 Bridge Construction Assistance

The Staff Bridge Services Branch provides assistance regarding structural items to Region personnel. The Staff Bridge Services Branch processes shop drawings by distributing them to the Project Structural Engineer and returning them to the Project Engineer. Working drawings will also be reviewed as time allows. In cooperation with Project Structural Engineer, Staff Bridge Services Branch provides assistance to field personnel on questions regarding design intent, expertise on operations such as post-tensioning, steel girder bridges, and construction modifications. Structural defects noted during inspection or changes made during construction should be discussed with the Staff Bridge Services Branch. Contact Staff Bridge at (303) 757-9309 for the corresponding Region Unit Leader for bridge construction assistance and questions pertaining to shop drawings.

101.103.8.3 Bridge Construction Reviews

Notify Staff Bridge upon construction completion of every structure that meets the federal definition of a major bridge as well as other structures such as pedestrian and wildlife structures, walls, sign structures, and culverts greater than 4 feet in diameter. A major bridge is any structure that carries vehicular traffic and is over twenty feet long, measured along the centerline of the roadway. In addition to these structures, pedestrian and railroad structures over state highways will be included. Staff Bridge shall conduct a final inspection for acceptance of all structures before project final acceptance is granted. Typically, this is done at the final walkthrough when developing a punch list of items to finish. Coordinate the Staff Bridge final inspection prior to structure contractor demobilization so the Contractor can perform the unfinished work items identified at the inspection without having to remobilize.

Schedule the review by contacting the Staff Bridge PE II assigned to the Region. An additional bridge inspection is required to FHWA/NBIS standards prior to opening to traffic.

101.103.9 ENGINEER IN RESPONSIBLE CHARGE (EIRC)

During the construction phase, every project must have an Engineer in Responsible Charge. A project may require/need more than one EIRC. If you are working on a project and are not an EIRC on the project, then you are working under at least one EIRC. For more information about EIRC refer to CDOT's Construction Engineer in Responsible Charge Information Document which is posted on CDOT's External website at the same location as this manual.

101.104 PROCESS CONTROL/OWNER ACCEPTANCE (PC/OA)

For information on the Quality Assurance Program, see the CDOT Field Materials Manual.

101.105 FHWA INVOLVEMENT

To ensure compliance with applicable engineering, legal, and administrative requirements in the expenditure of Federal funds, the Federal Highway Administration (FHWA) administers the Federal-Aid Program, which funds eligible highway improvements nationwide. Pursuant to the current Federal Transportation legislation (i.e., Moving Ahead for Progress in the 21st Century Act (MAP-21)), CDOT and FHWA have adopted a Stewardship Agreement that defines FHWA oversight requirements on Federal-Aid projects. The Stewardship Agreement specifically addresses the type, scope, and location of projects requiring Federal oversight. An FHWA Operations Engineer assigned from the FHWA Colorado Division Office will be the primary point of contact for Project Engineers. The FHWA Operations Engineer typically will be involved in joint FHWA/CDOT Quality Assurance Reviews and the processing of claims and contract modification orders, as defined in the Stewardship Agreement.

SECTION 102 BIDDING REQUIREMENTS AND CONDITIONS

Section 102 of the Standard Specifications governs the requirements and conditions under which bids may be accepted from contractors. The Construction Engineering Services Branch administers the provisions of Section 102 and may be contacted for assistance with bidding rules and requirements.

102.1 - 102.3 RESERVED

102.4 BID RULES AND CONTRACTOR EVALUATIONS

The Construction Engineering Services Branch Manager is the “promulgator” of the Bid Rules. These rules set the ethical requirements of contractors for bidding and performing CDOT work.

The process for the Project Evaluation System (PES) system is as follows:

1. The Project Engineer will complete an electronic evaluation at the following link:

https://docs.google.com/forms/d/e/1FAIpQLSe78dBQMVY6q8TuZyY2ZiAIR4yH8cqtD2_sYMS-QIpigCdADw/viewform

2. Project Support will send an email to the Project Engineer with two attachments. Attachment 1 will be the evaluation the Project Engineer completed. Attachment 2 will be a form for the Contractor to evaluate CDOT.
3. The Project Engineer will include Attachment 1 in the Finals package submitted to the Finals Administrator.
4. The Project Engineer will forward Attachment 1 and 2 to the Contractor. This serves as the Contractor’s notification of the score, allows for Contractor comments, and provides the Contractor with the form to evaluate CDOT.
5. If the Contractor fills out Attachment 2 and returns it to the Project Engineer, the Project Engineer will forward it to the Construction Area Engineer. The Contractor is not required to evaluate CDOT.

A Finals Administrator will not final a project until the Project Engineer has completed an evaluation and submitted it to the Finals Administrator. Interim evaluations will be performed by the Project Engineer annually if a project lasts longer than one year.

The Project Engineer is not required to provide the Contractor an opportunity to comment on interim evaluations but should provide these interim evaluations to the Contractor if performed.

102.5 EXAMINATION OF PLANS, SPECIFICATIONS, SPECIAL PROVISIONS, AND SITE OF WORK

102.5.1 Project Showings

It is the responsibility of each prospective bidder to examine the site of the proposed work carefully and to schedule an on-site project showing with the Project Engineer listed in the Notice to Bidders

To ensure competitive bidding, the Project Engineer will provide all bidders with an equal opportunity to view the proposed construction site and will conduct each of the project showings in a similar manner. It is important to provide each prospective bidder with identical information. The same Project Engineer should conduct each of the project showings.

To provide equal information to all bidders, the Project Engineer shall share project showing information with all prospective bidders, the appropriate Program Engineer, the appropriate Resident Engineer, the appropriate Construction Services Area Engineer, and the appropriate Estimator. This information shall contain all questions asked by the bidders during the showings and the responses given by the Project Engineer.

The Project Showing form, Form 1389, will be used to document the bidders' questions and the responses from CDOT. As the bidders' questions are answered, they should be emailed to the CDOT representatives listed above. Nonproprietary questions and answers shall be emailed to dot_project_showing@state.co.us. Updated emails will include all questions and answers, not just updates from the previous email.

The final Project Showing Questions and Answers shall be kept as project documentation and be emailed (as stated above) no later than 12:00 noon the Monday before Bid Opening. The Region will answer no bidder questions after the final Project Showing Questions and Answers are emailed. Any major concerns brought up after this time could result in project deferral. The CDOT Award Officer will post the Project Showing Questions and Answers on the CDOT Project Advertisement web page to allow bidders to view the information:

<https://www.codot.gov/business/bidding/future-bidding-opportunities>

Prior to each job showing the Project Engineer shall notify the bidder that the bidder's nonproprietary questions will be documented and made available to all bidders. When a question is asked by a bidder regarding an interpretation of a standard specification, whether it is from the M&S Standard Plans, Standard Specifications for Road and Bridge Construction, or a standard special provision, the response will be to bid the plans.

If the question requires an interpretation of the plans or project special provisions, the CDOT Project Engineer should answer the question or seek guidance from the appropriate sources and respond at a later date. If the Project Engineer's immediate supervisor is unable to answer the question, the next information source would be the appropriate specialty group such as Staff Bridge, Staff Traffic, etc. If the specialty group is unable to answer the question, the Area Engineers should be consulted.

It is CDOT's goal to answer all questions and disseminate all the questions and answers to clarify any areas in the plans and specifications susceptible to misinterpretation wholly and thoroughly. If the questions reveal significant discrepancies in the plans and specifications, a revision should be issued and, if necessary, the project opening delayed.

If the bidder has a question or requests clarification that involves the bidder's innovative or proprietary means and methods, phasing, scheduling, or other aspects of construction of the project, the Project Engineer should direct the bidder to contact the Resident Engineer directly to address the question or clarification. The Resident Engineer will determine if questions are innovative or proprietary in nature. If the Resident Engineer determines that the bidder's question is innovative or proprietary, the bidder's innovative method shall be kept confidential and not shared with other bidders. If the Resident Engineer determines that a question does not warrant confidentiality, the bidder may withdraw the question. If the bidder withdraws the question, the Resident Engineer will not answer the question and the question will not be documented on the CDOT website. If the bidder does not withdraw the question, the question should be answered, and both the question and CDOT answer should be posted on the website.

If it is known that revisions to plans, specifications, or other contractual documents have been, or will be, published and distributed, notify each of the prospective bidders during the project showing. If the Project Engineer volunteers information to a bidder, it will be provided to all the bidders.

The Project Engineer should remind the bidders that the questions and answers document is for information only, and it is the bidder's responsibility to verify the information.

Issuing the question and answer memo and publishing it online will not only help CDOT understand potential risks, but it will help the contracting community understand the risks as well. If both parties understand their risks, the project will be properly bid.

102.5.1.1 Signature Project Showings

Refer to the Project Development Manual for the definition of a Signature Project.

For signature projects, the following procedures should be followed in addition to those detailed in section 102.5.1 above.

All project showings should be completed within the first three weeks after the date of advertisement. Job showings should be attended by the Program Engineer, the Resident Engineer, the Project Engineer, and the Engineering Estimates Program Manager.

The Project Showing form (CDOT Form 1389) should be completed and emailed as soon as the bidder's questions are answered. The final Project Showing Questions and Answers for Signature Projects have the same deadline as specified in section 102.5.1 Project Showings.

Three weeks after the advertisement date, the project staff will review all the questions and comments from the potential bidders and determine if a plan revision or clarification is needed. If a revision or clarification is warranted, the appropriate notification will be sent to all the plan holders on record. If necessary, bid opening may be delayed.

102.6 - 102.10 RESERVED

SECTION 103 AWARD AND EXECUTION OF CONTRACT

Section 103 of the Standard Specifications governs the procedures for determining the successful bidder and entering into the Contract. The Construction Engineering Services Branch administers the requirements of Section 103.

103.1 - 103.4 RESERVED

103.5 SURPLUS FUNDS

When a bid results in surplus funds on the project, the Bids and Awards Unit will issue a Preliminary Financial Statement and will submit a request to the Region Business Office for a budget action.

If the Region wants to retain all or part of the bid surplus, the Region Transportation Director (RTD) shall request retention of surplus funds after bid opening day. The request process for the region has two steps.

Step One

RTD will send an email to the Chief Engineer (CE) with notification of the region's "intent" to request to retain all or part of the bid surplus funds. This email must be submitted to the Chief Engineer by noon the day following bid opening.

Prior to the submission of the email to the CE the region will submit a spreadsheet to the Engineering Estimates and Market Analysis Unit (EEMA) of the Construction Engineering Services Branch analyzing the proposed costs of the work to be added if funding becomes available. The spreadsheet will list all items of work; the unit prices of the low bidder, second low bidder, and third low bidder; and the product extensions for each bidder. If EEMA determines that including the additional work in the low bidder's bid would result in higher costs to CDOT than if it were included in the bids from either the second or the third low bidder, the additional work will not be added to the Contract. The region will also analyze costs to perform the additional work as though it were a separate contract, including additional mobilization, traffic control, indirect costs, etc. This analysis will also be submitted to EEMA in a spreadsheet format containing quantities, estimated unit prices, and product extensions. The EEMA may adjust the estimated unit prices to complete the work under a separate contract as necessary. If EEMA does not concur that the anticipated cost savings to add the work to the Contract is reasonable, EEMA will notify the region.

Step Two

RTD will submit a formal letter requesting to retain all or part of the bid surplus funds to the Chief Engineer's office by the Monday following bid opening.

General Provisions

Both submissions should be sent via email to the Chief Engineer. The second email should contain the funds retention request letter, the first email with initial approval and amount of surplus. The following Units are to be copied on the second email: Office of Financial Management and Budget, Project Budget Unit, Office of Financial Management and Budget - Project Award and Accounting Unit, the Awards Officer in Construction Services, and the Region Business Office Manager.

The formal letter should contain the following justification at a minimum:

Time involved in preparing, letting, awarding, and issuing a notice to proceed for a separate contract.

1. Anticipated competition for the work.
2. Time remaining and the critical work that must be done before winter shutdown period.
3. Justification of work that was omitted because of funding constraints.
4. Environmental clearances for the extra work, if any.

After receipt of the signed letter from the Chief Engineer approving the Region's request to obtain bid surplus funds, the Project Awards and Accounting Unit will add a CMO line in the AASHTOWare® worksheet bid project under category 0200 and item number 70070002. The amount to input in the CMO line will be the net amount of funds retained after allowance for CE and Indirect Costs. The net amount is calculated by dividing the amount retained by the current CE and Indirect rate.

The Project Awards and Accounting Unit will generate a final financial statement and submit it to the Agreements Unit for project award.

SECTION 104 SCOPE OF WORK

Section 104 of the Standard Specifications governs the work under the Contract and specifies procedures for revising the scope of work, if necessary. A revision to the scope of work requires the proper execution of a change order. The Contractor cannot be required to do work beyond the original project limits, unless the Contractor has agreed to complete the work and a project extension change order has been executed. Additional approvals are required for project extension change orders before work can begin. See Section 120.7 for additional information on preparing and processing change orders.

104.1 INTENT OF CONTRACT

The intent of the Contract is to provide for the construction and completion of the work described.

104.2 DIFFERING SITE CONDITIONS, SUSPENSIONS OF WORK, AND SIGNIFICANT CHANGES IN THE CHARACTER OF WORK

Issues relating to differing site conditions, suspension of work, and significant changes in the character of work are usually complex and frequently result in Contractor disputes or claims for additional time and compensation. A change order is required to authorize an adjustment in cost or extension of contract time resulting from the impact of these issues. The expertise of engineering and legal staff outside the office of the Resident Engineer may be useful in assessing the situation. Contact the Area Engineer for additional guidance. See Section 120.7 for additional information on preparing and processing change orders.

104.3 EXTRA WORK

If extra work for which there is no price included in the Contract is necessary or desirable for Contract completion, the Project Engineer may order the extra work to be performed by the Contractor. Extra work must be authorized by a change order and paid for as provided under subsection 109.04 of the Standard Specifications. See Section 109.4 of this Manual for additional information.

104.4 MAINTAINING TRAFFIC

Subsection 104.04 of the Standard Specifications defines the responsibilities for maintaining traffic throughout the project, including items such as detours, access points, and snow removal. The provisions of subsection 104.04 are a day-to-day responsibility of both CDOT and Contractor personnel and will be emphasized during the Preconstruction Conference.

The Contractor must make every reasonable and practical effort to maintain safety and minimize the inconvenience to the traveling public. Project Engineers and Project Inspectors should continually monitor the condition of the traveled way and ensure that the Contractor properly places and maintains traffic control devices in compliance with specified

requirements. Regardless of who is responsible for the cost or repair of maintenance, both CDOT and Contractor personnel must ensure that all dangerous situations are immediately corrected or reported to the Project Engineer or Contractor for correction. See Section 630 of this Manual for additional information on construction zone traffic control.

The Contractor is responsible for the maintenance and repair of all Contract items. Subsection 107.17 of the Standard Specifications permits the Project Engineer to relieve the Contractor of expenses for damage to certain portions of the work caused by traffic or the elements. See Section 107.17 of this Manual for additional information.

104.5 RESERVED

104.6 RESERVED

104.7 VALUE ENGINEERING CHANGE PROPOSALS BY THE CONTRACTOR

Contractors are encouraged to submit Value Engineering Change Proposals (VECPs) to the Department for evaluation. Complete submittal requirements are defined in subsection 104.07 of the Standard Specifications.

The Project Engineer will notify the appropriate Area Engineer upon receipt of a VECP. The following procedure is to be used in the evaluation of VECPs:

1. Determine if a VECP qualifies for consideration and evaluation. The Project Engineer should discuss VECPs with the Resident Engineer and reject any VECP that is incomplete or that requires excessive time or costs for review, evaluation, or investigation. The Project Engineer should also reject proposals that are not consistent with the Department's design or construction policies or criteria for the project, or with the specification. The Project Engineer should notify the Contractor immediately in writing of the rejection, and the reasons for the rejection.
2. Categorize Proposal. Proposals should be categorized as VECP (Category A) or VECP (Category B). See subsection 104.07 of the Standard Specifications for Category definitions.

No VECP can be used to alter incentive and disincentive rates and maximums on A+B (cost plus time) projects. In other words, no additional incentive will be paid resulting from acceptance of a VECP for an A+B project.

For either category of VECP, the Project Engineer should be certain that the estimated quantities, costs, and savings are reasonably accurate. The Contractor shall provide additional information regarding costs or quantities as required by the Project Engineer.

3. Evaluation of the proposal. Upon receipt of a VECP, the Project Engineer will ensure that sufficient time is provided for review and will promptly notify the Contractor if additional time is needed. If additional response time affects the critical path of the

Contractor's schedule, a non-compensable time adjustment to the Contract should be included in the CMO for the accepted VECP (see No. 5 below).

Level of Review (Category A and Category B)

For VECPs (Category A), the Project Engineer will work with the Resident Engineer and Area Engineer to determine an appropriate panel of subject matter experts to evaluate a VECP proposal. The panel may include representatives of Staff Bridge, the Federal Highway Administration (FHWA), the Region Program Engineer, the Area Engineer, and others as necessary. The recommendations of the panel will be provided to the appropriate Region Program Engineer. The Region Program Engineer will then make a final decision in consultation with the Region Transportation Director.

VECPs (Category B) may be evaluated in the Region by a panel consisting of the Project Engineer, Resident Engineer, Program Engineer, and other experts as needed including FHWA. The appropriate Area Engineer should also be included. The Region Program Engineer will then make a final decision, based on the recommendations of the panel.

Review Panel Evaluation

For both Categories of VECPs, the Project Engineer will facilitate the panel's review. All panel members should thoroughly review the VECP specification before beginning evaluation. Evaluation of the VECP should consider the results of any previous Value Engineering (VE) studies conducted on the project during the design phase, structure selection reports, or other decisions, which have been considered previously. Conditions may or may not have changed since these studies and reports were prepared.

VECP Review Panels should consider the potential merits, cost savings, time savings, and original design intent as well as the shared risk of the proposal.

The cost of each individual item in the proposed change as well as the total cost of the proposal should be thoroughly reviewed. The recommendations of the panel will be provided to the Program Engineer for a decision.

When the Program Engineer issues a decision, the Project Engineer will notify the Contractor in writing, of the approval of the VECP or the reasons for rejection.

4. Contractor Appeal Process. Appeals can only be made on VECPs (Category A). The Prime Contractor submitting the VECP may file a one-time appeal of a denial through the Project Engineer to the Region Transportation Director. The Contractor must provide a valid reason for the appeal, and the decision of the Region Transportation Director will be final.
5. Processing of accepted VECPs. After the terms of the proposal are agreed upon, the Project Engineer will process the proposal using Form 90 - Contract Modification Order. See Appendix C for an example.

It is preferable that the final cost be agreed upon before implementation. However, based on the estimated value of the change, the Project Engineer and the Contractor may agree to a

flexible method of determining the final cost share. Such agreements must be documented in detail on Form 90.

The Form 90 should identify the difference between the original planned quantities and the quantities represented by the accepted VECP. The net savings shall be calculated pursuant to the formula shown in the specification.

If a VECP saves time on the project, especially on A+B projects, the contract time will be adjusted accordingly as noted in the examples below:

Example 1: - If an A+B project initially has a contract time of 300 calendar days, and CDOT accepts a VECP that saves the project 20 days, the CMO will reset the contract time to 280 days. The allowable incentive and disincentive rates and maximums will be unchanged.

Example 2: - An A+B project initially has a contract time of 200 calendar days with an early completion incentive of \$10,000 per day. A VECP proposes to save 10 days, but at an increased construction cost of \$85,000. The early completion incentive cannot be used to offset the additional construction costs, and CDOT would not accept the proposal because it would result in additional construction costs.

The Contractor's development and re-design costs and CDOT's review costs are those costs over and above what each party would have expended if the VECP did not exist. If the Contractor's development and re-design costs include the services of a Consultant Engineer, they must be documented with certified billings. CDOT's costs should include costs for reviews by Staff Bridge, Region or Headquarters personnel, and Consultants, prompted by the VECP. The rates for CDOT's review services are listed in the specification.

The Contractor will be paid for the work represented by the appropriate pay items as the work progresses and is acceptably performed. In addition, the VECP Incentive will be paid to the Contractor upon acceptable completion of all the construction work represented by the VECP, according to the formulae in the specification via the SiteManager® System. To initiate payment, the Project Engineer must enter a 900-item "Value Engineering Change Proposal Incentive" into SiteManager®.

If an analysis of the schedule, modified to include the VECP, shows an impact to the critical path, consideration should be given to adjusting the contract time using the CMO. The CMO letter of explanation should describe impacts to the project schedule. The CMO letter of explanation should also describe impacts to the original scope of the project, including but not limited to milestones or lane rentals. The CMO should address adjustments to these items if warranted.

SECTION 105 CONTROL OF WORK

The authority, rights, and duties of CDOT and the Contractor are specified in Section 105 of the Standard Specifications. Pay particular attention to the requirements of Standard Special Provisions that pertain to Process Control/Quality Assurance and roadway smoothness.

105.1 AUTHORITY OF THE ENGINEER

The Engineer will decide all questions regarding the quality and acceptability of work, material, and rate of progress; all interpretations of the Contract documents; and the acceptable fulfillment of the Contract.

105.1.1 Project First Program

Project First is CDOT's partnering program. The Project First website (<https://www.codot.gov/business/designsupport/design-docs/project-first-on-construction-projects>) includes the information and tools needed to implement the Program. The Issue Documentation Matrix (or The Risk Register) and Escalation Ladder on this website will be completed by the Project Engineer and the Contractor to suit the project's needs.

Project First is a high priority for CDOT. CDOT's region management, HQ management, and Construction Area Engineers will assist in and monitor its use and success. For this to happen, the Project Engineer will place the newly developed Issue Documentation from the Initial Workshop in a Google Shared Drive. Contact your Area Engineer for access to this drive. When the Matrix is updated as future workshops occur and issues are addressed, replace the older version in the Google Shared Drive. The title of the document will include the subaccount code and the month and year of the workshop. (Example of title - 12345_12_2018)

105.2 PLANS, SHOP DRAWINGS, WORKING DRAWINGS, OTHER SUBMITTALS, AND CONSTRUCTION DRAWINGS

Shop drawings are submitted to the Project Engineer for formal review and returned to the Contractor for action. Working drawings are submitted to the Project Engineer for information only and are not formally reviewed or returned to the Contractor. Table 105-1 of the Standard Specifications defines which items require shop drawings and working drawings. Review all Contract Plans and Specifications with respect to Contractor submittal requirements.

105.2.1 Working Drawing Review

The Project Engineer may review the working drawings for conformity to Contract requirements; acceptance of the work will be based on the Contract requirements. For archival purposes, the Project Engineer will forward one set of working drawings to Bridge Records, in care of Staff Bridge, for the following structural items:

1. expansion devices (0 inch to 4 inch),

2. precast panel deck forms,
3. permanent steel bridge deck forms, and
4. bridge railing.

105.2.2 False work Certification

The Contractor's Professional Engineer shall determine when false work drawings are required.

In accordance with subsection 601.11(b) of the Standard Specifications, the Contractor's Engineer will provide the required certifications before the placement of any concrete that will be supported by false work.

See Section 601.2 of this Manual for additional information on false work.

105.2.3 Shop Drawing Review Process

The Project Engineer will use the services of the Staff Bridge Services Branch to process shop drawings. The shop drawing submittal usually goes through the following steps:

1. Unless otherwise specified, the Contractor shall submit electronic shop drawings to the Project Engineer. Shop drawings shall be stamped "Approved for Construction" and signed by the Contractor before CDOT's review.

Subcontractors and suppliers shall submit shop drawings to the Contractor who shall approve the drawings for construction, which then shall be submitted to the Project Engineer.

2. The Project Engineer will retain one copy for informational purposes and transmit another copy to the Project Structural Engineer. The Project Engineer will discard the retained set when the reviewed shop drawings are returned. The Project Engineer and Project Structural Engineer will document the time the shop drawings are received.
3. The Project Structural Engineer will review and mark each page of the shop drawings "Reviewed, no exception taken", "Reviewed, revise as noted", "Resubmit, revise as noted", as appropriate. The Project Structural Engineer will retain one copy and return another copy to Bridge Records.
4. The Project Engineer will retain one copy of reviewed shop drawings for the project records in ProjectWise and send one copy to the Contractor (who will provide one copy to the supplier) and one copy to each railroad company, as applicable.

If marked "Resubmit," the Contractor/supplier will make the appropriate corrections, and the above procedures will be repeated upon receipt of the corrected drawings.

105.2.4 Construction Drawings

The Project Engineer shall retain one set of plans, reviewed shop drawings, working drawings, and other submittals and mark on this set all changes and deviations as the work progresses.

Upon completion of the work, these drawings will be used in preparing As-Constructed Plans (see Section 121.2.3). The Contractor is no longer contractually required to keep a set of all changes and deviations.

105.3 CONFORMITY TO THE CONTRACT

Subsection 105.03 of the Standard Specifications requires the Contractor to perform work in conformity with the various Contract provisions. Although criteria for determining acceptability of the work is defined, good engineering judgment must be used to determine conformity with the intent of the Contract.

105.3.1 Use of Price Reductions and Warranties

The Contractor is required to furnish materials and workmanship that conform to the requirements of the Contract. However, there are rare, brief, and accidental instances during the project where the Contractor could produce material or work that is slightly out of tolerance. In such cases, price reductions will be used.

Price reductions are not to be used as a general method of continually accepting nonconforming items on the project, nor are they to be used for items under the provisions of the Process Control/Quality Assurance Specifications (see Section 105.3.2). Where nonconformance is detected, the Project Engineer will immediately require the Contractor to bring the item back into conformance. If the Contractor does not comply, the Project Engineer will issue a written stop work order for the item until the problem is satisfactorily corrected.

It is not acceptable to accept a warranty of any kind in lieu of the Contractor providing specification material. If the Original contract did not include a warranty provision, do not add a warranty provision after project award.

105.3.2 Price Reductions for Nonconforming Materials

Although materials will be sampled and tested in accordance with the schedules and procedures presented in the CDOT Field Materials Manual, CDOT has the right to test materials at any time during the project. Any material that appears suspect during the course of the work should be immediately sampled and tested, regardless of specified sampling schedules, and treated as a one sample lot.

105.3.3 Price Reductions for Nonconforming Work

Nonconforming work is work that does not conform to the requirements of the Contract. The Department classifies nonconforming work as follows:

1. nonconforming work that is reasonably acceptable, and
2. nonconforming work that is unacceptable.

The final determination of how to classify nonconforming work, as defined in the Standard Specifications, is the responsibility of the Project Engineer. See Section 105.3.3.1 and Section

105.3.3.2 of this Manual, respectively, for the processing procedures for reasonably acceptable and unacceptable work.

105.3.3.1 Reasonably Acceptable Work

Reasonably acceptable work is work that does not conform to the Contract but is reasonably acceptable and may remain in place, as assessed by the Project Engineer.

There are two processing procedures to consider, depending on whether the work item has an associated “F” factor. See Section 105.3.3.1.1 for processing guidance on Contract items without an “F” factor and Section 105.3.3.1.2 for guidance on items with an “F” factor.

105.3.3.1.1 Contract Items without “F” Factors

For Contract items that do not have an element listed in the Table of Price Reduction Factors in the Standard Specifications or Special Provisions, the price reduction should be based on engineering judgment. Such reductions must be documented by a change order. When assessing a fair and equitable price reduction for accepting nonconforming work of this type, the impacts on the item’s service life and future maintenance costs must be considered. The Project Engineer should contact the Region Materials Engineer and as needed, the Materials and Geotechnical Services Branch for assistance with this determination.

105.3.3.1.2 Contract Items with “F” Factors

For Contract items that have an element listed in the Table of Price Reduction Factors in the Standard Specifications or Standard Special Provisions, determine the price reduction based on the equation and methodology provided in the Contract. The equation is based on statistical sampling and testing data. The procedures for establishing sampling lots and performing random sampling and testing are presented in the CDOT Field Materials Manual. These procedures must be followed. Use the following guidelines when determining price reductions for Contract items with “F” factors:

1. **Sampling and Testing Errors.** Results from erroneous samples and tests will not be used. The reason for voiding samples and tests will be noted on Form 626 - Field Lab Test Results, which must be signed by the Project Materials Tester.
2. **Calculations.** Calculations will be performed using the current version of the computer price reduction program available from the Pavement Management and Design Program of the Materials and Geotechnical Services Branch. Input data should be carefully checked to ensure accuracy before running the program.
3. **Outliers.** Certain test results may be statistical outliers. An outlier does not imply an incorrect result, rather a result that is not acceptable for use in determining price reductions (i.e., outside statistical limits). Outliers should be promptly investigated for errors and the material retested if an error is discovered. The new result, if found statistically acceptable, should be used in determining the price reduction.
4. **Total “P” Value.** Use the total “P” value to assess the work as follows, where “P” is the price reduction percentage factor:

105.3.3.2 Unacceptable Work

Unacceptable work is work that is not in conformance with Contract requirements and of such poor quality that the final product is unacceptable. The Project Engineer will require the unacceptable item to be removed, replaced, or otherwise corrected to bring the item into conformance. Such activities by the Contractor will be at no additional cost to the Department.

105.3.4 Process Control/Quality Assurance (PC/OA) Specifications

105.3.4.1 Cooperation and Communication

Communication between project personnel is essential to implementing PC/OA specifications and resolving project issues. The Project Engineer, the Contractor's Superintendent and Process Control Supervisor, as well as other project personnel, generally achieve this goal by attending formal or informal weekly meetings. Note: there may be project specific provisions, which require weekly meetings to coordinate schedules and address material quality and traffic control issues.

105.3.4.2 Quality Level

Contract items that are governed by PC/OA specifications require random sampling and testing during the prosecution of the work. Results of such tests are statistically analyzed to determine Quality Level (i.e., the percentage of work projected to be within specified requirements). Depending on the Quality Level, a factor will be assigned to adjust payment for the work as discussed in Section 105.3.4.3.

The Plan Value in the Concrete 03 program is not labeled correctly. It should be labeled as the Lower specification limit (TL). The calculations used in Colorado Procedure 71 for the Lower Quality Index are based on this value. This (TL) is also defined in Subsection 105.06 as the Lower Tolerance Limit. When submitting the final report, strike out the words Plan Value and replace them with Lower Specification Limit or Lower Tolerance Limit as shown in Figure 100 - 1. Do not adjust the default value of 570 psi when assigning the Plan Value in the Concrete 03 program.

EXAMPLE CONCRETE 03 PRINT OUT

```

Department of Transportation          Project No: Example
State of Colorado                  Project Code: 12345
June 23, 2015                      Region No: 4
Quality of PCCP (Alt Str), 03-11-04 Location: Greeley
Concrete03, v4.0.1.501(913072210) Supplier:

*** PARTIAL REPORT ***

Flexural Strength - Process 1
-----
Spec. No: 12345                    Plan Value: 570 psi (TL)
Criteria: Flexural Strength        Place Price: 35.00
Class: P(Pavement)                Furnish Price: 0.00
Item: 412-00800(PCCP 8 inch)      Unit Price: 35.00

Comments: Example
-----
Process Test      Date      Date      Test      Total
No.   No.   Placed   Tested   Quantity Quantity Value   MQL

Flexural Strength - Process 1 Summary
(no tests)
    
```

Lower Spec. Limit
Lower Tolerance Limit

EXAMPLE CONCRETE 03 PRINT OUT
Figure 100 - 1

Figure 100 - 1

105.3.4.3 Incentive/Disincentive Payments

PC/OA specifications define an incentive for the Contractor to provide a high-quality Contract item and a disincentive for producing a product with lesser quality. A pay factor, based on Quality Level, is used to adjust payment. See Section 105.3.4.2 for information on Quality Level. Pay factors can be categorized as follows:

1. Pay Factor ≥ 1.0000 . A pay factor greater than or equal to 1.0000 will be used for work and materials with a Quality Level of a high-quality product (i.e., the better the quality, the greater the payment above the unit bid price).
2. Pay Factor < 1.0000 . A pay factor less than 1.0000 will be used for work and materials with a Quality Level representing a lesser quality product (i.e., the poorer the quality, the greater the reduction in pay below the unit bid price).

Incentive payments compensate the Contractor for maintaining good process control that will produce high-quality material. High-quality materials will increase the performance and service life of the final product. The Contractor must maintain a consistent quality to earn incentive payments. Disincentive payments are applied when the Contractor has poor process control that will produce an inferior product.

105.3.4.4 Acceptance Sampling

To ensure statistical accuracy, acceptance samples for PC/OA specifications must be obtained through a stratified random sampling procedure. The random samples will be used to statistically analyze the acceptance of the work. The following example illustrates the stratified random sampling procedure:

1. Given: Testing Frequency. The testing frequency in this example is one test for every 500 tons. Therefore, a random sample will be taken from every 500 tons.
2. Select Random Location. To determine the exact location for the density test, randomly select both a longitudinal station and a transverse offset.
3. Obtain Sample. Perform the density test at the exact location of the randomly selected longitudinal station and transverse offset.

Although acceptance sampling is performed to meet PC/OA specifications, additional sampling and testing may be performed at the discretion of the Project Engineer, such as where a material appears obviously deficient. Such samples and tests are not random and, therefore, must not be incorporated in the PC/OA statistical analysis. Consider the following examples for a project that includes a PC/OA specification for hot mix asphalt (HMA):

Example 1 - Segregation. Quality Assurance tests for aggregate gradation are being taken from the cold feed at the plant. The test results are within specified requirements; however, the Project Engineer notices an obviously segregated area behind the paver screed and immediately requests the Contractor to stop the paver, remove the segregated area, and replace the deficient material with non-segregated HMA. If the Project Engineer and the Contractor disagree on the material being segregated, the Project Engineer will have the material sampled and tested in accordance with the specifications. The Project Engineer will not allow the Contractor to place segregated material.

Example 2 - Asphalt Content. Quality Assurance tests for asphalt content are being performed at the plant, and the test results are within specified limits. The Project Engineer suspects that a truckload of HMA contains too much asphalt cement. The Project Engineer immediately requests the Contractor to obtain a sample of the HMA material. If the test results are outside specified limits and the Project Engineer determines that the material is unacceptable, the Contractor must remove and replace the material at no cost to the project.

CDOT may sample materials at any time and location, especially if the Project Engineer suspects that there is an obvious defect. The material represented by that sample will be accepted or rejected based on the test results of the sample. Samples that are not randomly selected will be individually tested, and the test results and the quantity they represent will not be included in the PC/OA statistical analysis.

105.4 - 105.6

105.7 CONFORMITY TO ROADWAY SMOOTHNESS CRITERIA

Interpreting the Pavement Smoothness Specification and Profiler Operating Parameters

Asphalt Pavement Smoothness Category Changes

There are some cases when asphalt smoothness categories on projects could be changed. Project HRI (Half-car Roughness Index) Category changes can only be executed by a change order by the CDOT project manager/engineer.

Some category changes can take place if a project has varying curb and gutter layout, varying pavement obstructions, short lead-ins to intersections, curves that cannot be traveled at least 15 MPH in a high-speed profiler, or short sections at a bridge.

For pavement smoothness categorization instructions see Design Bulletin 2011-3. The link for the design bulletin website is listed below.

http://www.coloradodot.info/business/designsupport/bulletins_manuals/design-bulletins/current

All smoothness category changes shall be made prior to any construction activity.

Some examples of situations where smoothness categories could be changed are:

Example 1: A project has a 6-lane divided highway with curb and gutter on each side along with a number of manholes and utility boxes and/or intersections with grade breaks. However, the project's middle lane is relatively free from any obstructions. This project could have HRI Category IV assigned on the two outside lanes in each direction and HRI Category I or II in the middle lanes. If the initial project category was all Category I or II, then a change could be made.

Example 2: A project has a low volume road that is receiving a single thin asphalt overlay (less than 1.5 inches). It was initially assigned HRI Cat I, II or III but because it is a single thin lift it should have been HRI Category IV. This could be a case where a change could be made.

Example 3: A project has a very short lead-in to an intersection and the project was assigned HRI Category I or II. Because there is not a lot of lead-in, it could be a good idea to change this project to a Category IV or remove the incentive/disincentive and apply the localized roughness criteria only for the assigned smoothness category.

Example 4: A project has a short pavement section on each side of a bridge and was originally assigned as Category I or II. Because there is only a short section of pavement, it could be a good idea to change this project to a Category IV or remove the incentive/disincentive and apply the localized roughness criteria only for the assigned smoothness category.

Example 5: A project has a section of pavement with a tight curve where a vehicle must slow down to below 15 MPH. This section of the pavement will be excluded from incentive/disincentive payments and localized roughness and shall be tested with a 10-foot straight edge.

Example 6: A project is a total of 3 miles. Two miles of the project have no curb and gutter. One mile of the project has curb and gutter and a large number of manholes. This project should receive two different smoothness categories for the two sections of the project.

Exclusions

Smoothness specifications are in subsection 105.07 and 105.08 for asphalt and concrete pavements respectively. Pavement smoothness incentive/disincentive payments are excluded in some areas.

Shoulders with a width less than 12 feet are not subject to incentive and disincentive payments or localized roughness, but shoulders with a width greater than 12 feet are to be profiled and evaluated for localized roughness. Some of these wide shoulders will be future driving lanes and will also be evaluated for incentive/disincentive.

When a project contains a roundabout, the roundabout is excluded from incentive/disincentive payments. A roundabout is a turning lane and will be evaluated for localized roughness only if the profiler can maintain a speed of over 15 MPH.

If there is not enough of a lead-in for the profiler to get up to speed to profile a bridge. This is either because of a sharp curve before it or the extent of the project does not allow it, the short lead-in is excluded.

Areas that cannot be tested with a high-speed profiler (HSP) and exclusions shall be tested with a 10-foot straight edge.

Conditions for Profiling

Some conditions do not allow the profiler to collect data in an accurate or safe fashion. Some of those conditions are:

If the ambient temperature is less than 34 degrees Fahrenheit, the profiler cannot be operated because the electronics are outside of their operating parameters. If the surface of the pavement is wet, or has some type of shining membrane, the profile data will be compromised and cannot be performed. Examples of a shining membrane include fresh tack coats, magnesium chloride, and some SMA (Stone Matrix Asphalt) pavement. Traffic should be allowed to travel in these areas to remove the sheen.

When scheduling profiling, it is important to make sure that there are no other construction activities taking place on the finished pavement. These activities include shouldering and guardrail installation. The area to profile should be free from debris and all construction activities at the time of the profile. Debris will increase the roughness results and penalize the

contractor. Construction activity can cause interruptions in profiling requiring additional time to properly profile. This can increase the project's traffic control cost.

The distance calibration site is required to be 1056 feet long with a lead-in and lead-out. The lead-in/out shall be long enough to allow the profiler to get up to testing speed and safely stop. The distance calibration site shall be in an area with a speed limit at least as fast as the testing speed. For example, do not have a distance calibration site on a local road when results are needed on the interstate.

Submission of Pavement Smoothness Data

Data collected by the contractor shall be submitted to the Concrete & Physical Properties Unit immediately. The data can be submitted electronically through the CDOT network, the CDOT FTP server, ProjectWise, or email.

Contact the Concrete and Physical Properties Unit at 303-398-6549 to determine the best method for data submittal. Submitting the smoothness data promptly will allow CDOT to verify the contractor's test results if needed and allow prompt payment for incentive/disincentives. The specification requires that smoothness test results be returned to the contractor within 10 calendar days after data collection.

Prior to accepting data from the contractor, verify that the equipment and operator are currently certified. Data collected by uncertified operators or equipment is invalid and will need to be recollected. If a project contains two significantly different speed limits, the project could be done in two different profiles.

Corrective Action Requirements

All CDOT projects require an initial profile to be completed, evaluated by CDOT, and corrective work to be completed. All corrective work must be completed, and each lane must be profiled and evaluated again. If a project's initial profile does not contain any corrective action areas, a second profile is not required unless additional grinding is done for disincentive reduction or elimination.

Localized roughness is based on the HSP data only. If necessary, a second profile can be requested. For example, localized roughness is not based on feel.

The localized roughness report does not designate grind areas. It only designates areas in the pavement where roughness exceeds the threshold. A plan shall be established to correct the out of spec areas. Localized roughness corrective work may be required even when tenth mile section corrective work is not required.

If additional help is needed, please contact your Regional Materials Engineer or the Concrete and Physical Properties Unit at 303-398-6549.

105.8 RESERVED

105.9 COORDINATION OF PLANS, SPECIFICATIONS, SUPPLEMENTAL SPECIFICATIONS, AND SPECIAL PROVISIONS

Subsection 105.09 of the Standard Specifications states that the Contract Plans, Standard Specifications, Supplemental Specifications, and Special Provisions are essential parts of the Contract and are intended to be complimentary. If a discrepancy is found in these documents, the discrepancy should be resolved based on the order of preference presented in subsection 105.09 of the Standard Specifications.

105.10 COOPERATION BY CONTRACTOR

The Contractor is required to have a competent Superintendent, authorized to act on behalf of the Contractor, who will be on the project at all times. The Contractor Superintendent must be on the project when subcontractors are working, even if the Contractor is not performing work with its own forces. A Superintendent who is not competent should be removed from the project. The Superintendent is responsible for all subcontractors and suppliers and must schedule and control their respective operations.

105.11 COOPERATION WITH UTILITIES

CDOT will attempt to have all utility adjustments coordinated as soon as practical and the Contractor is expected to cooperate fully with the affected companies. No additional compensation will be allowed by the Department for any delay or damage to, associated with, or caused by utility appurtenances or adjustments that are shown in the Contract.

The Contractor must consider all delays noted in the Contract when submitting the bid. If the utility installation takes longer than anticipated, it may qualify as a changed condition under subsection 104.02 of the Standard Specifications. Unforeseen utilities or unplanned relocations should also be handled as a changed condition. If such a situation develops, it is imperative that good records be maintained. The project records must document the events leading to the situation and the effect of the delay on the Contractor's operations. Nonetheless, the Project Engineer should encourage the utility company to expedite its work and coordinate with the Contractor to minimize the impact on the overall project schedule.

105.12 COOPERATION BETWEEN CONTRACTORS

Subsection 105.12 of the Standard Specifications requires the Contractor to prosecute the work required by the Contract without interfering with other contractors.

105.13 CONSTRUCTION STAKES, LINES, AND GRADES

Subsection 105.13 of the Standard Specifications prohibits the Contractor from beginning construction work until adequate lines and grades have been established. A Pre-survey

Conference will be held before the survey is performed (see Section 120.13.6). If the survey work is subcontracted, the subcontractor must first be approved using Form 205 - Sublet Permit Application. Before construction, the Project Engineer should ensure that the construction stakes have been located in accordance with Section 625 of the Standard Specifications.

105.14 AUTHORITY AND DUTIES OF THE PROJECT ENGINEER

105.14.1 Authority of Project Engineers

The Project Engineer has immediate charge of the administrative and engineering details of the Contract and has the authority to exercise all duties and responsibilities of the Engineer, as referenced in the Contract, except those specifically retained by the Chief Engineer. The Project Engineer, as the Chief Engineer's representative, is authorized to sign change orders and is responsible for decisions on Contractor claims for additional compensation and extension of contract time that are filed pursuant to subsection 105.22 of the Standard Specifications. Note that only CDOT Project Engineers (not consultant or other), by law, can obligate funds or authorize payments on CDOT Contracts.

105.14.2 Duties of the Project Engineer

Specific responsibilities include construction of the project in accordance with the plans; enforcement of governing specifications and special provisions; control of inspection; proper documentation; and preparation of change orders. By law, consultant or entity Project Engineers perform the same functions as CDOT Project Engineers but cannot obligate funds or authorize payment on behalf of CDOT. As the Department's representative, the Project Engineer has frequent personal contacts with the Contractor, property owners, municipal officials, utilities, and the traveling public; thus, personal conduct should be a credit to both the individual and CDOT.

The Project Engineer's duties regarding construction Contracts include:

1. Administer the Contract according to established CDOT Policies and Procedures, including those described in this manual.
2. Ensure that all Work and Materials used on the Project, and applicable Project documentation conform to Contract requirements and established CDOT Policies and practices. Document and bring to the attention of the Resident Engineer items that do not meet the Contract or accepted CDOT guidelines.

The Contractor shall make all requests in writing and the Project Engineer shall respond to those requests as directed by the RE. Responses to Contractor requests shall be in writing on a CDOT Form 105 and shall be documented in the daily diary. Instructions and directions provided to the Contractor shall be documented on a CDOT Form 105 and in the daily diary.

3. Manage the Project within the current approved construction budget authorization, or approved budget changes.

General Provisions

4. Ensure Contract Time is managed in a way that benefits the Project.
5. Ensure timely completion of the Project based on the original project schedule and approved schedule revisions.
6. Ensure the Work is inspected daily and as required to ensure reasonable conformance to the Contract.
7. Ensure the Project records and other documentation are proper and current.
8. Ensure DBE, OJT, and other requirements are fulfilled.
9. Ensure the Contractor is paid timely for all Contract items that are satisfactorily completed in accordance with the Contract.

The Consultant Project Engineer's duties regarding construction Contracts include:

1. Administer the Contract according to established CDOT Policies and Procedures, including those described in this manual.
2. Ensure that all Work and Materials used on the Project, and applicable Project documentation conform to Contract requirements and established CDOT Policies and practices. Prior to the work taking place the Consultant Project Engineer and Consultant Professional Engineer shall obtain written approval from the RE or CDOT Engineer of Record for:
 3. All price adjustments.
 4. Documentation that does not meet the Contract or accepted CDOT guidelines.

The Contractor shall make all requests in writing and the Consultant Project Engineer shall respond to those requests as directed by the RE. Responses to Contractor requests shall be in writing on a CDOT Form 105 and shall be documented in the daily diary. Instructions and directions provided to the Contractor shall be documented on a CDOT Form 105 and in the daily diary.

5. Manage the Project within the current approved construction budget authorization, or approved budget changes.
6. Ensure Contract Time is managed in in a way that benefits the Project.
7. Ensure timely completion of the Project based on the original project schedule and approved schedule revisions.
8. Ensure the Work is inspected daily and as required to ensure reasonable conformance to the Contract.
9. Ensure the Project records and other documentation are proper and current.
10. Ensure DBE, OJT, and other requirements are fulfilled.

11. Ensure the Contractor is paid timely for all Contract items that are satisfactorily completed in accordance with the Contract.

105.14.3 Problem Resolution

The Project Engineer should attempt to resolve quality concerns with the Contractor Superintendent. If the concern is not resolved, the Project Engineer should discuss the concern with the Resident Engineer and consider suspending work on the affected item. Additional guidance may be obtained from the Region Materials Engineer, Region Program Engineer, Materials and Geotechnical Services Branch, and Area Engineer. Address problems immediately. Do not wait until a substantial portion of the item is completed before resolving the problem or seeking advice. If work is suspended, do not permit work to resume until the problem has been corrected.

105.14.4 Quality of Workmanship

The Project Engineer must continually assess the quality of workmanship. The traveling public perceives quality primarily in terms of roadway durability, rideability, and appearance. It is therefore essential that the Project Engineer assertively and effectively partners with the Contractor and administers the Contract to encourage overall quality improvements.

The following example illustrates the impact of poor workmanship: The Contractor used high quality, high-performance HMA material and excellent laydown and compaction procedures. In addition, the Contractor was extremely quality conscious and received the maximum quality incentive payment. However, the Region received several complaints from the public regarding crooked pavement markings, spilled pavement-marking paint, and splashed asphalt emulsion on curbs and median barriers, and unsightly and uneven guardrail. In addition, complaints were received regarding a rough riding surface. Upon investigation, the Contractor had apparently dumped shouldering material on the surface and bladed it off with a grader. The grader had damaged the new pavement surface and created a dangerously low shoulder. Although material and density met specified requirements, the overall quality of workmanship with respect to appearance and rideability was highly unacceptable.

105.14.5 Assessing Acceptability of Work

In assessing quality and acceptability, consider the following questions during construction:

1. Will CDOT customers (i.e., Colorado taxpayers, traveling public) be satisfied?
2. Would I accept this work if I owned the facility?
3. Would I pay for this work out of my own pocket?

If any of these questions have a negative response, the Project Engineer should immediately resolve the problem as discussed in Section 105.14.3.

105.15 DUTIES OF THE PROJECT INSPECTOR

CDOT Project Inspectors are authorized to inspect all work and materials furnished by the Contractor. Such inspections may extend to all or any part of the work and to the preparation, fabrication, and manufacture of materials to be incorporated in the work. Project Inspectors are not authorized to alter, waive, or issue instructions contrary to the provisions of the Contract nor act on behalf of the Contractor, such as a foreman.

105.16 INSPECTION AND TESTING OF WORK

The Project Engineer is the direct representative of the Chief Engineer in all matters related to the Contract. Project Inspectors and Material Testers are directly responsible to the Project Engineer.

Project Inspectors and Material Testers should consider the following:

1. **Safety Considerations.** Review the CDOT Safety Manual and the Contractor's Safety Policy to ensure that all inspection activities will be in compliance. Do not take unreasonable risks when performing your duties. Report any unsafe practices immediately to the Project Engineer.
2. **Authority and Responsibilities.** Discuss your authority and responsibility with the Project Engineer who has day-to-day project responsibility. Know your responsibilities and authority before construction begins.
3. **Contract Documents.** Become thoroughly familiar with the Contract documents (e.g., Contract Plans, Standard Specifications, and Special Provisions). Become familiar with available reference materials and understand their applicability.
4. **Sampling and Testing.** Review sampling and testing requirements and the certifications that must accompany materials upon delivery. See the CDOT Field Materials Manual for additional information.
5. **Documentation.** Review the format and required content for pay documentation, CDOT forms, and daily inspection diaries.
6. **Maintenance of Traffic.** Where traffic is maintained during construction, review the approved Method of Handling Traffic and the required type, number, and arrangement of traffic control devices.

105.17 **Changes.** Advise the Project Engineer of any changes, corrections, delays, rejections, or deviations from the Contract Plans and Specifications. **REMOVAL OF UNACCEPTABLE WORK AND UNAUTHORIZED WORK**

Work that does not conform to specified requirements will be removed and replaced in an acceptable manner at the Contractor's expense. The project records will contain written documentation of the reason for the removal and replacement.

105.18 LOAD RESTRICTIONS

During construction, the Contractor's haul trucks and construction equipment must conform to the load restrictions and vehicle dimensions shown in Appendix D and <https://sites.google.com/state.co.us/cotriporgfreight/helpful-information/legal-weights-dimensions>. These restrictions apply to all Colorado public roads and bridges. Project personnel must continually monitor compliance with subsection 105.18 of the Standard Specifications. In general, project personnel must not allow overweight construction vehicles to traverse Colorado roads and bridges. Overweight vehicles shall not be permitted on newly constructed bridges or pavement or on other pavement or existing elements of the project that will not be removed and replaced. Weight limits apply to bridges and pavements as soon as they are constructed. Occasionally, however, the Contractor will need to move extremely heavy equipment, such as a large crane, across a bridge or culvert. In such cases, contact the Staff Bridge Services Branch for guidance before the equipment is moved.

105.19 MAINTENANCE DURING CONSTRUCTION

Subsection 105.19 of the Standard Specifications governs the Contractor's responsibilities for maintenance during construction, which must be continuous and effective. The Contractor will be held responsible for the maintenance and repair of all Contract items, except as noted in Section 107.17. CDOT project personnel should monitor and require correction of any condition that threatens or inconveniences the traveling public (see Section 104.4).

105.20 FAILURE TO MAINTAIN ROADWAY OR STRUCTURE

If the Project Engineer notifies the Contractor of a maintenance problem and the Contractor does not take action, subsection 105.20 of the Standard Specifications allows the Project Engineer to have the problem fixed and deducted from the money due the Contractor. See Section 107.17 of this Manual for additional information.

105.21 ACCEPTANCE

105.21.1 Partial Acceptance

The partial acceptance of a specific phase will be allowed if included in the original Contract. Partial acceptance for other occurrences must be in accordance with subsections 105.21, 107.16 and 107.17 of the Standard Specifications. Refer to the Project Special Provisions when the project includes a landscape maintenance period.

105.21.2 Final Acceptance

The Project Engineer will perform a final inspection, and the Contractor shall correct any unacceptable work before written final acceptance from CDOT is issued. See Section 120.3.2 for guidance on preparing the Final Acceptance Letter.

105.21.3 Form 1212 and SAP Workflow

1. Once a project is accepted in construction as complete, by either CDOT (Form 1212) or the Local Agency (Form 1212 LA), the Form workflow should be started in SAP. Starting the Form workflow can be done in one of two ways, depending on the type of project.
 - a. For CDOT administered projects in SiteManager®, the Form 1212 workflow is triggered automatically when the Project Acceptance Date is populated within SiteManager®. The workflow will be initiated in SAP the day after the acceptance date is entered. This date is automatically brought over to the SAP system and populates the same field in the Project Manager Custom Tab in transaction CJ20N. Please refer to the portion of the SAP Project Manager tab screen shot below:



A screenshot of a SAP Project Manager tab showing a field labeled "Proj Acceptance Date" with a date input box to its right. The field and box are highlighted in light blue.

This date will be automatically populated through SiteManager®. It can only be populated through this method for CDOT Administered construction projects. Note the box is grayed out or blue in color, which means that the user cannot complete it.

- b. Local Agency Projects, Non-Engineering Capital Projects, and Non-advertised side of combo projects: The Form 1212 LA workflow is triggered when the assigned Project Manager populates the Final Acceptance Date within the Project Manager Custom Tab in the SAP transaction CJ20N. The Form 1212LA workflow can also be triggered when the Project Manager populates the CDOT Final Acceptance Date in ZJ40LA. These project types do not manage construction activities through SiteManager® and the acceptance date must be entered manually. Please refer to the portion of the SAP Project Manager tab screen shot below:



A screenshot of a SAP Project Manager tab showing a field labeled "Final Acceptance Date" with a date input box to its right. The field and box are highlighted in light blue.

OR

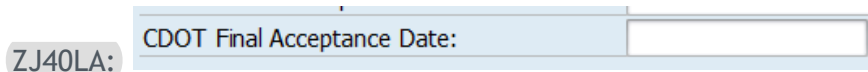

A screenshot of a SAP Project Manager tab showing a field labeled "CDOT Final Acceptance Date:" with a date input box to its right. The field and box are highlighted in light blue.

For local agency and non-engineering capital projects, Project Managers must manually populate the date in order to start the SAP Form 1212 LA workflow. Note the user can change the fields in white.

The Contract Award Amount in ZJ40LA must be entered before triggering the workflow in order to populate the field on the Form 1212 LA.

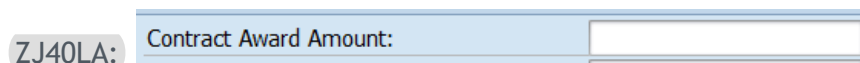

A screenshot of a SAP Project Manager tab showing a field labeled "Contract Award Amount:" with a text input box to its right. The field and box are highlighted in light blue.

2. Once the Form 1212 or Form 1212 LA workflow has been started, a Form 1212 / Form 1212 LA workflow item and outlook email message will be sent to all Resident Engineers within the project's region. The Resident Engineer managing the project should open this

workflow through transaction SBWP to save the workflow or to complete the Form. Please refer to the screen shot below:

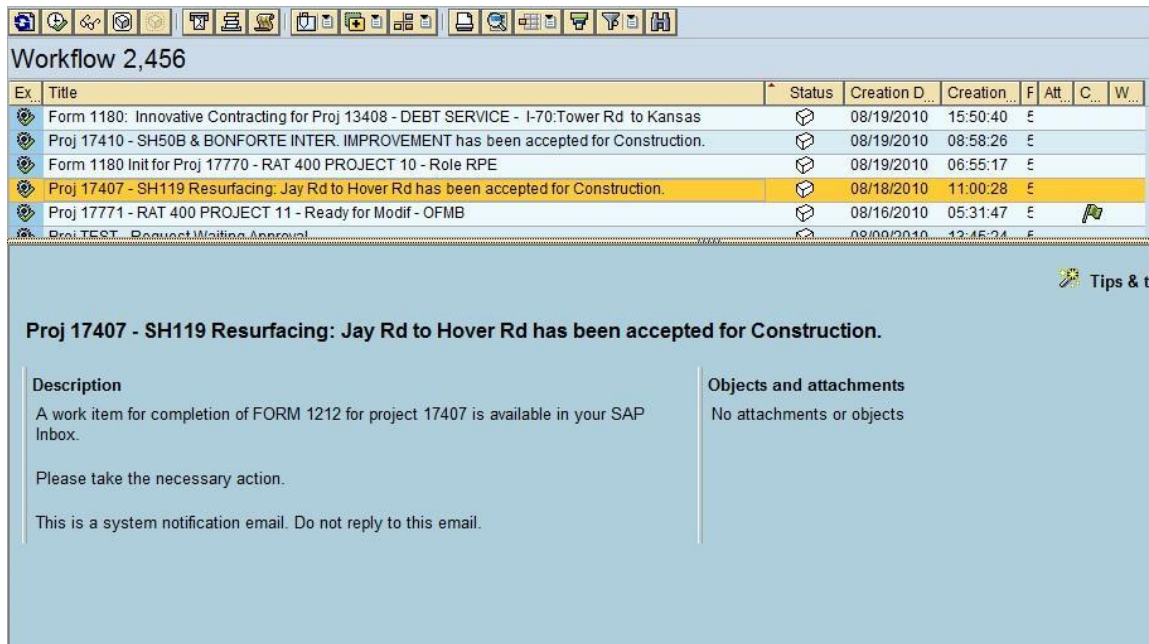

3. Upon opening the workflow message, the Form for the project will be ready for modification.
 - a. The top section of the Form 1212 has two fields that need to be completed by the Resident Engineer (Contractor's Name; Inspection Date). The top section of the Form 1212 LA has two additional fields that need to be completed by the Resident Engineer (Percent Time Elapsed; Original Contract Time). All other fields will be automatically populated using existing information within SAP. The Federal Oversight radio button is automatically selected based on the project information in SAP, but can be changed if necessary.

Please refer to the screen shot below:

The screenshot shows the "Final Acceptance for Federal Aid Projects: FORM 1212" form. The form is divided into several sections. The top section contains "Project No.:" (C 2911-003), "Project Code (SA#):" (22859), "Federal Oversight" (radio buttons for Yes and No, with No selected), and "County:" (CHAFFEE). The middle section contains "Contractor's Name:" (Western Gravel Constructors, L), "Location:" (Salida Pedestrian Improvements), "Original Contract Amount:" (1,127,477.00), "Description of Work as Advertised:" (ADA RAMPS AND OTHER IMPROVEME...), "Percent Time Elapsed:" (89.00), and "Original Contract Time:" (75). The bottom section contains "Inspection Date:" (03/14/2022) and "Acceptance Date:" (empty field with a calendar icon).

Final Acceptance for Local Agency Projects: FORM 1212 LA

Final Acceptance for Local Agency Project : Form 1212 LA

Project No.: BRO C010-114
Project Code (SA#): 20414
Federal Oversight: Yes No
County: JEFFERSON

Contractor's Name: Testing LA Contractor
Location: EVERGREEN LAKE RD OVER BEAR CRE.
Original Contract Amount: 762,000.00
Description of Work as Advertised: REMOVE AND REPLACE STRUCTURE
Percent Time Elapsed: 90
Original Contract Time: 300 Working
Inspection Date: 03/14/2022
Acceptance Date: 01/21/2022

- b. The bottom section of the form is the checklist of activities that should be complete as part of project acceptance. All activities must be evaluated before submitting the form.

Form 1212: The Resident Engineer can select whether or not the project included work on bridges or culverts with a span (or diameter) $\geq 4'$, tunnel, walls over 4' high, traffic signal structure and/or overhead sign structure. If one of the items listed above is included in the project, the Resident Engineer must evaluate the following checkboxes before submitting the form:

- i. Staff Bridge or the Engineer of Record has conducted a final inspection (walk-through) of all structures and determined the work is in reasonably close conformity with the plans and specifications, and
- ii. Bridge/Culvert $> 20'$ long or Tunnel: The CDOT Bridge & Structure Inspection and the Asset Management Engineer has been contacted for required NBIS/NTIS inspections.

Please refer to the screenshot below:

Final Acceptance for Federal Aid Projects: FORM 1212



Checklist-Verify the following items as complete and/or correct:

- The project has been completed in reasonably close conformity with the Contract Plans and Specifications including authorized changes.
- The Form 473 - Letter of Materials Certification has been completed.
- The project right-of-way appears to be free of unauthorized encroachments.
- The completed project has been reviewed for obvious safety deficiencies.

Select one of the following:

- 1. The project did not include work on bridges or culverts with a span (or diameter) $\geq 4'$, tunnel, walls over 4' high, traffic signal structure and/or overhead sign structure (Stop, if selected)
- 2. The project included work on bridges or culverts with a span (or diameter) $\geq 4'$, tunnel, walls over 4' high, traffic signal structures and/or overhead sign structure

If you selected 2 above verify the following:

- All Structures: Staff Bridge/Engineer of Record has conducted a final inspection (walk-through) of all structures on this project and determined the work is in reasonably close conformity with the plans and specifications. Supporting documentation shall include any structure related items to be addressed along with photos and date of inspection.
- Bridge/Culvert $> 20'$ long or Tunnel: The CDOT Bridge & Structure Inspection and the Asset Management Engineer has been contacted for required NBIS/NTIS inspections.

See Bridge Design Manual (Policies & Procedures, P3: Staff Bridge Managed Structural Assets) for definitions.

Remarks:



Form 1212 LA: The Resident Engineer can select whether or not the project included work on bridges or culverts with a span (or diameter) $\geq 4'$, tunnel, walls over 4' high, traffic signal structure and/or overhead sign structure. If one of the items listed above is included in the project, the Resident Engineer must evaluate the following checkboxes before submitting the form:

- i. All Structures: The Local Agency's Licensed Engineer in Responsible Charge of Construction (EIRC) has conducted a final inspection (walk-through) of all structures and determined the work is in reasonably close conformity with the plans and specifications, and
- ii. Bridge/Culvert $> 20'$ long or Tunnel: The CDOT Bridge & Structure Inspection and the Asset Management Engineer has been contacted for required NBIS/NTIS inspections.

Please refer to the screen shot below:

Final Acceptance for Local Agency Project : Form 1212 LA

including authorized changes.

The Form 473LA - Letter of Materials Certification has been completed.

The project right-of-way appears to be free of unauthorized encroachments.

The completed project has been reviewed for obvious safety deficiencies.

Select one of the following:

1. The project did not include work on bridges or culverts with a span (or diameter) $\geq 4'$, tunnel, walls over 4' high, traffic signal structure and/or overhead sign structure (Stop, if selected)

2. The project included work on bridges or culverts with a span (or diameter) $\geq 4'$, tunnel, walls over 4' high, traffic signal structure and/or overhead sign structure.

If you selected 2 above verify the following:

All Structures: The Local Agency's Licensed Engineer in Responsible Charge of Construction (EIRC) has conducted a final inspection (walk-through) of all structures on this project and determined the work is in reasonably close conformity with the plans and specifications. (The Engineer of Record is an acceptable substitute for the EIRC). Supporting documentation shall include any structure related items to be addressed along with photos and date of inspection.

Bridge/Culvert > 20' long or Tunnel: The CDOT Bridge & Structure Inspection and the Asset Management Engineer has been contacted for required NBIS/NTIS inspections.

See Bridge Design Manual (Policies & Procedures, P3: Staff Bridge Managed Structural Assets) for definitions.

Remarks:

- c. The Resident Engineer and date fields at the bottom of the form are automatically populated with the user initiating the workflow and the current date. These can be changed if needed.
- d. Click the “Submit” button to complete the Form. You will then be prompted to check the green checkmark.
- e. If the Resident Engineer is not ready to complete the Form 1212 or Form 1212 LA when he receives the workflow, then the workflow should be reserved with that Resident Engineer. Open the workflow item; then close it without completing it. It will show that this workflow is only in that Resident Engineer’s SAP business workplace. See screen shot below:

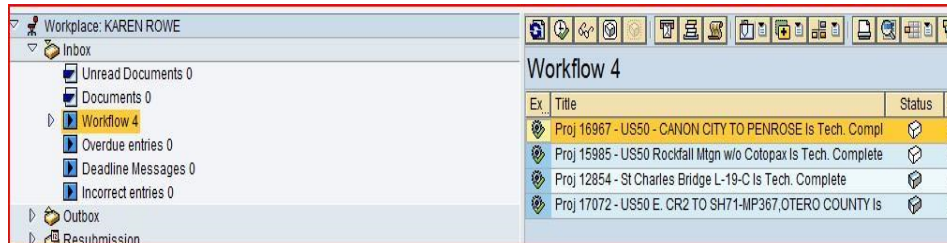

- f. The workflows only in the Resident Engineer’s workplace show a blue and white box under status. This is referred to as “reserving the workflow item.”
- g. The workflows in all the Region’s Resident Engineers' workplaces show a white only box.
- h. The Resident Engineer can come back to this reserved Form 1212 or Form 1212 LA workflow when he is ready to complete it.

- i. If you want to unreserve a Form 1212 or Form 1212 LA workflow and put it back in all the Region’s workplaces, highlight the workflow and then press the  submit button.

After the submit button is hit, the workflow is automatically completed and an email message is sent to all Resident Engineers indicating that the Form 1212 or Form 1212 LA is complete. The email will include a pdf copy of the completed form. The Resident Engineer should print the pdf copy, sign it and send the form with other project closure paperwork to the Region Finals Administrator.

For projects that do not require the Form 1212 or Form 1212 LA to be completed, the workflow can be bypassed and the business office can start project closure activities. These types of projects include design-only projects, property projects, DTD projects, maintenance projects, withdrawn projects, or any other projects that do not have a Construction phase.

- j. For these projects, the Business Manager or designee can mark the Form 1212 / Form 1212 LA status in CJ20N for the project and save the project. Once this status is set, the business office can set the TECO status and begin project closure activities and the Form 950 workflow. Please refer to the screen shots below:

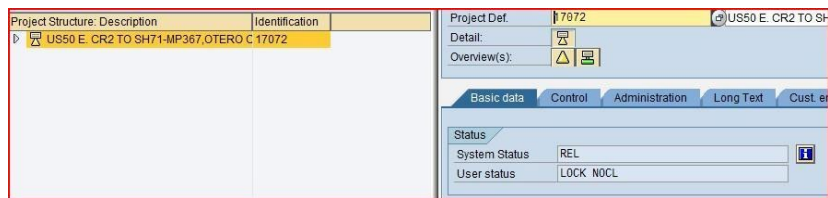

Hit the blue “i” button at the top level of the project. Then the following screen will appear.

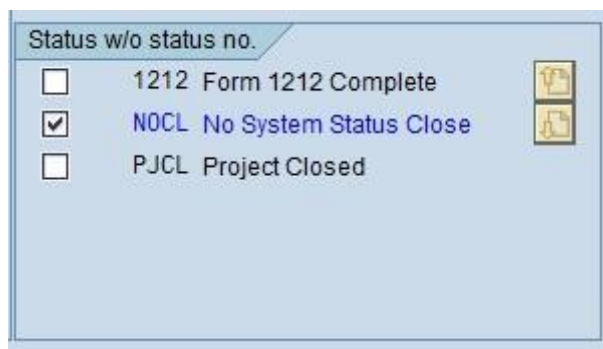

What do I do if I lost the Form 1212 or Form 1212 LA workflow?

There is now a workflow report available that will allow anyone to see where any workflow is located. It may be in another RE’s SAP workplace and this report will indicate the location. The report is located in the Portal under the Report tab, then under Project Systems. If help is needed with the report, contact your region Super User or the SAP Project Systems support team.

What do I do if I want to run the Form 1212 or Form 1212 LA workflow again?

There is no way in the system to easily re-run a Form 1212 / Form 1212 LA workflow that has already been completed. If the Form 1212 / Form 1212 LA that was created is needed or if the workflow needs to be restarted, the SAP Project systems support team will need to be contacted.

Please contact the SAP Project Systems Business process experts.

105.22 DISPUTE RESOLUTION

105.22.1 General

Contract adjustments and dispute resolutions will be:

1. based on Contract documents and factual information;
2. objective and impartial (i.e., unaffected by individual personalities); and
3. fair and reasonable.

The dispute and claim resolution processes are business processes that are sometimes necessary to resolve differences between CDOT and Contractors. The intent of the processes is to resolve issues early, efficiently, and as close to the project level as possible. In the event of a dispute, the Project Engineer will contact the Area Engineer. Refer to Appendix D for the Disputes and Claims Flow Chart (Figure 105-1).

105.22.1.1 Dispute and Claims Evaluations

Adjustments or resolutions must be based on the Contract documents and factual information. Doing otherwise encourages frivolous disputes and claims that are not in the best interest of the Department. All CDOT project personnel must maintain accurate and timely records throughout the project. For Administrative, settlements see Section 120.7.2 of this Manual.

105.22.1.2 Dispute and Claim Status Report

The Construction Engineering Services Branch is responsible for preparing and forwarding a quarterly Dispute and Claims Status Report to the Chief Engineer. Therefore, it is essential that Project Engineers monitor the status of each dispute or claim on their respective projects. To assist with this task, Project Engineers shall use the Form 1318, Dispute and Claim Status Report Form (see Appendix B), which is available from the Forms Catalog website or in electronic format from the Construction Engineering Services Branch. Submit the form to your Area Engineer whenever the status of a dispute or claim changes. The Dispute and Claim Status Report Form presents a list of key events that are time sensitive in processing disputes and claims.

105.22.1.3 FHWA Involvement

Title 23 Code of Federal Regulations 635.124 defines the extent to which Federal-Aid highway funds may be used to participate in awards and settlements of construction contract disputes and claims brought by contractors against state highway agencies. The Project Engineer will provide the FHWA Operations Engineer with written notification upon receipt of the formal notification of intent to file a dispute from the Contractor when the dispute meets the following requirements:

1. all disputes exceeding \$250,000 on Federal-Aid projects; and
2. all disputes on full oversight projects.

The written notification shall be followed up with copies of all dispute information. Upon notification, the FHWA Operations Engineer will determine the appropriate level of FHWA involvement. Note that it is not necessary to involve the FHWA Operations Engineer on State-funded projects where there is no FHWA involvement.

105.22.2 Dispute Processing Procedures

105.22.2.1 Dispute Notification

The contract requires that disputes must be based on the requirements of the Contract documents (e.g., Contract Plans, Standard Specifications, and Special Provisions). Upon failure of the Parties to resolve an issue through negotiations and the Contractor elects to escalate the dispute, the Contractor must provide the Project Engineer with immediate written notice of dispute. Upon receipt of this notice, the Project Engineer should perform the following:

1. **Acknowledge Receipt.** Upon notification, the Engineer should respond with a letter that includes the following sample language. “CDOT is in receipt of your notice of dispute in regard to_____. Your Request for Equitable Adjustment (REA) is due 15 days from the date of your notice of dispute letter, dated _____.”
2. **Alert AE.** Notify your Area Engineer of the Project Engineer’s receipt of a “notice of dispute.”
3. **Contract Specifications.** Review the requirements of subsection 105.22 of the contract. Pay particular attention to specified time requirements.
4. **Seek Guidance.** Upon notification of a dispute, the Project Engineer will seek advice and concurrence from the Resident Engineer and the Region Program Engineer. In addition, the Project Engineer will contact and discuss each dispute with the Area Engineer before rendering a decision.
5. **Gather Supplemental Data.** Document all pertinent details as soon as practical after receiving notification, and immediately implement procedures to document the disputed work completely and accurately. Such records may include:

- a. Force Account Records. Force account records of the disputed work must be on Form 10 - Inspector's Report for Force Account Work. For information on Force Account, see Section 109.4 and Appendix B of this Manual.
- b. Conversations. Accurately document conversations, agreements, and actions taken by the Contractor, Project Engineer, or other CDOT personnel regarding the disputed work on CDOT Form 103, Daily Diary.

Do not editorialize. Be factual and cite the Contract requirements.

- c. Photographs/Videotape. Where appropriate, take photographs and videotape of the disputed work. Follow the steps in Section 120.1.3.6. Be careful what is stated near audio microphones during videotaping.

105.22.2.2 Review of REA Package

The Project Engineer is responsible for reviewing the Contractor's REA package.

The review must be complete and thorough. Consider the following guidelines:

1. Check REA Package. Disputes will not be considered unless the Contractor has first complied with the resolution processes as specified in subsections 104.02, 106.05 and 108.08. Compare the REA package to the Contract documents (e.g., Contract Plans, Standard Specifications, and Special Provisions) and the CDOT project records to ensure there exists a contractual and factual basis for the dispute. The contractor shall provide the estimated dollar cost of the dispute with supporting documentation, and an analysis of the progress schedule showing the schedule change or disruption. The package needs to be specific in order for CDOT to evaluate the elements being disputed, so that other elements are not drawn into the dispute. The Contractor is allowed to supplement the REA as additional information becomes available.
2. Request Additional Information. If it is determined that additional information or clarification is required from the Contractor to review the REA package, notify the Contractor in writing clearly stating the information required, why the information is required, and a reasonable response date. Acknowledge receipt of the information in writing. The request for additional information letter should give the Contractor 10 days to provide missing information. Only the information submitted as part of the REA or supplemental REA will be considered in the decision for merit.
3. Seek Guidance. Seek advice and concurrence from the Resident Engineer and the Region Program Engineer. In addition, the Project Engineer will contact and discuss each dispute with the Area Engineer before rendering a decision. If the dispute involves legal issues or legal questions, the Area Engineer, after discussing the issue with the Resident Engineer, will consult the Attorney General for guidance.
4. Request Audit. An audit may be performed for any dispute. The audit will evaluate the amount of the Contractor's damages but will not make judgment on merit or quantum. In certain cases, there are damages that are the fault of both Parties and a determination of value to be assigned to each Party will have to be negotiated. If the decision is made to perform an audit, the Project Engineer will request the audit as soon as practical after

receiving the complete REA or dispute. The Project Engineer will contact the Area Engineer to assist in the determination of the scope of the audit.

5. **Use of Consultants.** If the Project Engineer feels additional help with the dispute is warranted, he will consult with his Resident Engineer for approval to use a consultant. Complex or multiple delay issues are difficult to analyze, and such analyses are a complex and time-consuming task that may be more effectively performed by a consultant. Consultants can help determine the impacts of delays, the validity from a contractual and legal standpoint, and the compensation due, if any. A thorough analysis and a fair assessment of entitlement issues can sometimes help resolve the dispute at an early stage. The Construction Engineering Services Branch has contracts in place to assist projects with disputes and claims. Contact the Area Engineer for additional information.

105.22.2.3 Project Engineer Decision

The Project Engineer will follow the requirements of subsection 105.22(c) of the Contract and render a decision within the timeframes specified. This determination will include a summary of the relevant facts, Contract provisions supporting the determination, and an evaluation of all scheduling issues that may be involved. The determination may include both merit and quantum, but quantum may be determined separately. Merit may be granted, but the quantum may continue to be disputed and follow the dispute resolution process through the Dispute Review Board, or through the claim process.

105.22.2.4 Resident Engineer Review

If the Contractor rejects the Project Engineer decision of merit or quantum, the Resident Engineer (RE) will follow the requirements of subsection 105.22(d) of the Contract. If the meetings with the RE do not result in a resolution or the participants mutually agree that they have reached an impasse, the dispute shall be presented to the Dispute Review Board in accordance with subsection 105.23 of the Contract.

105.23 DISPUTE REVIEW BOARD

The Project Engineer will initiate the Dispute Review Board (DRB) process in accordance with subsection 105.23(a) of the Contract when a dispute has not been resolved. Select DRB members based upon their experience, knowledge relevant to the project and their availability. When contacting prospective DRB members, let them know who the project participants (contractor, subcontractors, project personnel, etc.) are so that a conflict-of-interest situation can be avoided.

Once DRB members have been selected, notify the Area Engineer so the AE can obtain concurrence from the Attorney General. Upon approval of DRB members, submit the Third-Party Agreement to the Area Engineer for signature by the Chief Engineer.

The Pre-Hearing submittal shall include a pre-hearing position paper containing the information required in subsection 105.23(e) of the Contract. A joint statement describing the dispute is part of the position paper. If the parties are unable to agree on the wording, see the specification for suggested wording of this document. Both parties need to be able to agree

upon what is being disputed. This is a fundamental part of the dispute process. The DRB shall hear only those disputes identified in the written request for the DRB and shall review only the information contained in the pre-hearing submittals. The pre-hearing submittal shall only contain information that was shared and discussed with both parties during the Project and Resident Engineer review meetings. Therefore, consider including the following documents in the pre-hearing submittal:

1. Contract Plans,
2. Standard Specifications,
3. Special Provisions,
4. Standard Plans,
5. shop drawings,
6. reports from consultants,
7. reports from auditors,
8. schedules and schedule updates,
9. schedule analysis,
10. Schedule narratives,
11. project diaries,
12. correspondence,
13. engineering memos,
14. inspection reports,
15. time counts, and
16. pay estimates.

If the parties are unable to resolve the dispute after the DRB process, the contractor may escalate the dispute to a claim.

105.24 CLAIMS FOR UNRESOLVED DISPUTES

When the dispute is not resolved at the Resident Engineer level, the Project Engineer will continue to be involved with the process by maintaining the claim record and ensuring the specification is followed.

105.24.1 Official Claim Record

The official claim record consists of CDOT's documents and the Contractor's claim package along with any additional documentation developed during the claim process.

Development of Claim Record

1. Contractor submits 5 copies of the Contractor claim package to RTD
2. Project Engineer prepares 5 copies of the CDOT claim package
3. Project Engineer is responsible for getting all the packages together and creating 5 Claim Records
4. The Project Engineer is responsible for maintaining these 5 records while the RTD reviews the Claim. This includes adding:
 - a. any correspondence related to the claim between the Contractor and RTD,
 - b. minutes or notes from the RTD hearing,
 - c. any additional information provided to render a decision, and
 - d. the RTD Decision letter
 - e. This can be done by providing electronic copies of these documents to the person with a copy of the claim record.
5. When the RTD issues a written Decision, a copy of the Record is returned to the Contractor.
6. If the claim is appealed to the Chief Engineer, the Area Engineer will be responsible for maintaining the four remaining copies of the claim record. The Area Engineer will add the following documents to the claim records:
 - a. the Contractors appeal to the Chief,
 - b. any correspondence related to the claim between the Contractor and the Chief,
 - c. minutes or notes from the Chief Engineer hearing,
 - d. any additional information provided to render a decision, and
 - e. the Chief Engineer's Decision letter.
7. To assist with review of the Claim Package, the Project Engineer and/or the Area Engineer may prepare a summary of the claim record for the RTD and Chief's review of the claim. Oftentimes a Contractor will submit large volumes as the claim package; this summary is intended to help the RTD and Chief to understand the claim.

Claim Record Distribution

Record Copy	RTD Level	Chief Level
1	Contractor	Contractor
2	RTD	RTD (Region Use)
3	Project Engineer or RE	Area Engineer
4	Unassigned	Chief
5	Unassigned	Attorney General (if necessary)

Figure 100 - 2

Consider the documents listed in subsection 105.23 of this Manual when preparing the claim record.

Once the claim record has been assembled by the Project Engineer, the submission of additional information, other than subsequent levels of review, will not be permitted.

105.24.2 RTD Decision.

The RTD will render a written decision within 60 days after receipt of the official claim package or receipt of the audit, whichever is later.

105.24.3 Chief Engineer Decision.

The Contractor may appeal the RTD decision within 30 days to the Chief Engineer. Within 15 days of the appeal, either party may submit a written request for a hearing with the Chief Engineer. The Chief Engineer will render a written decision within 60 days after receipt of the official claim package and will only consider information contained in the claim package.

105.24.4 De Novo Litigation or Merit Binding Arbitration.

If the Contractor rejects the Chief Engineer’s decision, the Contractor may initiate de novo litigation or merit binding arbitration depending on the option selected by the Contractor on Form 1378 submitted at the Preconstruction Conference.

SECTION 106 CONTROL OF MATERIAL

106.1 SOURCE OF SUPPLY AND QUALITY REQUIREMENTS

The Contractor is required to not use or enter on any private property until the Contractor has furnished the Project Engineer with a copy of the original signed agreement between the Contractor and the property owner. Private property includes, but is not limited to, dumps, storage yards, haul roads, and plant sites. The Project Engineer will retain the copy in the project records and note in the project diary that it was received.

106.2 RESERVED

106.3 SAMPLES, TESTS, CITED SPECIFICATIONS

Obtaining timely turnaround of test results is vital to the successful construction of a project. This is important for all of the testing whether it is the Contractor conducting the tests for Process Control, or the State conducting the tests for Quality Assurance. Refer to the CDOT Field Materials Manual for additional guidance.

106.4 QUALIFICATION OF TESTING PERSONNEL AND LABORATORIES

Personnel performing any type of testing on a project shall be certified in accordance with the CDOT Field Materials Manual.

106.5 SAMPLING AND TESTING OF HMA

All HMA, Item 403, except HMA (Patching) and temporary pavement shall be tested in accordance with the specifications and the CDOT Field Materials Manual.

106.6 SAMPLING AND TESTING OF PORTLAND CEMENT CONCRETE PAVING

All Portland Cement Concrete Pavement, Item 412, shall be tested in accordance with the specifications and the CDOT Field Materials Manual.

106.7 - 106.10 RESERVED

106.11 BUY AMERICA REQUIREMENTS

With the exception below, the Contractor shall provide steel and iron products for permanently incorporated elements, for which all manufacturing processes have occurred in the United States.

For definitions of steel and iron, products refer to the Special Notice to Contractors in the Field Materials Manual.

This requirement applies to all steel and iron products, including donated materials, which are permanently incorporated into the project.

Contractor shall maintain a document summarizing date and quantity of all steel and iron material delivered to the project. Document shall show pay item, quantity of material delivered to the project, along with quantity of material installed by cutoff date for monthly progress payment. Summary shall also reconcile pay item quantities to the submitted Buy America Certifications. The Contractor shall also maintain documentation of project delivered cost of all foreign steel or iron permanently incorporated into the project. Both documents shall be submitted to the Engineer within five days of the cutoff date for monthly progress payment. A monthly summary shall be submitted even if no steel or iron products are incorporated into the project during the month. The summary document does not relieve the Contractor of providing necessary Buy America Certifications of steel and or iron prior to permanent incorporation into the project.

Bid items that include steel and iron products will not be paid for in a monthly pay estimate until the Contractor complies with the Buy America specification.

Contractor shall provide documentation of the project delivered cost of all foreign steel or iron permanently incorporated into the project, if any.

The practice of making items non-participating to circumvent the Buy America provisions is prohibited.

The Contractor may use a minimal amount of foreign steel. The total cost of all such foreign steel, which includes the cost of delivering the steel to the project, shall not exceed one-tenth of one percent of the total Contract cost or \$2,500, whichever is greater.

There is no clear-cut rule for resolving an after-the-fact discovery of an inadvertent incorporation of an excess amount of foreign materials into a project. Each situation must be resolved on a case-by-case basis and approved by the FHWA.

All Buy America waiver requests must be submitted to the FHWA Office of Program Administration for consideration. The waiver request will be posted on the internet for public comment for 15 days before FHWA action is taken. They will be posted at “Notice of Buy America Waiver Request.”

<http://www.fhwa.dot.gov/construction/contracts/waivers.cfm>

Waiver requests that are based on an adverse impact to a contractor’s construction schedule will not be accepted when domestic material is available.

The Contractor shall maintain a document summarizing the date and quantity of all steel and iron material delivered to the project. The document shall show the pay item, quantity of material delivered to the project, along with the quantity of material installed by the cutoff

date for the monthly progress payment. The summary shall also reconcile the pay item quantities to the submitted Buy America certifications. The Contractor shall also maintain documentation of the project delivered cost of all foreign steel or iron permanently incorporated into the project, if any. A summary of both sets of documentation shall be submitted to the Engineer within five days of the cutoff date for monthly progress payment. A monthly summary shall be required even if no steel or iron products are incorporated into the project during the month. Summary document does not alleviate the requirement to provide the necessary Buy America Certifications of steel and or iron prior to permanent incorporation into the project.

Glass Beads for Pavement Marking. All post-consumer and industrial glass beads for pavement marking shall have been manufactured from North American glass waste streams in the United States of America. Bead manufacturer shall submit a COC in accordance with subsection 106.12 confirming that North American glass waste streams were used in the manufacture of the glass beads.

106.12 CERTIFICATES OF COMPLIANCE

The Project Engineer must be in receipt of all original material certifications with an original signature before payment is made for the Contract item. For details and the language required on the Certificate of Compliance see subsection 106.12 of the Standard Specifications and Standard Special Provision, Revision of Section 106 - Certificates of Compliance and Certified Test Reports.

106.13 CERTIFIED TEST REPORT

The Project Engineer must be in receipt of all original material Certified Test Reports, with an original signature, before payment is made for the Contract item. For details and the language required on the Certified Test Report, see subsection 106.13 of the Standard Specifications and Standard Special Provision, Revision of Section 106 - Certificates of Compliance and Certified Test Reports.

SECTION 107 LEGAL RELATIONS AND RESPONSIBILITY TO THE PUBLIC

Section 107 of the Standard Specifications requires that all laws and regulations including those of Federal, State, and local jurisdictions, be observed by both Contractor and CDOT personnel.

107.1 LAWS TO BE OBSERVED

By reference, subsection 107.01 of the Standard Specifications incorporates legal statutes and requirements of the Davis-Bacon Act, Equal Employment Opportunity, Occupational Safety and Health Administration, Mine Safety and Health Administration, and other legal regulations related to CDOT construction contracts.

107.1.1 Davis-Bacon Act

The United States Department of Labor and the Federal Highway Administration delegate to the Department the responsibility for enforcing the Davis-Bacon Act, the Contract Work Hours and Safety Standards Act, and the Copeland Anti-Kickback Act. The provisions of these acts respectively govern payment of minimum wage, payment of overtime wage, and prevention of Contractor kickbacks. The Davis-Bacon Act specifically governs payment of minimum wage and applies to all Federal-Aid highway construction contracts and subcontracts exceeding \$2,000, except those for local roads and rural minor collectors. Senate Bill 19-196 requires the Department of Transportation to apply the requirements of the federal “Davis-Bacon Act” to all projects advertised on or after July 1, 2021 regardless of project size or funding type (this includes CDOT projects that are fully state-funded). Local Agency state-funded projects are excluded from this requirement.

107.1.1.1 FHWA Form 1273

The FHWA Form 1273 - Required Contract Provisions - Federal-Aid Construction Contracts must be incorporated directly into Federal-Aid Contracts, including subcontracts and lower tier subcontracts. The applicable requirements of Form FHWA-1273 are incorporated by reference for work done under any purchase order, rental agreement or agreement for other services. The Contractor shall be responsible for ensuring compliance of all subcontracting and supplying entities. The Project Engineer or Region Civil Rights Office must discuss these requirements with the Contractor and subcontracting entities at the Preconstruction Conference.

107.1.1.2 Weekly Payrolls

Weekly payrolls are required from all Contractors and subcontractors.

Contractor and all tiers of subcontractors: Submission of weekly payrolls (at least every seven days) is required.

Suppliers: When the criteria outlined in Specification 106.01 is met, submission of weekly payrolls (at least every seven days) is required.

Prime Approver: Prime Contractor reviews and approves or rejects all payrolls submitted by their own company as well as all subcontractors and applicable suppliers.

CDOT Project Engineer or designee: Accepts or rejects all submitted payrolls

Using the payroll review checklist

(https://www.codot.gov/business/civilrights/compliance/assets/lcptracker-payroll-review-checklist_05-21.pdf), the CDOT Project Engineer or designee will review 100% of the first four performing payroll submissions of the Contractor, each subcontractor, and each Supplier (if required to be submitted). If the CDOT Project Engineer or designee has determined that the firm has demonstrated compliance in payroll submissions, the individual may determine to reduce reviews to 10% of each firm's payrolls submitted thereafter. If the firm does not demonstrate compliance, the individual may determine to increase the percentage of reviews. All submitted payrolls must be accepted by the CDOT Project Engineer or designee in the LCPtracker system within 14 days of submission from the Prime Approver.

107.1.2 Processing Requests for CDOT Records

Requests for access to CDOT public records must be forwarded to the Department in writing (see CDOT Procedural Directive 51.2 - Public Inspection of Department Records). The Colorado Open Records Act requires CDOT to respond to inquiries for information within three days of the written request.

107.1.3 Disadvantaged Business Enterprises

107.1.3.1 Utilization Plan

For all federal aid projects with a DBE goal greater than zero, the Contractor shall have an approved DBE Utilization Plan (UP) prior to contract award. The UP lists the DBE commitments the Contractor shall use to meet the DBE contract goal. The Project Engineer and regional staff can view the UP in B2GNow under Proposals. Additionally, when the Civil Rights and Business Resource Center creates the contract in B2GNow, the commitments presented in the UP are transferred into the contract. They are designated by a red exclamation point until a Form 205 or Form 1425 is received and approved by the CRO. For more information, see the [DBE Participation Training Resources](#) section of the Civil Rights and Business Resource Center.

107.1.3.2 Sublet Permit Application

While the CRO is responsible for reviewing the Form 205 to ensure the Contractor is acting in accord with his DBE commitments, the Project Engineer should also be familiar with the commitments and watching for inconsistencies with the original commitments. The Project

Engineer or CRO may withhold approval of a DBE or non-DBE Form 205 if the work items in the Form 205 are inconsistent with the UP.

The Contractor may add new DBEs to the project using the Form 205. Listing a DBE on the Form 205 does not create a DBE commitment subject to the termination and reduction procedures. The CRO will review the Form 205 to verify that the DBE participation is eligible to count toward the DBE contract goal. If approved, the CRO will add the DBE as for credit participation in B2GNow. Verified participation can count toward the contract goal in the event of the need for a substitution or for increases in the project, which raise the dollar value of the project goal.

107.1.3.3 Utilization Plan Modifications

The Contractor must make good faith efforts to meet the DBE goal and to fulfill each separate DBE commitment listed in the UP. Regardless of whether the goal is met, if the Contractor does not use the listed DBE to perform the work of the commitment, CDOT cannot pay the Contractor for the work performed unless the termination and reduction processes were followed. Additionally, the Contractor cannot make modifications to the DBE commitments without CRO approval. Increases in quantities are not considered modifications and do not require CRO approval.

If the Contractor is seeking to terminate, reduce, modify, or make a substitute DBE commitment, the contractor must submit the Form 1420 to the CRO, with a copy to the Project Engineer, for approval. DBE participation verified via Form 205 may count as substitute participation. At his discretion, the CRO may request a Form 1415, Commitment Confirmation. When a Form 1415 is requested and the Form 1420 approved, the commitment then becomes subject to enforcement like an original UP commitment.

The CRO will review the Form 1420 and provide a concurrence or denial on the form and return it to the Contractor with a copy to the Project Engineer. The CRO will also make the commitment modifications and upload all 1420s in B2GNow. Regions should follow the standard escalation procedures if a dispute regarding good faith efforts arises between the Contractor and CDOT.

Contractors, Project Engineers and the CRO can use B2GNow to track the progress of the Contractor towards fulfilling the Utilization Plan and meeting the contract goal. The original Utilization Plan is available under the Proposals. The current contract participation is available by going under “Search” and then “Contract” and searching for the applicable contract. The information is provided on the Compliance Audit Summary tab.

107.1.3.4 Change Orders

At the end of the project, the calculation of whether the Contractor has met the goal is based upon the Total Earnings Amount. This includes all work issued via change orders. Therefore, if the Contractor receives change orders during the project which increase the work to be performed, the Contractor must ensure that he makes good faith efforts to obtain additional DBE participation. If the Contractor is unable to obtain additional participation, the Contractor must request a waiver via Form 1420.

107.1.3.5 Commercially Useful Function

Project Engineers are responsible for overseeing the daily activities of firms and ensuring that DBEs are performing a commercially useful function. At the completion of the DBE's work, the DBE, Contractor and Project Engineer must each complete their respective portion of Form 1432 and submit it to the CRO. The DBE's participation cannot count toward the contract goal unless a Form 1432 is submitted. The CRO may conduct additional in depth commercially useful function reviews. These will be stored in B2GNow.

107.1.3.6 Withholding Payment and Sanctions

If the Contractor does not use the listed DBE for the work stated in the commitment, then the Project Engineer should withhold payment to the Contractor for such work.

At the end of the project, the CRO will review the Contractor's compliance and good faith efforts to fulfill the commitments and meet the contract goal. The Project Engineer shall not release retainage or withheld amounts until the CRO has determined whether the Contractor shall be subject to sanctions. In the event the amount of sanctions exceeds the amount withheld, the CDOT shall seek reimbursement from the Contractor for the balance of the sanctioned amount.

107.1.4 On-the-Job Training

For more information or assistance with the application of the OJT requirements please contact your Region Civil Rights Office (CRO) or the OJT Program Coordinator at the Civil Rights and Business Resource Center, 303-757-9234

107.1.4.1 Preconstruction Conference Requirements

At the Preconstruction Conference the Project Engineer or if available, the CRO representative will discuss the Project's On-the-Job Training (OJT) goal and the OJT requirements. An emphasis will be placed on noncompliance resulting in the withholding of payments and the assessment of disincentives against the Contractor at the end of the project. If the Contractor does not comply by the end of the project, he is subject to disincentives.

107.1.4.2 Enrolling Trainees and Apprentices

The Contractor shall enroll all trainees and apprentices by submitting a Form 838 - OJT Trainee/Apprentice Record and one of the following as supporting registration documentation to the Project Engineer ten working days before the trainee or apprentice starts work onsite.

Type of Program	Documentation Required
Standard Training Program	Form 838, <i>plus</i> Copy of the Contractor's Standard OJT Training Program's Approval Letter signed by CDOT and FHWA - or -

	Colorado Contractors Association Manpower Training Program Acceptance Form
U.S. Department of Labor Approved Apprentices	Form 838, <i>plus</i> US DOL - Program Registration and Apprenticeship Agreement - Form ETA 671 - Section II - or - US DOL - Office of Apprenticeship, Apprenticeship Certification with the Apprentice's name on this list

Figure 100 - 3

The Project Engineer will forward the form to the CRO for approval. The CRO will review and respond within ten working days. If the Contractor has not submitted the OJT Form 838 and registration documentation to the Project Engineer at least ten working days prior to the first progress payment, the Project Engineer will send a Form 105 - Speed Memo to the Contractor. The Form 105 will remind the Contractor of the OJT goal, the possibility of progress payments being withheld, and the possible assessment of disincentives for non-compliance. The Project Engineer will remind the Contractor at the weekly project meetings about the OJT goal and the Contractor's status towards the goal. The Project Engineer will follow up with the issuance of a Form 105 memo as appropriate.

When a trainee or apprentice is approved by the CRO, the Contractor shall submit the hours worked on the project by the trainee/apprentice on a Form 832 - Trainee Status and Evaluation. The form is due monthly and requires approval of the Project Engineer. The Project Engineer should review the project hours for reasonableness in comparison to the certified payrolls, daily diaries, or other project observations. The Project Engineer will initiate payment from the OJT force account for hours worked on the CDOT project site and found to be reasonable at the rate of \$10.00 per hour. A copy of Form 832 shall be sent to the CRO each month. At no time should the OJT force account be paid as a lump sum pay item.

107.1.4.3 Increasing OJT Hours

The Contractor will be reimbursed for no more than the amount outlined in the OJT force Account budget.

107.1.4.4 Offsite OJT Hours

Offsite OJT Hours will not count toward the OJT goal.

107.1.4.5 OJT Goal Waiver or Modification

The Contractor or the Project Engineer may initiate a waiver or modification of the OJT goal. If the Contractor requests that the OJT goal be waived or modified, a written explanation shall be submitted. Once a written request is received or the Project Engineer determines a waiver or modification is warranted, the Project Engineer will notify the CRO. The Project Engineer

with the CRO will decide whether to approve the waiver or modification and if approved, a Form 1336 - Waiver Request for Contract's On the Job Training Hours will be completed by the Project Engineer. If applicable, it should include the Contractor's request as an attachment. The CRO will have ten working days to review and approve Form 1336. If Contractor's request for a waiver or modification is denied, the Project Engineer will notify the Contractor in a Form 105. Examples of when a waiver or modification should be considered are:

1. when the work a trainee or apprentice performs is a safety hazard that cannot be mitigated and was unknown at the time the goal was developed;
2. if there was a change of scope that eliminates the work that would have been performed by a trainee or apprentice and there are no other opportunities for the trainee or apprentice; and
3. any other efforts to meet the goal such as a Contractor soliciting OJT participation from the subcontractor.

107.1.4.6 Not Meeting the OJT Goal

If the Contractor does not meet the required OJT goal, the Project Engineer will notify the CRO prior to Final Acceptance of the project. The Project Engineer will issue a Form 105 requiring the Contractor to submit a written explanation for not meeting the OJT goal. When the Contractor provides a written explanation, the Project Engineer and the CRO will confer to determine whether disincentives should be imposed, and in what amount. If the Contractor does not provide a written explanation or the explanation provided is not satisfactory to CDOT, disincentives will be assessed against the Contractor. The CRO will determine the journeymen's rates to be used to calculate disincentives. The Project Engineer will notify the Contractor of the decision using Form 105.

107.1.4.7 Assessing OJT Disincentives in SiteManager®

In SiteManager®, add a change order (Reason code: No MCR/CMO required) for the calculated disincentives. Use Category 0200; use only item code 900-00028, Added Item/OJT Disincentives. This disincentive is a per hour type item. Enter the hourly rate as a positive and the quantity of hours as a negative. Remember to post to your DWR. For further information and assistance with SiteManager® entry, please contact the AASHTOWare Project Manager at systemsupport@cdot.mojohelpdesk.com.

107.1.5 Equal Employment and Civil Rights Considerations

107.1.5.1 Discrimination and Sexual Harassment Complaints

Discrimination and sexual harassment complaints must be kept confidential and forwarded immediately to the Region EEO/Civil Rights Specialist for action.

107.1.5.2 Form 280

Form 280 - EEO and Labor Compliance Verification will be used to document compliance with both Equal Employment Opportunity (EEO) and Labor Compliance as required by federal regulations. Form 280 interviews are required on all projects (i.e., federal aid construction projects, local agency projects, maintenance projects and state funded only projects). All projects require the “Equal Employment Opportunity” section to be completed. The “Labor Compliance” section is only completed when Davis-Bacon wages are required on the project.

Each Region Civil Rights Manager will create a process to report the number of interviews required and completed. The actual interview forms shall be retained in the project records. A copy should be forwarded to the Region Civil Rights Manager for follow-up action if problems are noted. Region Civil Rights Manager will report data for each residency to the Labor and Contract Compliance Officer in the Civil Rights and Business Resource Center on a quarterly basis. The report will indicate the number of interviews required, completed, and forwarded for follow up action. The Labor and Contract Compliance Officer will prepare a summary report for the Chief Engineer.

Project personnel will conduct interviews in accordance with the following table:

Contract Amount	Interviews Required
Up to \$20 million	4 interviews during each month of active construction
Greater than \$20 million and up to \$100 million	8 interviews during each month of active construction
Greater than \$100 million and up to \$200 million	12 interviews during each month of active construction
Greater than \$200 million and up to \$300 million	16 interviews during each month of active construction
Greater than \$300 million	20 interviews during each month of active construction

Figure 100 - 4

Please note field personnel should prioritize interviews by:

1. Interviewing women and minorities on the workforce in order to monitor potential discriminatory actions
2. Rotating the interviews among the prime and subcontractors on the project
3. Rotating the interviews among various labor classifications, with emphasis on the more heavily utilized classifications

Questions regarding this process may be referred to the Labor and Contract Compliance Officer in the Civil Rights and Business Resource Center at 303-757-9540.

General Provisions

The sample spreadsheet below may be used by the Project Engineer for tracking Form 280 interviews

	A	B	C	D	E
1	Project Tracking Form for EEO interviews using Form 280				
2	Project Number/Code:				
3	Original Contract \$\$:				
4	Start of work date:				
5	Standard # of Form 280s required monthly (from chart):				
6		# of	# of	# Form 280s	
7		Form 280s	Form 280s	forwarded for	
8	Reporting Period	required	completed	follow-up action	Comments
9	July (year)				
10	August (year)				
11	September (year)				
12	Quarterly totals				
13	October (year)				
14	November (year)				
15	December (year)				
16	Quarterly totals				
17	January (year)				
18	February (year)				
19	March (year)				
20	Quarterly totals				
21	April (year)				
22	May (year)				
23	June (year)				
24	Quarterly totals				

Figure 100 - 5

107.1.5.3 FHWA Form 1391

The FHWA Form 1391 - Federal-Aid Highway Construction Contract Annual EEO Report is required each year from all Contractors and subcontractors working on Federal-Aid projects, including Local Agency projects, that are active during the last week of July. The Region EEO/Civil Rights Specialist will establish the timetable for processing these reports. Each construction firm shall disclose its respective project workforce or submit a Form 1391 with a “No Work” statement, for the one-week period designated by the Region EEO/Civil Rights Specialist. Only the project data for the designated one-week period will apply. Once completed, the reports will be submitted to the Project Engineer and forwarded to the Region EEO/Civil Rights Specialist for review and processing.

107.1.6 Drug-Free Workplace

Subsection 107.06 (b) of the Standard Specifications requires that Contractors, subcontractors, and suppliers participating in CDOT construction contracts maintain and enforce a drug-free workplace policy. Incidents occurring on a CDOT construction project will be handled in accordance with subsection 108.06 of the Standard Specifications.

107.1.7 Outdoor Advertising During Construction

For more detailed information on Outdoor Advertising, refer to 2 CCR 601-3, the Rules Governing Outdoor Advertising in Colorado. The contractor is required to follow all laws and regulations related to Outdoor Advertising.

Guidance on displaying contractor names and logos during construction. The contractor is permitted to display its name and/or logo on a construction project on equipment or materials visible to the public as long as the equipment or materials serves a construction function. For example, a stationary water tank or an equipment storage trailer that displays the contractor’s name and/or logo are permitted. An example of an item that is not allowed is a banner across a bridge or a fence that displays the company name and/or logo. In general, it is not allowed if the item it is not serving a construction purpose or if it is displayed with the purpose of advertising the contractor. Contact information such a phone number, email address, or website are not permitted. If you have any questions related to outdoor advertising, contact the Region Outdoor Advertising Administrator.

107.2 PERMITS, LICENSES, AND TAXES

If asked questions about Contractor tax liability or exemption certificates, CDOT personnel should:

1. provide reference to subsection 107.02 of the Standard Specifications;
2. refer questions regarding sales tax to the local taxing authority or the Sales, Use and Cigarette Tax Section of the Colorado Revenue Department; and
3. not state opinions or make decisions regarding tax liability, especially during project advertisement.

107.3 - 107.5 RESERVED

107.6 SANITARY, HEALTH, AND SAFETY PROVISIONS

107.6.1 Performance of Safety Critical Work

The following work elements are considered safety critical work:

1. Overhead girder erection
2. Overhead structure construction or repair
3. Removal of bridge
4. Removal of portion of bridge
5. Temporary works: false work, shoring that exceeds 5 feet in height, cofferdams, and temporary bridges
6. Work requiring the use of cranes or other lifting equipment
7. Blasting
8. Excavation and embankment adjacent to the roadway, especially if it requires shoring
9. Tunneling
10. Work operations such as pile driving and jack hammering which may create vibration and cause debris to fall into traffic.
11. Rock fall mitigation

The Contractor shall submit, for record purposes only, an initial detailed construction plan that addresses safe construction of each of the safety critical elements. When the specifications already require an erection plan or a bridge removal plan, it shall be included as a part of this plan. The detailed construction plan shall be submitted two weeks prior to the safety critical element conference described below. The construction plan shall be stamped “Approved for Construction” and signed by the Contractor. The construction plan will not be approved by the Engineer.

The Construction Plan shall include the following:

1. Safety Critical Element for which the plan is being prepared and submitted.
2. Contractor or subcontractor responsible for the plan preparation and the work.
3. Schedule, procedures, equipment, and sequence of operations, that comply with the working hour limitations
4. Temporary works required: false work, bracing, shoring, etc.

5. Additional actions that will be taken to ensure that the work will be performed safely.
6. Names and qualifications of workers who will be in responsible charge of the work:
 - a. Years of experience performing similar work
 - b. Training taken in performing similar work
 - c. Certifications earned in performing similar work
7. Names and qualifications of workers operating cranes or other lifting equipment
 - a. Years of experience performing similar work
 - b. Training taken in performing similar work
 - c. Certifications earned in performing similar work
8. The construction plan shall address how the Contractor will handle contingencies such as:
 - a. Unplanned events (storms, traffic accidents, etc.)
 - b. Structural elements that don't fit or line up
 - c. Work that cannot be completed in time for the roadway to be reopened to traffic
 - d. Replacement of workers who don't perform the work safely
 - e. Equipment failure
 - f. Other potential difficulties inherent in the type of work being performed
9. Name and qualifications of Contractor's person designated to determine and notify the Engineer in writing when it is safe to open a route to traffic after it has been closed for safety critical work.
10. Erection plan or bridge removal plan when submitted as required elsewhere by the specifications. Plan requirements that overlap with above requirements may be submitted only once.

A safety critical element conference shall be held two weeks prior to beginning construction on each safety critical element. The Engineer, the Contractor, the safety critical element subcontractors, and the Contractor's Engineer shall attend the conference. Required pre-erection conferences or bridge removal conferences may be included as a part of this conference.

After the safety critical element conference, and prior to beginning work on the safety critical element, the Contractor shall submit a final construction plan to the Engineer for record purposes only. The Contractor's Engineer shall sign, and seal temporary works related to construction plans for the safety critical elements, Removal of Portion of Bridge and Temporary

Works. The final construction plan shall be stamped “Approved for Construction” and signed by the Contractor.

The Contractor shall perform safety critical work only when the Engineer is on the project site. The Contractor’s Engineer shall be on site to inspect and provide written approval of safety critical work for which he provided stamped construction details. Unless otherwise directed or approved, the Contractor’s Engineer need not be on site during the actual performance of safety critical work but shall be present to conduct inspection for written approval of the safety critical work.

When ordered by the Engineer, the Contractor shall immediately stop safety critical work that is being performed in an unsafe manner or will result in an unsafe situation for the traveling public. Prior to stopping work, the Contractor shall make the situation safe for work stoppage. The Contractor shall submit an acceptable plan to correct the unsafe process before the Engineer will authorize resumption of the work.

When ordered by the Engineer, the Contractor shall remove workers from the project that are performing the safety critical work in a manner that creates an unsafe situation for the public in accordance with subsection 108.06 of the Standard Specifications.

Should an unplanned event occur, or the safety critical operation deviate from the submitted plan, the Contractor shall immediately cease operations on the safety critical element, except for performing any work necessary to ensure worksite safety, and provide proper protection of the work and the traveling public. If the Contractor intends to modify the submitted plan, he shall submit a revised plan to the Engineer prior to resuming operations.

All costs associated with the preparation and implementation of each safety critical element construction plan will not be measured and paid for separately but shall be included in the work.

Nothing in the section shall be construed to relieve the Contractor from ultimate liability for unsafe or negligent acts or to be a waiver of the Colorado Governmental Immunity Act on behalf of the Department.

107.6.2 Safety Equipment

Required personal protective equipment (including but not limited to hard hats, vests, eye protection, and foot protection) will be made available, and will be properly used by, all CDOT personnel and consultants pursuant to Procedural Directive 80.1, which is available at: <http://intranet/resources/policy-procedure/documents/0080-1/view>.

Consultants working on CDOT projects must wear the same personal protective equipment as CDOT personnel. Appropriate safety equipment will be used as required by the specific work conditions and current policy.

107.6.3 Responsibilities and Authority

The Contractor is responsible for complying with all safety, health and sanitation laws, rules, regulations, and guidelines, including but not limited to the Project Safety Management Plan (Plan) described in the specification, the Occupational Safety and Health Act (OSHA), 29 CFR 1910, 29 CFR 1926, 23 CFR 634, the Mine Safety and Health Administration (MSHA), Title 30 CFR, “Colorado Work Zone Best Practices Safety Guide”, CFR 49, national consensus standards, and the Federal Drug Free Workplace Act, and for ensuring the safety of all representatives and employees of the Contractor and all subcontractors, suppliers, Department personnel and consultants, visitors, and the public throughout the project site.

The specifications require the Contractor to prepare a project-specific safety management plan. The Contractor must certify that:

1. The Plan complies with applicable safety, health, and sanitation laws, rules, regulations, and guidelines.
2. All operations and work practices of the Contractor comply with it.
3. All subcontractors, suppliers, and Department personnel and consultants will comply with it.

The Contractor is to submit a copy of this Plan to the Engineer before starting work and is to keep it updated. The Engineer should be familiar with the specification and the Plan. The Engineer should review the Plan for general adequacy and compliance with the specification and notify the Contractor in writing that the plan has been received and addresses items 1 through 12 in the Standard Specifications. The Engineer may also request assistance from the Region Safety Officer.

An example project safety management plan has been posted on the Construction Specifications page of CDOT's website. Notice that this is only an example project safety management plan. It may be used only as a guide in preparing an actual project safety management plan. The safety management plan for a particular project must address the project specific construction activities. The URL for the CDOT web page on which the example plan may be found is:

<http://www.coloradodot.info/business/designsupport/construction-specifications/2011Specs>.

Among other things, the specification requires at a minimum that all personnel on the project site are to wear hard hats, high visibility apparel and appropriate, sturdy footwear at all times when outside of their vehicles and within CDOT ROW. Consider the following additional guidelines:

1. CDOT Responsibility and Authority. The Department will not permit any employee to work in or around unsanitary or unsafe conditions. All CDOT and Consultant personnel on the project should monitor Contractor and subcontractor activities for obvious or suspected noncompliance with the Plan, and safety, health and sanitation laws, rules, regulations, and guidelines. Any concerns should be raised immediately and followed up in writing with the Contractor's competent person for that activity, the Superintendent, or the Contractor's Project Safety Manager. Due to training and liability constraints, the

Department does not have the authority to accept a specific condition as complying with OSHA requirements. Furthermore, it is not the intent of the specification for CDOT or Consultant personnel to function as OSHA enforcement or OSHA inspectors. The Contractor is responsible for compliance with its Plan.

2. **Noncompliance.** The Project Engineer will immediately notify the Contractor in writing of apparent noncompliance with the Plan, or other laws, rules, and regulations. The specification requires the Contractor to respond in writing to safety issues raised by the Engineer. The Engineer may contact the Region Safety Officer or the Statewide Safety Manager for assistance.
3. **Imminent Danger.** Imminent danger as defined by OSHA is any condition or practices in any place of employment which are such that a danger exists which could reasonably be expected to cause death or serious physical harm immediately or before the imminence of such danger can be eliminated through the enforcement procedures otherwise provided by this Act. It should be noted that subsection 105.01 of the Standard Specifications requires the Engineer to suspend immediately all or part of the work when the Contractor fails to correct conditions unsafe for the workers or the general public. Additionally, the Project Safety Planning special provision now allows the Engineer to immediately enact a “safety stand-down” in the case of an accident (including property damage), or catastrophe (the hospitalization of three or more employees, resulting from a work-related incident or exposure; in general, from an accident or an illness caused by a workplace hazard), or other situation presenting an imminent danger to life or health, such as a “near miss”, violation of the Plan, or presence of a hazardous situation. The safety stand-down is mandatory in the case of a work zone fatality directly related to the Contractor’s or any subcontractor’s operations. The Engineer will need to apply judgment in non-fatal situations, in cases of vehicular fatality not caused by a work zone incident, and for minor infractions. The Contractor is required to provide properly certified documentation specifying the corrective measures that it has taken to prevent recurrence before the Contractor may resume operations. Contact the Region Safety Officer or the Statewide Safety Manager for assistance with questionable situations and for review of the Contractor’s corrective measures.
4. **Notification for Serious Accident or Event on Construction Projects.** Notification shall be given to the Region Safety Officer (RSO), and the instruction followed in the most current version of “Notification for Serious Accident or Event,” anytime there is a serious accident or event on a construction project. This includes any fatalities on a construction project. The Project Engineer will provide any requested documentation to the RSO. The most current version of “Notification for Serious Accident or Event” may be found at: <http://intranet.dot.state.co.us/best-dot/risk-management>.

The Engineer should withhold progress payments, suspend the project, or both, for failure to submit an acceptable Plan or update it, for failure to respond in writing to safety issues that are raised by the Engineer, or for failure to submit documentation of safety inspections.

107.7 - 107.9 RESERVED

107.10 BARRICADES AND SIGNS

The provisions of the Manual on Uniform Traffic Control Devices for Streets and Highways (MUTCD) and the CDOT Supplement to the MUTCD govern the work zone traffic control that will be used on CDOT construction projects. A change order is required before major changes can be made to the Traffic Control Plan for any project. For additional information on work zone traffic control, see Section 630 of this Manual and Section 630 of the Standard Specifications.

107.11 RESERVED

107.12 PROTECTION AND RESTORATION OF PROPERTY AND LANDSCAPE

Many construction projects have environmental mitigation commitments. These commitments were developed in the project development process as part of the National Environmental Policy Act. These commitments may be in the form of water quality permit requirements, wetland mitigation, endangered species mitigation, cultural resources mitigation or others.

It is the Project Engineer's responsibility to ensure compliance with the environmental mitigation commitments during construction. Violations of environmental regulations can result in civil and criminal penalties.

Recommendations:

1. Project Engineers should review the plans and the environmental mitigation commitments and discuss them with the RPEM before the project is advertised to ensure all commitments are addressed and understood.
2. At the Environmental Preconstruction Conference, ensure all sub-contractors have been invited and be sure to cover the environmental requirements. Request that the RPEM or other environmental specialist attend to speak to the environmental issues.
3. At weekly meetings with the Contractor and subcontractors, be sure to cover the environmental mitigation commitments.
4. If you suspect you will have difficulty getting the Contractor to comply with certain requirements, ask for assistance from your RPEM.

107.13 FOREST PROTECTION

107.13.1 Preservation of Wetland Areas and Plant and Animal Habitats

Legally protected wetland areas and habitats of threatened and endangered species will be designated in the Contract. As needed, contact CDOT Natural Resources Staff in Environmental Programs for assistance regarding permits or special treatments. Ensure that the Contractor

has been properly informed regarding the importance of preserving wetland areas and plant and animal habitats. Check that limits of encroachment are clearly marked before construction begins. For affected projects, the requirements stipulated in the permits must be reviewed and understood by all project personnel.

There are three project special provisions that may appear in the Contract to implement Migratory Bird Treaty Act requirements:

1. One for use on projects where the work consists only of structure work.
2. One for use on projects where the work includes soil and vegetation disturbance and bird surveys have been done by CDOT environmental personnel.
3. One for use on projects where the work includes soil and vegetation disturbance, and bird surveys will be done by the Contractor's wildlife biologist.

The appropriate one of these special provisions will be included in the Contract for each project. The RPEM and the Staff Biologist are responsible for working with engineers to prevent potential problems and for collaborating on avoidance and mitigation measures.

CDOT staff involved in construction will act to ensure that appropriate and reasonable measures are taken to prevent the taking of migratory birds.

107.13.2 Preservation of Trees and Shrubs

Trees and shrubs are protected for both environmental and aesthetic purposes. Before construction, check to ensure that protected trees and shrubs are clearly marked for preservation, and ensure that the Contractor fully understands the limits within which clearing and grubbing may be performed.

107.14 RESERVED

107.15 RESPONSIBILITY FOR DAMAGE CLAIMS, INSURANCE TYPES AND COVERAGE LIMITS

Subsection 107.15 of the Standard Specifications requires the Contractor to procure and maintain public liability and property damage insurance. The Project Engineer shall review the certificate of insurance to ensure it meets the requirements of Subsection 107.15 of the Standard Specifications. Insurance coverage is evidenced by a Certificate of Insurance, which certifies that the policy is in effect and will not be canceled without CDOT receiving written notice 30 days prior to cancellation. The Contractor must forward Certificates of Insurance for the required coverage to the Construction Engineering Services Branch before the Contract will be executed.

The Project Engineer will monitor cancellations of the insurance coverage. If coverage expires, the Project Engineer, with the approval of the Resident Engineer, will issue a written stop work

order to the Contractor, and work must not resume until the Contractor furnishes a new Certificate of Insurance.

107.16 OPENING SECTIONS OF PROJECT TO TRAFFIC

The Contract will define the criteria for opening sections of the project to traffic, and subsection 107.16 of the Standard Specifications gives the Project Engineer authority to order the openings. Consider the following:

1. **Contractor Delay.** If it is necessary to order the opening of a section to traffic because the Contractor caused a delay in completing the work, the Contractor shall be responsible for all costs until final project acceptance, including the costs for damage caused by traffic.
2. **Other Basis.** If it is necessary to order the opening of a section of the project to traffic and the order is not based on Contractor delay, the Contractor is not responsible for damage caused by traffic. A change order must be executed to compensate the Contractor for associated delays and additional costs.

107.17 CONTRACTOR'S RESPONSIBILITY FOR WORK

Subsection 107.17 of the Standard Specifications defines the provisions by which the Project Engineer may relieve the Contractor of expenses for restoring damage to contract work caused by traffic and other elements. Consider the following guidelines:

1. **Expense Relief Granted.** If damage occurs to work on sections of the project where the Contractor has been granted relief from restoration expenses, the following two restoration options are acceptable:
 - a. Require the Contractor to repair the work and pay for the restoration under the provisions of subsection 104.03 of the Standard Specifications.
 - b. Contact the Region Maintenance Superintendent to schedule the needed restoration work.
2. **Expense Relief Not Granted.** If damage occurs to work on sections of the project where the Contractor has not been granted relief from restoration expenses, the Project Engineer must determine what, if any, of the restoration expenses are attributable to the Contractor. This depends primarily on the extent to which the Contractor provided protection from a foreseeable cause of damage. In general, if the work was damaged by an unforeseeable cause, the Department will pay for restoration expenses. Consider the following guidelines:
 - a. **Unforeseeable Causes.** Unforeseeable causes of damage are causes beyond the control of the Contractor that could not have been reasonably anticipated. For example, 100 mile per hour winds can cause major damage to a project. If the occurrence was deemed rare and unlikely, as demonstrated by historical weather data for the location and time of year, the costs for restoration should generally be borne by the Department.

- b. **Foreseeable Causes.** Foreseeable causes of damage are causes that can be reasonably anticipated by the Contractor, whether they are in the Contractor's control. For example, 100 mile per hour winds in the Boulder area are generally predictable from year to year based on the season. If such winds caused damage to a project in the Boulder area and the Contractor did not provide adequate and reasonable protection from this foreseeable event, restoration costs should be borne by the Contractor.
- c. **Traffic.** The cost of restoring damage to work caused by traffic is generally borne by the Contractor, because CDOT considers traffic a foreseeable cause of damage. However, there are instances where the restoration costs should be borne by the Department. The following examples are provided to clarify this policy:
 - i. The project is a HMA overlay. The traveling public damages a section of existing guardrail. The Department will pay for restoration of the damaged guardrail.
 - ii. The project is a partial reconstruction that includes guardrail removal and replacement. The traveling public damages a section of newly installed guardrail. The Contractor shall pay for the restoration of the damaged guardrail.
 - iii. The project is a HMA overlay. A Contractor supplier damages a section of bridge rail. The Contractor shall pay for the restoration of the damaged bridge rail.

107.18 - 107.22 RESERVED

107.23 ARCHAEOLOGICAL AND PALEONTOLOGICAL DISCOVERIES

107.23.1 Site Investigation

Ensure that the Contractor has been properly informed regarding the importance of preserving protected archaeological and paleontological sites. Protected sites should be clearly marked before construction begins.

107.23.2 Discovery During Construction

If archaeological or paleontological resources such as plant or animal fossils remains, chipped stone, pottery shards, purple bottle glass, or suspected human skeletal remains are encountered during construction, halt all activity that would otherwise disturb the discovery and immediately notify the CDOT Cultural Resources Staff (e.g., Staff Archaeologist or Paleontologist) in Environmental Programs of the Department of Transportation Development (DTD). CDOT Cultural Resources Staff will provide recommendations. Do not restart construction until directed to do so by the CDOT Cultural Resources Staff.

107.24 RESERVED

107.25 WATER QUALITY CONTROL

107.25.1 General

The following Section presents an overview of Federal and State requirements for water quality control within the State of Colorado. For further information, see the CDOT Erosion Control and Storm Water Quality Guide, and subsection 107.25 and Section 208 of the Standard Special Provisions for projects less than one acre, and subsection 107.25 and Section 208 of the Standard Specifications for projects equal to or greater than one acre, as referenced below.

107.25.2 Contractor Responsibility

The Contractor shall comply with all governing Federal, State and local water quality control regulations, permit requirements, and all Contract requirements associated with temporary and permanent water pollution control measures for streams, side ditches, lakes, ponds, and other watercourses (State waters). With permission from and at the direction of the Engineer, the Contractor shall comply with action items documented by the Region or Headquarters inspections. For projects over an acre, the Contractor faces enforcement action by the Colorado Department of Public Health and Environment for permit violations and liquidated damages from CDOT under subsection 208.09 - Regulatory Mechanism for Water Quality. Where concrete washout sites will be used, they must be pre-approved by the Engineer. See the CDOT Erosion Control and Storm Water Quality Guide and Section 208 of the Standard Special Provision for projects under one acre, and Section 208 of the Standard Specifications for projects equal to or greater than one acre.

107.25.2.1 SWMP

The Contractor must maintain a Storm water Management Plan (SWMP).

See Section 208.03(d) 1 of the Standard Special Provision for projects less than one acre, and Section 208.03(d) 1 of the Standard Specifications for projects equal to or greater than one acre, for a list of required SWMP contents. The SWMP is property of CDOT and shall be available for reference at the CDOT field office during construction. Upon final acceptance, for sites equal to or greater than one acre, the Engineer will provide the SWMP to the Region Water Pollution Control Manager (RWPCM). Upon final acceptance for sites with less than one acre of disturbed area (no Colorado Discharge Permit System Stormwater Construction Permit), the SWMP shall be provided to the Finals Administrator.

107.25.2.2 Environmental Preconstruction Assessment

Prior to the Environmental Preconstruction Conference, the Contractor's SWMP Administrator shall provide a list that identifies and describes all potential pollutant sources. At, or prior to, the Environmental Preconstruction Conference, the Contractor shall submit a Spill Response Plan (SRP) in accordance with subsection 107.25(b) of the Standard Special Provision for projects less than one acre, and subsection 107.25(b)5 of the Standard Specifications for

projects greater than or equal to one acre. See subsection 208.06(c) in Standard Special Provisions for projects under one acre, and 208.06(c) of the Standard Specifications for projects equal to or greater than one acre, for the required contents of the SRP. Work shall not be started until the plan has been submitted to and approved by the Engineer.

A minimum of ten days prior to the start of the construction activity, the Contractor shall submit in writing a Method Statement for Containing Pollutant Byproducts to the Engineer for approval. For requirements, see subsection 107.25(b) in the appropriate Standard Special Provision for projects less than one acre, and subsection 107.25(b)12 of the Standard Specifications for projects greater than or equal to one acre (CDOT or Contractor Obtained Stormwater Permit).

A Spill Prevention, Control and Countermeasure Plan (SPCC) may be required from the Contractor prior to the start of work. See subsection 107.25(b) of the appropriate Standard Special Provision for projects less than one acre, and subsection 107.25(b)5 of the Standard Specifications for projects greater than or equal to one acre (CDOT or Contractor Obtained Stormwater Permit) for SPCC requirement criteria.

For projects over one acre of disturbance, invite the Region Water Pollution Control Manager (RWPCM) to the Environmental Preconstruction Meeting.

107.25.2.3 Site Cleanliness

The Contractor shall certify that construction equipment has been cleaned prior to site arrival. Vehicles shall be free of soil and debris capable of transporting noxious weed seeds or roots onto the site.

At the end of each day, the Contractor shall collect all trash and dispose of it in appropriate containers. Containers shall be emptied as needed.

107.25.3 Internal CDOT Coordination

Because of the different Contract requirements of who is responsible to obtain the required environmental permits and who is the permittee/s of record, internal CDOT coordination is essential. Notification from Federal, State, and local regulatory agencies of pending inspections or Notice Of Violation must immediately be communicated between the HQ Environmental Programs Branch, region environmental staff, Project Engineer and Resident Engineer.

107.25.4 Permit and Reporting Requirements

To meet the Environmental Protection Agency's stormwater quality regulations (i.e., National Pollution Discharge Elimination System), the Colorado Department of Public Health and Environment enforces the Colorado Discharge Permit System. All construction activities, except those disturbing less than one acre of total land area that are not part of a larger common plan, must comply with these requirements. EPA remains the permitting authority for projects located on Federal or Tribal lands.

The Colorado Department of Public Health and Environment must issue a general permit, entitled, “CDPS General Permit for Stormwater Discharges Associated with Construction Activity” (CDPS-SCP). There are also “Qualified Local Agencies”, that have been designated by CDPHE to issue stormwater permits up to 5 acres. Some local agency stormwater requirements may need to be adhered to and that the Regional Environmental Unit should be consulted.

If the Standard Specification 107.25 has been included in the Contract, CDOT is responsible for obtaining the CDPS-SCP permit prior to advertisement. The Contractor and CDOT will be co-permittees before the start of any construction. The Contractor will provide proof that they are a permittee on required permits prior to start of construction. If a project special 107.25 has been included in the contract, refer to the terms of the project special.

When a Utility Company has obtained a CDPS-SCP within a CDOT project area, prior to the Contractor being on-site, the Contractor shall coordinate with the Engineer and the Utility Company to transfer or reassign the permit area within the project’s Limits of Construction to the Contractor and CDOT prior to work commencing. The Contractor shall not commence construction until CDPHE issues a new CDPS-SCP identifying the Contractor as the Operator, and the permit is put in the SWMP 107.25(c).

The Erosion Control Management (ECM) staff consists of a SWMP Administrator and one or more Erosion Control Inspectors, if required, depending on the overall area of disturbed area. See subsection 208.03(c) in the Standard Specifications, or 208.03(c) of the Standard Special Provision, for additional information on the duties and requirements for ECM staff.

The Contractor shall be responsible for obtaining permits for construction groundwater dewatering unless already obtained by CDOT. The Contractor is again solely responsible for compliance with this permit, and if CDOT obtained the permit, the Contractor shall contact the Colorado Department of Public Health and Environment and accept responsibility for the permit. Construction Dewatering may be discharged to the ground on projects where CDPHE’s Low Risk Guidance Document for Discharges of Uncontaminated Groundwater to Land are met (107.25(b)8).

If a spill occurs on site, the Contractor shall immediately implement the SRP.

107.25.4.1 Transfer of Stormwater Permit from the Contractor to CDOT Maintenance

As the project nears completion, the Contractor shall request a review of the erosion control site conditions and documentation (Partial Acceptance of permanent stabilization unit of work). The timing of this review will be when, at the judgement of the Engineer, the project is sufficiently completed as that no further construction operations will affect permit requirements, but sufficient Contractor equipment and workforce remains to do the “punch list” type work on erosion control features. See subsection 107.25(d) of the Standard Specifications (CDOT or Contractor Obtained Stormwater Permit) for requirements. In design build the Contractor may be contracted until final stabilization is achieved (70% of pre disturbance vegetation). In some Regions the permit is transferred to CDOT Maintenance and

other Regions to a CDOT Engineer that is overseeing a Post Construction Establishment Phase (PCEP) Contractor; please make plans according to the Regions and project needs.

107.25.5 Waste Disposal Practices

Before construction, ensure that the Contractor fully understands the contractual and legal obligations regarding waste disposal, and verify the proposed disposal methods and sites for compliance. Consider the following guidelines:

1. **Legal and Safety Considerations.** The Contractor is responsible for complying with all applicable Federal and State laws and safety regulations and any applicable local ordinances with respect to waste disposal and burning of debris, as governed by Section 107 and Section 250 of the Standard Specifications.
2. **Burning.** Burning of debris, without written approval from the Project Engineer, will not be permitted. If approved, verify that the Contractor is performing the operation as specified.
3. **Temporary On-Site Storage and Containment.** A suitable and properly prepared on-site location should be used to temporarily store and contain waste and debris until it can be hauled to a suitable disposal site. Factors that should be considered include waste composition, location, number of containers, lids, coverings, and drainage. If the Contractor uses a site on private property, written permission from the landowner is required and the Contractor shall provide the Project Engineer with a copy (see Section 200).
4. **Hazardous Waste.** Known and discovered hazardous waste on the project requires special treatment. See Section 250 for additional information.

107.25.6 Spill Prevention Practices

Spill prevention practices are generally specified on projects where chemicals and hazardous substances will be used. Refer to the Erosion Control and Storm Water Quality Guide.

SECTION 108 PROSECUTION AND PROGRESS

Section 108 of the Standard Specifications governs the prosecution and progress of the work performed by the Contractor.

108.1 SUBLETTING OF CONTRACT

Subsection 108.01 of the Standard Specifications requires the Contractor to perform a minimum of 30 percent of the Contract work with its own forces, excluding specialty items. Cost of materials and manufactured products to be purchased or produced by the Contractor may be included in the original contract amount. Prior to subcontracting any work on the project, the Contractor must submit Form 205 - Sublet Permit Application to the Project Engineer for signature approval.

See Section 120.10 of this Manual for additional information.

108.2 NOTICE TO PROCEED

The Contractor shall not initiate work on the Contract prior to receiving the written Notice to Proceed. The Award Officer in the Engineering Contracts unit issues the Notice to Proceed (NTP) to the Contractor once the contract is fully executed. A PDF copy of the NTP or a link to a copy in ProjectWise® is posted in SAP in the Purchase Order (PO) as an attachment. Use transaction ME23N- Display Purchase Order if you know the PO number or ME2J - Purchase Order for Project if you have the subaccount (project definition or project code).

1. ME23N - Display Purchase Order

Usually, the last PO opened will display, if this is not the PO for the Project you are looking for, click on the Other Purchase Order button. In the Select Document dialog box, enter the correct PO number in the Purchase Order field and click on the Other Document button. Once the PO is opened click on the Services for Object button then select Attachment List. If the NTP is available, it is in the list, double click the file or link and open the PDF file.

2. ME2J - Purchase Order for Project

Enter the five-digit Project Definition (subaccount) in the Project field and click Execute. A list of Purchase Orders (PO) related to the project will display. Scroll to the PO with the Order type ZG - Highway Construction and double click that row. The PO will open in a new window. Click on the Services for Object button then select Attachment List. If the NTP is available in the list, double click the file or link and open the PDF file.

108.3 SCHEDULE

Subsection 108.03 of the Standard Special Provision, Revision of Section 108 - Project Schedule requires the Contractor to submit a Microsoft Project or Primavera Critical Path Method (CPM) project schedule. The Engineer is required to approve the Preliminary or Baseline Schedule before work may start. Bar charts are not an acceptable option. It is essential to ensure that schedule submittal packages include all of the information and reports listed in subsection 108.03(c) Schedule Submittals of the Standard Special Provision, Revision of Section 108 - Project Schedule. The Engineer is required to retain the electronic files in native file format (*.mpp for Microsoft Project schedules or *.xer for Primavera schedules) and all reports in Portable Document Format (PDF) for every schedule submittal. The schedule submittal, narrative, and reports are necessary for analyzing the planned work, progress of the work, changes, and delays. The PDF documents are intended to provide a snapshot of the schedule that cannot be changed. In this guidance, when referring to an approved schedule, the status of the schedule is either “Approved, no exceptions taken” or “Approved-as-noted” and a complete schedule submittal includes the native file, the Job Progress Narrative, and all reports.

CPM schedules are essential for planning and managing the project. The purposes of the schedules are to:

- demonstrate the Contractor’s plan for executing the work;
- be a reflection of the actual work started, progressed, or completed;
- serve as a communication tool with stakeholders;
- manage CDOT and Contractor resources;
- determine impacts from time-related changes; and
- ensure the critical path is agreeable and logical to all parties.

The intent of the schedule submittal requirement is to empower CDOT and the Contractor to proactively manage project issues rather than reacting to issues. An additional benefit of this requirement is that a schedule analysis is favorable and allows for delay issues to be resolved quickly. In order for CPM schedules to be useful, the Preliminary Schedule, Baseline Schedule, Project Schedule Updates, and Revised Schedule must be reasonable, accurate, and the contemporaneous schedule must be updated and maintained in accordance with the specifications.

108.3.1 Reviewing the Schedule

The Engineer will review all Preliminary, Baseline, Project Schedule Update, and Revised Schedule submittals including all reports and will provide the Contractor with a written response based on the review within 10 days of receiving the complete submittal. If the Engineer approves a schedule in which the Contractor does not include an element of work, that contains insufficient or incomplete logic, or that contains errors, this will not excuse the

Contractor from completing all the work within the contract or within contract time. The Department will only change a contract by issuing a change order. The intent of the review of the schedule is to understand the Contractor's plan for completing the work and to ensure it reflects the contract requirements. Schedule development and project execution is the Contractor's responsibility; however, the Engineer has a responsibility to verify that the work is logically organized and check whether the times allotted to activity durations appear adequate. The Engineer should not feel obligated to "catch" everything. During the review, it is important to discuss with the Contractor and document observed issues and inconsistencies between daily diaries, actual events, and events being shown in the schedule. The Engineer is also cautioned to take care not to direct the Contractor's means and methods.

As a project progresses from start to finish, the Contractor is required to submit the schedules listed in subsection 108.03(d) through (i) of the Standard Special Provision, Revision of Section 108 - Project Schedule as appropriate. Below are some considerations for reviewing each of these schedules.

1. Reviewing the Schedule Submittal for Completeness

The reviewer first should ensure that schedule submittals are complete. Does the submittal include all the required components, including the native file and reports in the correct format? If a submittal is not complete, the Engineer should immediately notify the Contractor and request the missing information. The Engineer may request this verbally if it is a minor oversight and consider requesting in the additional information in writing when it is a greater concern. If the Contractor does not respond timely (consider about two business days), the Engineer should notify the Contractor in writing on a Form 105 to "Revise and Resubmit", explaining why the submittal is incomplete and that the review cannot continue until the submittal is complete. The Engineer should identify which items are missing and not allow work to start or withhold payments until a complete package is received. To help ensure that a schedule submittal is complete, see CPM Schedule Review Checklist 1 - Schedule Submittal (Appendix B). The best response to each item in the checklist is "yes".

Next, the reviewer will analyze the schedule to make sure that it is reasonable. When performing the review, the entire CDOT project team should participate and be engaged.

2. Conducting the Schedule Review Meeting

A Schedule Review meeting should be held following each submission of a Preliminary, Baseline, Project Schedule Update, or Revised Schedule. The CDOT Project Engineer, the CDOT schedule consultant (if applicable), the Contractor's project manager or superintendent, the individual that developed the Contractor's schedule, key subcontractors, and any other key project personnel should participate in the Schedule Review meeting. To help manage the schedule review efficiently, it is recommended that the meetings focus on the review and approval of the Schedule and not include other topics. The Schedule Review meeting is useful to discuss items that are either going well or not going as planned. For items that are not going as planned, discussion should include possible mitigation measures that all parties could undertake to improve the situation.

The purpose of the meeting is to:

- validate that CDOT and the Contractor have a similar understanding of critical issues and actual/potential schedule risks;
- discuss the Contractor's approach and sequence to construct the job;
- discuss questions or discrepancies in the schedule to resolve issues and minimize revisions and resubmissions;
- establish an open line of communication about the schedule.

Timing for the meeting should be as soon as feasible after receipt of a complete schedule submittal and with enough time to allow the Engineer to respond within 10 days of submission of the complete schedule. In advance of the meeting, the Engineer and the CDOT schedule consultant (if applicable) will conduct an in-depth review to assist in development of the meeting agenda and focus areas. The Engineer may share these comments with the Contractor in advance of the meeting. Together, the Contractor and the Engineer will determine who will attend the meeting, who will facilitate the meeting, and the agenda for the meeting. If possible, and to expedite a response, consider editing the schedule and narrative during the meeting.

An agenda for Preliminary, Baseline, and Revised Schedule Review meeting may include:

- Introductions (All)
- CDOT will review the Project Scope
- Contractor discussion of the:
- Approach to the Work
- Critical and Near Critical paths with risks and assumptions
- Planned workdays and hours, non-work periods including weather days included in the schedule, calendars, and their applicability
- Planned completion date and how it fits with contract time
- [Preliminary] The Contractor's plans and timing to develop and submit the Baseline Schedule
- [Revised] Added, modified, and deleted activities, logic changes and duration changes, and critical and near critical path changes with explanations

Engineer discussion of items that:

- Require revision before work may begin
- Are "Approved-as-noted" and require attention before next submittal is approved
- Are "Approved-as-noted" and only informational

- Develop next steps to resolve open items

An agenda for Project Schedule Update Schedule Review meeting may include:

- Introductions (All)
- Contractor discussion of the:
 - All the work performed
 - Status of critical and near critical pending items
 - Changes to the planned worked or problems encountered
 - Explanations for milestones, critical and near critical activities not progressing as planned
 - Completion date status and if necessary for change
 - Current and anticipated delays including effect on work and critical path and actions needed or taken to avoid and mitigate delay
 - For working day contracts, discuss the planned non-working days with actual work.
 - Added, modified, and deleted activities, logic changes and duration changes, and critical and near critical path changes with explanations for change

Engineer discussion of items that:

- Require revision before work may begin
- Are “Approved-as-noted” and require attention before next submittal is approved
- Are “Approved-as-noted” and only informational
- Develop next steps to resolve open items

Example of a Successful Baseline Schedule Review:

A Contractor was awarded a mountain corridor project. The scope of the project is fixing flooding damage. Safety improvements were also made, including widened shoulders, guardrails, and improved sight distances. A multi-use trail was also improved as part of the project. The contract was a working day contract, with the overall duration planned over two construction seasons.

When the Contractor submitted the Baseline Schedule the team had a number of comments. It was observed that planned weather days and seasonal restrictions for paving were not accounted for in the project calendars. During the Baseline Review meeting, these items were discussed. Initially the Contractor thought this would be a minimal impact. However, after

incorporating the no-work periods into the project calendars, the schedule showed, the work was going to take three seasons and be a year late! Identifying these risks early in the project allows the project team time for mitigation and resequencing in order to get the project back on track.

Realizing major scheduling issues up front provides the best opportunity to make adjustments that will result in a successful project. With each passing month, the ability to address schedule concerns becomes more difficult, with new unplanned issues continuously arising. Oftentimes a single issue might not be considered a major schedule risk, but when multiple issues are incorporated into the schedule the compounding effect changes the approach for the project.

Note that the Schedule Review meeting and Job Progress Narrative are not intended to qualify as notice of a delay event. If the Contractor seems to be describing a delay event, the discussion should focus on actions required by all parties to mitigate a delay event, as opposed to validation of a delay event. The Engineer will direct the Contractor to follow the time extension process. If a time extension is required, the Contractor shall submit a written request for an Extension of Contract Time per subsection 108.08(d) of the Standard Specifications.

3. Reviewing the Preliminary or Baseline Schedule

The Preliminary and Baseline Schedules are necessary because they serve as benchmarks for subsequent schedule submittals. These schedules will have no progress and will show all work completed within the contract time. The Contractor may choose to submit either a Preliminary Schedule and a Baseline Schedule (see A.) or only a Baseline Schedule (see B). If no schedule is submitted and the Engineer has not approved a Preliminary or Baseline Schedule, work will not begin. The first submittal is due within 14 days of Award and before Notice to Proceed is issued. If the submittal is received at this time, the Engineer and Contractor have approximately 30 days available to hold a Schedule Review meeting, resolve comments, and respond with approval, before the work is allowed to start. Subsection 108.02 allows 30 days for the execution of the contract and issuance of the Notice to Proceed.

- a. Preliminary Schedule Submittal - When the project is complex or expected to span multiple construction seasons, the Contractor may choose to submit a Preliminary Schedule followed by a Baseline Schedule, allowing the work to begin sooner, and providing the Contractor more time to develop a complete Baseline Schedule. The Preliminary Schedule will show the details for the planned activities to take place in the first 60 working days of the project and include a summary of activities through planned completion. The detail required for the remainder of the project duration should include summary tasks by phase or work type. The Engineer will focus the review on the first 60 days using the Checklist 2 - Preliminary and Baseline Schedule Checklist. The review of the information after the first 60 working days may be at a cursory level and will focus on determining if the details of the Preliminary Schedule are reasonable and the logic makes sense. A detailed review of the remaining activities occurs when reviewing the complete Baseline Schedule.

When a Preliminary Schedule is submitted, a Baseline Schedule is required by the 45th day after Award. This will typically be a short time after Notice to Proceed

and the work is likely to have begun (this could be as early as 15 days after work starts). The Baseline Schedule submitted after a Preliminary Schedule will contain all the details of the Preliminary Schedule and include additional details for the remaining portions of the work. Review of the Baseline is described below. If the Baseline Schedule is not received within 45 days after the contract Award, the Engineer will withhold payments until a schedule is received. Within the first 60 days, the Engineer will not process payments until a complete Baseline Schedule is submitted. The Engineer will not allow work to continue past the first 60 days and will not make payments until a complete Baseline Schedule is approved.

- b. Baseline Schedule Submittal - When the Contractor submits a Baseline Schedule, the review will focus on determining if all the details of the schedule are reasonable and the logic makes sense. Once the Baseline Schedule is approved; the Engineer may request the Contractor to set the baseline in the native file before beginning to show progress in the schedule. Until the Baseline Schedule is approved, the Contractor should not show progress in the Schedule.

The Engineer should check the schedule to see if:

- all contract work has been addressed.
- durations are realistic.
- production rates are reasonable.

Checklist 2 - Preliminary and Baseline Schedule (Appendix B) will help determine topics for the Schedule Review meeting and the items the Contractor needs to address. It is possible that some of the items listed will not apply to every project. The best response to each item in the checklist is “yes”. If a statement applies and you cannot answer yes, decide if you should approve or require corrections and resubmit.

4. Reviewing the Project Schedule Update

The Project Schedule Update should include all actual work completed up to, but not including the cut-off date for the monthly progress pay estimate; this will be the Data Date in the schedule. Checklist 3 - Project Schedule Update Checklist (Appendix B) provides a list of items to review. If any of the items in Checklist 3 are found in the Project Schedule Update, they also should be discussed in the Job Progress Narrative and discussed at the Schedule Review meeting.

As the project progresses and regardless of the Contract Time, the Planned Completion Date on the final activity may vary in the update. When a Project Schedule Update has a completion date later than the contract completion date and is approved, such approval does not change the contract requirement to complete the work on time. Only a change order can change the contract completion date. When there is a substantial variation in milestone dates or the completion date, the Job Progress Narrative should address the Contractor’s plan for completing the work on time. The Job Progress Narrative and Schedule Review meeting are not intended to qualify as notice of a delay event. When the Contractor describes a delay, the discussion should focus on actions required by all

parties to mitigate a delay, as opposed to validation of a delay. The Engineer will direct the Contractor to follow the Request for Extension of Contract Time process. If a time extension is required, the Contractor shall submit a written request for an Extension of Contract Time per subsection 108.08(d) of the Standard Specifications.

When reviewing a Project Schedule Update, focus on the critical and near critical activities. Evaluate the work planned versus what was accomplished, by comparing the planned start and finish dates, durations to the Update's actual start, actual finish, actual duration, and actual percent complete of activities. Verify this with field staff and daily diaries. Evaluate if there were activities that may have had progress, but none reported. A failure to report progress on activities can significantly influence float calculations.

Evaluate any work that did not start when planned and when non-critical work was not performed when planned or was performed out of sequence. Also consider the impact to the Contractor's resources; when similar work is stacking, evaluate if the Contractor has adequate resources to complete this work. This should not interfere with activities that are CDOT's responsibility. For example, if CDOT has a review period of 10 days, the schedule should also allow for 10 days. When non-critical work has experienced significant slippage or has been performed out of sequence, the Contractor is expected to explain the reasoning.

With a good Baseline Schedule, if no significant scope or work changes were encountered during the month, there should be minimal changes to the schedule activities, original durations, logic, and critical path. If significant changes are made to activities, durations, logic, or the critical path, refer to the Reviewing the Revised Schedule section. The Job Progress Narrative should clearly explain the need for changes to the schedule. When the Contractor makes changes to original durations, carefully review that the submittal reflects the actual plan to complete the work. Look for changed, added, or removed activities on the critical path. Focus the review on these items to determine if the changes are reasonable. Analyze the reasoning for the changes and evaluate if they are made in an effort to hide or minimize a known delay or other event.

The Job Progress Narrative should include a discussion of the past months and upcoming month's work. The Engineer should also review these items with the Weekly Planning Schedule. The Project Schedule Update, Job Progress Narrative, and Weekly Planning Schedule should align with each other.

Note that Microsoft Project will automatically add a constraint on incomplete work and may show an early finish date completion in the past. This is a flaw with Microsoft Project and needs to be evaluated during the schedule review. Microsoft Project allows progressing of the schedule so that an incomplete activity's early finish date is calculated based upon remaining duration without taking into consideration the data date. This happens when the planned duration would have the activity completed before the data date and the actual duration spans past the data date. This must be corrected to reflect the actual start and actual planned duration and when the activity is complete the actual finish date. Work in progress that has not been completed cannot show an early finish date in the past.

Often, work will have occurred in the period of time between the submittal of the Project Schedule Update and the review and approval of the schedule. When reviewing the

schedule, the Engineer should keep in mind the progress made during this time or work that occurs differently than originally planned. Keep in mind the schedule is a snapshot in time and the focus should be on the plan to complete the work.

Checklist 3 - Project Schedule Update (Appendix B) will help determine topics for the Schedule Review meeting and the items the Contractor needs to address. It is possible that some of the items listed will not apply to every project. The best response to each item in the checklist is "Yes". If statement applies, and you cannot answer "yes," decide if you should respond Approve-as-noted, require Revise and resubmit, or require a Revised Schedule.

5. Reviewing the Weekly Planning Schedule

The Weekly Planning Schedule (WPS) shows the Contractor's and all subcontractor's planned activities for a minimum of the upcoming two weeks and a summary of the actual work performed for the previous week. This information should be used in comparing the previous WPS and the current Project Schedule Update. This schedule is typically detailed at the activity level and shall include the description, responsible party, duration and sequence of work activities, and anticipated lane closures to allow for the planning of upcoming activities. Ideally, the WPS should be an extraction from the Project Schedule and based on a CPM analysis. The Engineer may accept a time-scaled logic bar chart or other standard format. The WPS does not require the reports or native file submittal requirements and it should be sufficiently detailed to explain the work. It is a best management practice for the project team to hold a weekly schedule meeting to discuss upcoming work, traffic patterns and lane closures, and to document the discussions.

6. Reviewing the Revised Schedule

The Engineer should require a Revised Schedule from the Contractor when there is a major contract or schedule change. A request for the Revised Schedule is required in writing and the Contractor shall respond within 10 days of the request. The Revised Schedule must include a description and analysis of the changes, including any impact to the Contractor's planned completion date or the contract completion date. A Revised Schedule shall include all the requirements of (c) Schedule Submittals.

Require the Contractor to submit a Revised Schedule when the original Baseline Schedule no longer reflects how the work is being performed. This will help to determine if delays are attributable to the changes in the schedule or are due to something else.

108.3.2 Schedule Reports

The Contractor is required to provide several reports that facilitate a review. These reports are particularly helpful if the Contractor is using Primavera and the Engineer does not have access to the software. The Engineer may also request an exported copy of the schedule data in a spreadsheet (.xlsx) copy of the reports to help with review of the information. Tips for reviewing these reports are listed below:

1. The Job Progress Narrative Report should discuss progress and highlight and explain changes from the previous schedule submittal. It should also discuss issues that occurred, and issues anticipated in the future. A narrative should include the following items, as appropriate:

a. Baseline, Preliminary, and Revised Schedules:

It is important to review the production rates indicated in the Narrative, to check that they are reasonable and attainable. The production rates should also be compared to activity durations in the schedule to make sure that they agree. For example, if a Narrative shows a production rate of 1,000 LF/day for installation of curb and gutter and the plan quantity is 10,000 LF, the corresponding activity in the schedule should have a duration of at least 10 days. If the duration is only 5 days, discuss with the Contractor to determine how the contractor plans to accomplish this with the production rate. It could be that the contractor plans to use two crews to perform the work. Significant differences in time may indicate an error in the schedule and require additional discussion. A schedule may be “Approved as Noted” if the Engineer disagrees with minor items such as overly optimistic production rates or the logic between activities.

b. Project Schedule Update:

- Identification of actual schedule progress during the reporting period.
 - Actual progress compared to contractual milestones during this period.
 - A list of significant activities started or completed during the reporting period.
 - Explanation of lack of progress on critical path activities planned to be performed during the previous reporting period.
 - The status of major material and equipment procurements.
 - Identification of difficulties encountered (delays) during the reporting period.
 - Explanation of any significant schedule variances from the Baseline Schedule plan. If there are any, a Revised Schedule may be needed
2. The Predecessor Activity and Successor Activity Report should list the schedule logic including Lags and for each activity. It is usually difficult to read logic ties on a network diagram and when the schedule is developed using Primavera, this report can help with the review of workflow logic. Also, it can be used to verify the activities on the critical path, and any other path. In reviewing the report, look for activities with at least one Predecessor and at least one Successor, or activities that have a start-to-start relationship and only have start-to-start Successors, or activities that have a finish-to-finish relationship and only have finish-to-finish Predecessors. When this is the case and before approval, the Contractor is required to tie all activities into the schedule to determine a reliable critical path or paths and the project duration.
3. The Early Start Report lists all activities sorted by actual start, if started; and early start date, if planned. The early start is the earliest that an activity can start, based on the completion of predecessor activities. This report is intended to identify the work that is coming up next. The Contractor could use this report to develop the Weekly Planning Schedule. The Engineer will compare the report to the Weekly Planning Schedule and discrepancies should be discussed as the work progresses.

4. The Float Report lists all activities sorted in ascending order of Total Float. This report will help identify the Critical Path, Critical activities, and Near Critical activities. Delays to the Critical activities can delay the project completion date. Use this report in conjunction with the Job Progress Narrative Report and ensure the Contractor addresses significant changes to float that occurred from the last reporting period in the narrative.
5. The Critical Path Report lists the completion percentage for partially completed activities, sorted by float and then by early start. This report provides a good status of the project and could help you to identify issues that could impact completion of the project within contract time. Any changes to activities on this report should be discussed in the Job Progress Narrative Report.
6. The list of all non-workdays identifies the plan for anticipated days in the project and activity calendars with no work planned. Typically, this may include Holidays, no work periods identified in the contract such as free time, or anticipated weather days. When reviewing this report with the Preliminary and Baseline Schedules, the report should include the required non-workdays such as Saturday, Sunday, Holidays, and other contract restrictions. It is acceptable that the Contractor includes a reasonable number of anticipated weather days in the schedule and this list. This helps the schedule reflect a realistic planned completion date. When reviewing a schedule, update the planned non-workdays to reflect that work occurred. This should also match the Time Count. If this is not performed, the planned completion date is incorrect.

108.3.3 Comparison Tools (coming soon)

1. Using Excel
2. Using MSP
3. Using Primavera reports (and Claim Digger)
4. Creating an As-Built schedule

108.3.4 When to respond with “Approved, no exceptions taken,” “Approved-as-noted,” or “Revise and Resubmit”

The Engineer will approve the schedule as submitted if it is reasonable and complete. If the schedule is complete, follows the requirements, and is mostly reasonable, but the reviewer disagrees with some specific items, the Engineer will approve the schedule with notes. The notes need to be specific and focused on whether the schedule is reasonable. However, the response should not direct the Contractor’s means and methods. By approving the schedule submittal with notes, a record is created, and it can be helpful if problems arise later. Some examples of when notes are appropriate:

1. The reviewer questions the durations for specific activities and the Contractor is sure it can accomplish the work in that time, the Engineer can approve the schedule with a comment that production rates or durations seem overly optimistic. This comment will be helpful later if the Contractor fails to achieve planned production rates.

2. The reviewer questions logic between activities. Approval can include a note questioning whether it is necessary to finish final striping before setting guardrail. This is helpful when the Contractor uses preferential logic or when an activity A and activity B can be scheduled in any order.

If the Contractor submits a Baseline Schedule with a planned early completion, respond “Approved-as-noted” and include this statement:

The planned completion date reflected on (insert Contractor’s name) Baseline schedule is expected [pick one: 1) on mm/dd/yyyy; 2) after ### Working Days; or 3) after ### Calendar Days]. The Contractor’s bid includes all compensation for the work and administration of the project through the Contract completion date. When the work extends past the Baseline Schedule planned completion date up to and including the Contract Completion date of [pick one: 1) mm/dd/yyyy; 2) ### Working Days; or 3) ### Calendar Days], the Contractor is not entitled to additional time or compensation.

Finally, if there are significant reasons the Engineer cannot approve the schedule, the written response to the Contractor will include specific comments describing the reasons for revision and resubmittal. Be sure to document the dates the schedule is returned and the resubmitted schedule is received.

To assist the Engineer with enforcement, subsection 108.03(d) of the Standard Special Provision, Revision of Section 108 - Project Schedule states that no work will begin until the Preliminary Schedule or Baseline Schedules is approved. In addition, if the Contractor has submitted a Preliminary Schedule, the Baseline Schedule must be approved in accordance with subsection 108.03(e) of the Standard Special Provision, Revision of Section 108 - Project Schedule, otherwise further partial payments should not be made. If it becomes necessary to withhold payment, notify the Resident Engineer and Program Engineer to obtain their concurrence. Consistent enforcement of these subsections will help ensure that the Contractor provides reasonable and timely schedule submittals. Checklist 4 - Revise and Resubmit Schedule (Appendix B) lists issues that require revision of the Schedule. When these items are answered “yes,” consider requiring corrections and requiring the contractor to resubmit the submittal.

108.3.5 When Should the Engineer Withhold Progress Payment?

Keep in mind the work will not start until the complete Preliminary or Baseline Schedule is received and approved. Complete means the submittal includes the native file, the Job Progress Narrative, and all reports.

When a Preliminary Schedule is submitted, a Baseline Schedule is required by the 45th day after Award. Withhold payments if the complete Baseline Schedule is not received within 45 days after Award and continue to withhold until a complete schedule submittal is received. Within the first 60 days of work, the Engineer will not process a payment until a complete Baseline

Schedule is submitted. The Engineer will not allow work to continue past the first 60 days and will not make payments until a complete Baseline Schedule is approved.

When the first schedule submitted is only a Baseline Schedule, the Engineer will withhold payments when the Contractor does not submit a complete Project Schedule Update. When the Contractor submits a complete Project Schedule Update, the current monthly payment will be paid before the submittal is reviewed and approved. By the following month's payment, the Engineer will withhold payments when the schedule submittal is incomplete or is not approved. Before withholding a payment, the Engineer will discuss the reasoning with the Resident Engineer and Program Engineer and obtain their concurrence.

108.3.6 When is a Scheduling Consultant Needed?

The need to use a schedule consultant's expertise to assist in reviewing the Contractor's schedules should be analyzed before advertisement of the project. Once the need to use support is determined, including scheduling assistance in the Statement of Work of a construction management contract is the best way to provide this support. The Area Engineers have Non-Project Specific contracts available for disputes and claims and they include schedule review. Contact the Area Engineer for more information on using these contracts.

The schedule consultant selected should be skilled in schedule analysis, understand heavy highway transportation construction, and have access to the same scheduling software that the Contractor uses. Ability to review the jobsite and attend project meetings is also helpful but not required.

Consider using a schedule consultant to assist with the review of all schedules when a project is large, complex, essential to complete on time for other projects or stakeholders, or the type of work has a high potential for a delay. If a project is of medium to low complexity and includes a potential for delay, the Engineer may choose to have the schedule consultant only review the Baseline Schedule, and the Project Engineer may review the Project Schedule Updates. The Engineer may also choose the assistance of a schedule consultant to assist with the analysis of added or changed work or requests for extension of contract time.

When a consultant is supporting the Engineer, the Engineer will not hand over the schedule consultant's reports or deliverables directly to the Contractor. The Engineer is responsible for reviewing the schedule consultant's reports or deliverables and developing a response.

Checklist 5 - Schedule Risk Analysis (Appendix B) provides points to consider when analyzing schedule risk to decide if a schedule consultant is necessary. When responses are more often High or High and Medium, it is an indication that using a schedule consultant could help manage the schedule.

108.4 PAYMENT SCHEDULE

In accordance with the February 1, 2010, Memorandum issued by Executive Director, Russell George, all projects require a drawdown schedule, and the data shall be entered in the SAP system. (See Standard Special Provision Revision of Section 108 Payment Schedule (Single Construction Year). The purposes for maintaining a drawdown schedule are:

1. To aid CDOT in becoming a “cash management” organization.
2. To providing more accurate time and cost estimates - before and after budgeting projects.
3. To enhance internal communication links at key times.
4. To provide a standardized tool and approach to project management.

108.4.1 Payment Schedule

A Payment Schedule is also known as a drawdown schedule from a contractor and is required for all CDOT construction projects. The larger the project budget the more important it becomes that the drawdown schedule be managed. The contractor shall provide a Payment Schedule for the contract amount, planned force account work, and expected incentive payments. The Project Engineer is responsible for estimating and maintaining the drawdown schedule for the project’s encumbered funds not in the contractor’s control. The Project Engineer will need to account for the additional force account funds and other costs that may be expended during the construction phase.

CDOT personnel and consultant construction engineering charges paid from the CE Pool do not need to be included in the drawdown because they are captured through other processes. Bridge Enterprise and CE exempt projects where the charges are applied directly to the project are exceptions meaning the Project Engineer should include them in the drawdown schedule. If Right-of-Way, Utility, or Railroad or other funds will be paid during the construction phase, they should also be included in the drawdown schedule in the Construction WBS. Since they are generally a one-time payment, enter the estimated amount in the future month when the expected payment will be made.

The contractor is required to submit an Initial Payment Schedule at the Preconstruction Conference that includes planned force account work and expected incentive payments.

The Project Engineer shall review the submittal for completeness.

Once work begins, a Payment Schedule update is required each month by the first of each month. The best practice is to receive the update after the last progress payment is made. The Project Engineer shall review the update completeness. Drawdown schedules shall reflect the current remaining encumbered balance for the duration of construction. The drawdown data does not need to be corrected for discrepancies between actual cash flow (past) versus the drawdown schedules for previous months.

Many project drawdowns and the encumbered balance will not match, and this is expected in order to be accurate. Examples when this may happen are:

1. A construction project where the full encumbered amount will not be spent. The contract may be under budget so the encumbered funds will be more than the drawdown schedule.
2. A construction project that has been completed and there are still funds encumbered but the project has not had final payment yet. The encumbered amount will be more than the drawdown schedule.
3. A project that is running behind schedule.

108.5 LIMITATION OF OPERATIONS

Subsection 108.05 of the Standard Specifications gives the Project Engineer authority to alter the sequence of work. Such authority should be exercised with discretion, because altering the sequence of work could increase Contractor costs and result in a claim. The alteration of the planned sequence of work should only be considered if it minimizes traffic interference and is essential to public convenience.

108.6 CHARACTER OF WORKERS; METHODS AND EQUIPMENT

108.6.1 Personnel and Equipment Considerations

Poor supervision, inadequate number of workers and insufficiently maintained equipment contribute to poor progress and, in some instances, unsatisfactory work. Unsatisfactory work and poor progress frequently result in requests for time extensions, disputes, and claims. The Project Engineer and project staff must document observations of Contractor operations, equipment, and personnel to ensure that adequate information is available if it becomes necessary to evaluate a request for time extension and a dispute or claim.

108.6.2 Removal of Project Personnel

Subsection 108.06 of the Standard Specifications gives the Project Engineer authority to remove any Contractor or subcontractor personnel, including Superintendents and owners, if their work is not being performed in a proper and skillful manner. In such situations, discuss the matter with the Resident Engineer and the Region Program Engineer. If removal is necessary, request in writing, listing specific information, that the Contractor remove the personnel from the project. If the Contractor fails to comply with the request, the Project Engineer may suspend work with a written stop work order until the Contractor complies. The details of the circumstances leading to the decision will be documented in writing. The notes must be factual without personal comment or opinion.

108.7 WORKPLACE VIOLENCE

Subsection 108.07 of the Standard Specifications outlines that any representative or employee of the Contractor, or any subcontractor, who commits an act of workplace violence on the

project shall be sanctioned as provided by the Contractor's employment policies and, where appropriate, shall be reported to law enforcement authorities. At the request of either the Contractor or the Project Engineer, the Project Engineer and the Contractor shall meet to discuss appropriate actions to be taken against the representative or employee. Appropriate action may include removing the representative or employee from the project. If removal is warranted and the Contractor fails to remove the representative or employee, the Project Engineer may suspend the work by written notice until compliance is achieved.

Subsection 101.95 defines workplace violence.

108.8 DETERMINATION AND EXTENSION OF CONTRACT TIME

108.8.1 General

After the Final Office Review and the resolution of all design issues affecting the scope of work, the Project Engineer will use CPM scheduling, experience, and good engineering judgment to determine the contract time the Department will allow for completing the project. The results of this analysis will be reported on Form 859 - Project Control Data (see Appendix B).

As needed, refer to the FHWA Technical Advisory No. T 5080.15, 10/15/02 - FHWA Guide for Construction Contract Time Determination Procedures and consider the guidelines presented in the Sections that follow.

The link for this advisory is: <http://www.fhwa.dot.gov/construction/contracts/t508015.cfm>

The Project Engineer will use Microsoft Project software to facilitate and document the determination of contract time.

108.8.2 Factors Influencing Contract Time

Contract time is typically specified in working days; however, calendar days or a fixed completion date may be used if warranted by unique features of the project. Contract time will vary from project to project. Consider the following factors when determining contract time:

1. urgency of the proposed improvement;
2. impact on local businesses and property access;
3. need for coordination with other projects;
4. requirements for irrigation;
5. impacts of scheduled special events and holidays;
6. time needed for construction surveying;
7. type of traffic management required;

8. interruptions to traffic flow and required construction phasing;
9. inconvenience to the traveling public, including the traffic volume affected;
10. safety of both the public and the project workforce;
11. seasonal impacts on construction activities;
12. time required to obtain permits and mix designs;
13. time required for material fabrication and delivery;
14. concrete curing time, including placement sequence and phasing;
15. special sections and features requiring staged or phased construction; and
16. impact of local noise ordinances on construction activity.

When determining contract time, it will be necessary to establish production rates for items of work on the project. The production rates used in developing the CPM schedule should be included in the “notes” section of the software for each task. Note that accelerated production rates (i.e., those faster than the average Contractor can perform) generally decrease contract time and may increase cost and limit competition.

Production rates for items of work that are used to determine contract time should:

1. be project specific, incorporating the special features and construction sequences of the project;
2. represent the production achievable by an average Contractor, unless the work item is of a specialized or critical nature; and
3. be based on a typical eight-hour workday unless project priority or special requirements warrant the use of multiple shifts or night work.

Resurfacing projects can be an exception. The Project Engineer should establish a schedule that allows the Contractor flexibility. A flexible schedule will result in the lowest price by allowing Contractors to make efficient use of their resources.

108.8.3 Guidelines for Preparing Form 859

Appendix B presents examples and guidance for completing Form 859 - Project Control Data. Use the following procedures when preparing the CPM Schedule:

1. **List Items of Work.** List the items of work, required submittals (MHTs, Shop Drawings, Form 43, etc.) and fabrication times in the chronological order that they will be performed on the project.
2. **Determine Controlling Items of Work.** The controlling items of work on the project or is also considered an activity on the critical path. The critical path is determined by the

scheduling software based upon the logic and durations input into the program. A controlling item is not synonymous with a salient feature. A controlling item will increase the project's time to completion if its duration increases. A salient feature is an item that may be of special or political interest to scheduling but will not affect the project's overall completion schedule.

3. **Project Phasing.** Project phasing is generally established by hypothetically constructing the project. Each project phase will consist of one or more items of work, some of which may be controlling. A project phase becomes critical if by increasing its duration the project's overall completion schedule is extended.

Consider the following when determining project phasing:

- a. scheduling of material fabrication and delivery,
- b. scheduling of sequential and concurrent construction activities,
- c. completing special project features, and
- d. impacts of maintaining traffic on the facility.

It is likely that traffic management will affect construction phasing. Many projects require traffic to be maintained on one lane of existing pavement while an adjacent lane is being resurfaced. Once completed, the newly paved lane is opened to traffic while the remainder of the facility is being resurfaced.

4. **Determine Production Rates.** Determine an estimated daily production rate for each item of work included in the CPM Schedule. Production rates should be included in the "notes" section of the software for each item. Consider the following when determining production rates:

- a. **Information Sources.** As needed, use the following sources of information when determining specific production rates for the project:
 - i. CDOT Engineering Estimates and Market Analysis Unit,
 - ii. project diaries of similar projects in the same location,
 - iii. experienced Region construction personnel,
 - iv. experienced Region materials personnel,
 - v. method statements from similar projects, and
 - vi. local contractors and contractor associations.
- b. **Geographic Area.** Consider the impacts that geographic location will have on production rates. For example, the daily production rate for unclassified excavation for a project located on the plains may be different from that for a project located in the mountains. The production rate for a project in Denver may be different from a project in a more rural location.

- c. Quantities of Work. Consider the impact the project's magnitude will have in terms of the relative quantities of work required for the critical path.
 - d. Material Availability. Consider how the availability of materials will affect production rates for controlling items of work. Also, consider factors such as material sources, crushing rates, and haul distance.
 - e. Traffic Delays. Consider the impact that traffic congestion through the work zone will have on production rates.
 - f. Weather. Consider the time of year the work will be performed and the potential for weather impacts to production.
5. Determine Contract time. To determine the Contract time required to complete the work, calculate the longest logical path through the CPM schedule driven by calendars, constraints, and logic.

108.8.4 Alternative Delivery Time Methods

The following methods are innovative contract time methods and explanations of each can be found in the Innovative Contract Guide Manual

[https://www.codot.gov/business/designsupport/adp-db-cmgc:](https://www.codot.gov/business/designsupport/adp-db-cmgc)

1. A + B Method. The A + B method considers the daily road user costs in determining the low bid. If this method is used, the Department will establish the unit price for each calendar day based on the daily road user costs and include this information in the bid documents. The Contractor bids the number of days it will use to complete the project. The low bid is determined by combining the total bid price of all Contract items and the total bid price for the number of calendar days the Contractor determines will be necessary to complete the project.
2. Incentive/Disincentive Clauses. Incentive clauses motivate the Contractor for early completion of the project. Disincentive clauses are intended to recover damages to the traveling public for late completion. The use of incentive and disincentive clauses will be determined on a project-by-project basis.
3. Delayed Start Date. Where a delayed start date is used, the contract time will be controlled by the long lead-time that is required to obtain project materials (e.g., lighting and signal equipment, fabricated steel members). If this method is used, the Contract will specify a period for fabrication and delivery as well as one for the number of working days allowed for construction. Time charges will begin at the end of the fabrication and delivery period.
4. Floating Start Date. Where a floating start date is used, the earliest and latest permissible start dates will be specified with the number of working days required for the project. The use of a floating start date will be determined on a project-by project basis.

108.8.5 Guidelines for Charging and Reporting Project Time

108.8.5.1 Form 262 and Form 263

Project time charges will be determined and documented by the Project Engineer in SiteManager on either Form 262 - Weekly Time Count Report - Work Days or Form 263 - Weekly Time Count Report - Calendar Days, depending on the method used for the project. See Section 120.6.1 for additional information on documentation requirements.

108.8.5.2 Progress Schedule Considerations

Sound engineering judgment, experience, and careful examination of the Contractor's operations and progress schedule are required to properly determine project time charges. Consider the progress schedule presented in Figure 100 - 10:

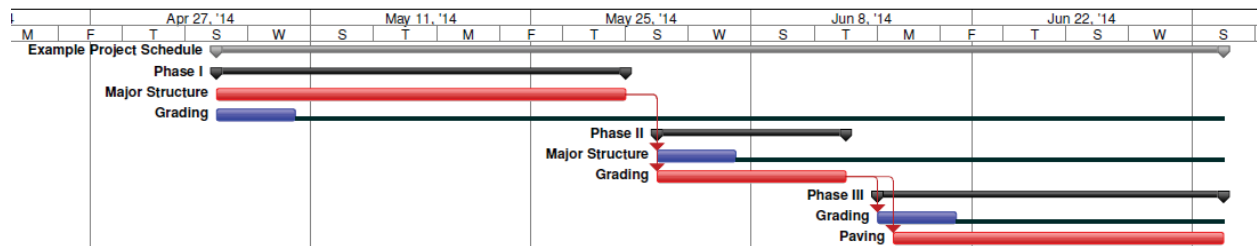

EXAMPLE PROJECT SCHEDULE

Figure 100 - 6

In Figure 100 - 7, the critical path of the project is identified by the bars in red (i.e., Phase I - Major Structures, Phase II - Grading, Phase III - Paving). The controlling item of work in Phase I is the major structure, and any delay to this work will delay completion of the project. Because grading in Phase I is not a controlling item, any delay to this item will not affect project completion. The following observations should be made regarding project time charges:

1. In Phase I, the determination of project time charges should be based on the Contractor's ability to effectively prosecute the work on the major structure.
2. In Phase 1, full days should be charged when work on the major structure can be effectively prosecuted, whether or not the Contractor works on the structure and even if the grading operation is completely shut down.
3. In Phase 1, no time should be charged if work on the major structure cannot be effectively prosecuted, even though the Contractor is able to effectively work on grading. It is possible for a project to appear active without warranting project time charges.
4. Time should be charged if the reason that the Contractor does not effectively prosecute the work was within the Contractor's control.

108.8.5.3 Charges for Full Working Days

Use the following guidelines to determine when a full working day should be charged to the project:

1. **Minimum Hours of Daily Progress.** A full working day should be charged when the Contractor effectively prosecuted the controlling item of work or was able to prosecute the controlling item of work and elected not to for at least six hours.
2. **Contractor Elected Not to Work.** Charge a full working day if the Contractor could have effectively prosecuted the controlling item of work for at least six hours but elected not to. This criterion applies as long as the reason for not prosecuting the work was under the Contractor's control.
3. **Contractor Elected to Delay Progress.** Charge a full working day if the Contractor worked on the controlling item, but the actual rate of production was slower than normally achievable. This criterion applies as long as the reason for the delay was under the Contractor's control and typically occurs when the Contractor appears to be working but is actually performing an operation that is not progressing the controlling item, such as during clean-up operations.
4. **Plant and Equipment Breakdowns.** Charge a full working day if progress on the controlling item of work was delayed by plant or equipment breakdowns. Breakdowns are under the Contractor's control.
5. **Material Delivery.** Where material delivery delays the progress of the controlling item of work, charge a full working day if the delay was caused by:
 - a. Contractor not ordering materials in a timely manner;
 - b. suppliers reprioritizing their customer deliveries;
 - c. Contractor reordering and replacing materials rejected by CDOT;
 - d. financial problems of the Contractor, manufacturer, or supplier; or
 - e. causes foreseeable by the Contractor, manufacturer, or supplier.
6. **Disputes and Claims.** If the Contractor notifies the Project Engineer of an intent to file a dispute or claim, continue to charge full working days, as appropriate.

108.8.5.4 Charges for Less Than Full Working Days

Use the following guidelines to determine when less than a full working day should be charged to the project, and provide an explanation for the decision on Form 262 or Form 263, whichever is appropriate for the method of contract time:

1. **Delays Beyond Contractor Control.** Charge less than a full working day if the prosecution of work on the controlling item was not active or active at less than full efficiency due

to a delay caused by interference beyond the control and fault of the Contractor. In such situations, charge project time as follows:

- a. Two to Six Hours of Effective Work. Charge a half day of project time if the Contractor was able to effectively prosecute the controlling item of work for two to six hours.
 - b. Less Than Two Hours of Effective Work. No time should be charged if the Contractor was only able to effectively prosecute the controlling item of work for less than two hours.
2. Adverse Weather Delays. When the Time Count basis is a Working Day Contract or Calendar Day Contract, adverse weather delays only apply to days the Contractor is allowed to prosecute the work. Use the guidelines presented in item 1 Delays Beyond Contractor Control to charge less than a full working day if the prosecution of work on the controlling item was delayed by adverse weather.

The recovery time required to attain the approximate condition of the work prior to the event should be recorded as unworkable weather. For example, after a heavy snowstorm, the Contractor is unable to work for four days. The storm started at 11 am on the first day, the Contractor could not clear the work area for the next two days, and the fourth day the subgrade was too saturated to safely allow equipment on the subgrade. If the storm occurred on a Monday, that day would be a half daytime charge and no time would be charged on Tuesday through Thursday. If the storm occurred on a Saturday for a Working Day Contract, no time would be charged on Saturday through Tuesday. If that scenario occurred on a Calendar Day Contract, no time would be charged on Monday and Tuesday. Time would be charged on Saturday and Sunday because the Contractor could not have worked, regardless of the storm.

3. Right-of-Way, Utilities, and Railroads. As a condition for advertisement and award, CDOT must certify that right-of-way, utility, and railroad work has been completed or properly coordinated with construction to avoid unnecessary delays. Coordination, if required, will be included in the contract time and Project Special Provisions. Charges for less than full working days generally will not be considered for such delays, because the Contractor should have accounted for these situations in its proposal. However, charges for less than full working days, as presented in Item #1, should be considered under the following conditions:
- a. the construction work was delayed by right-of-way, utility, or railroad interference beyond the time frame established in the Contract;
 - b. the Contractor did everything required by the Contract to minimize the delay; and
 - c. CDOT was unable to exercise effective control of the situation, despite its best efforts.

108.8.5.5 Charges for Free Time

Time count stops during “Free Time” when defined in the Project Special Provisions.

108.8.5.6 Challenges by the Contractor

If project time charges are challenged, the Contractor shall provide written notification to the Project Engineer within 30 working days of receipt of time count for the period in contention.

108.8.6 Extension of Contract Time

If an event, action, or factor beyond the control and fault of the Contractor causes an extension to the project completion date, an extension of contract time may be warranted. Contract time should be extended if the Project Engineer determines that the delays have resulted from conditions beyond the control and fault of the Contractor. In evaluating the delays, the Project Engineer should compare actual production and the Contractor's Project Schedule Update in effect at the time of delay occurrence and whether the difference is a result of circumstances beyond the Contractor's control.

Consider the following guidelines when evaluating contract time extensions:

1. Excusable Delays. Any delay to a critical activity or activities or caused the critical path to change to include the activity or activities and was not caused by the Contractor or which the risk was assigned solely to CDOT. Excusable delays are further defined as compensable (i.e., money) and non-compensable (i.e., time, but no money) as follows:
 - a. Compensable Delays. A compensable delay is an excusable delay for which the Contractor may be entitled to additional monetary compensation. For example, a design plan error caused a delay to the critical path, which resulted in a delay to project completion. The Contractor is entitled to additional compensation in accordance with 109.10.

When CDOT elects to add or changed scope, to consider additional time, the critical path must be affected. If new items are needed or existing items are modified, the compensation for additional time is typically included in the added or modified items.
 - b. Non-compensable Delays. A non-compensable delay is an excusable delay for which the Contractor may be entitled to a contract time extension with no additional monetary compensation. Examples of non-compensable delays include acts of God, acts of the public enemy, fires, floods, area wide strikes, freight embargoes, and unusually severe weather conditions. These are typically considered Force Majeure delays. Non-compensable delays also include delays caused by fuel shortage and material delivery, if the delay is due to unusual market conditions such as industry-wide strikes, national disasters, and area-wide shortages. For this type of delay, consideration of compensation will be for time only, not money.
2. Non-excusable Delays. Any delay that was reasonably foreseeable or within the Contractor's control is a non-excusable delay, and no additional time or monetary compensation will be considered. For example, a delay caused by the Contractor not placing a material order in a timely manner would be non-excusable.

3. Concurrent Delays. Occur when two or more independent delays occur at the same time or overlap for a period of time. In concept, excusable concurrent delays offset compensation to either party.

Delay Event	Concurrent with	Net Effect
Contractor Delay	Another Contractor Delay or Nothing	Non-excusable to Contractor and Compensable to Owner (LDs)
Owner Delay	Another Owner Delay or Nothing	Compensable to Contractor and Non-excusable to Owner (no LDs)
Owner Delay	Contractor Delay	Excusable to Contractor and Non-compensable to both parties
Force Majeure	with anything	Excusable but Non-compensable to Contractor

Figure 100 - 7

If it is determined that an excusable delay occurred, the Project Engineer shall extend the Contract time as soon as possible after the delay occurs and the amount of time is known. If the Contractor delays providing information to determine the amount of time owed, it is acceptable to issue a change order with the time the Engineer can substantiate. If the delay is compensable, refer to subsection 109.10. Waiting until the end of the project because the Contractor may make up the time, is not valid. The reason for issuing time as soon as possible is to avoid a claim for constructive acceleration. The Contractor may argue that the time is excusable and because time was not granted, it accelerated efforts to avoid being charged Liquidated Damages.

An extension of contract time, if warranted, requires the execution of a change order, as discussed in Section 120.7.7. The Engineer will apply the timeframes for requesting time. The Contractor is required to notify CDOT in writing within seven days and provide the full details within 30 days of the written notice. If the Contractor does not do this, they have given up entitlement to time and money. A few of other points to consider in determining an extension of time, the delay has to affect the critical path, the Contractor is required to reasonably attempt to mitigate the delay, and an approved schedule with a data date within 30 days of the delay is required. To determine the amount of time allowed, the Engineer will use either a Time-Impact Analysis, a reasonable analysis method from the AACE® International Recommended Practice 29R-03 Forensic Schedule Analysis, or another acceptable analysis method.

108.8.7 Holiday and Special Event Construction Operation Restrictions

In addition to the construction operation restrictions on Saturdays and Sundays, operations are restricted on and around New Year’s Day, Memorial Day, Independence Day, Labor Day, Thanksgiving Day, and Christmas Day. The holiday construction operation restrictions are illustrated in following two tables:

Holiday Construction Operation Restrictions								
Holiday on:	Sun	Mon	Tue	Wed	Thu	Fri	Sat	
Week 1 Week 2	Sun or Mon # @		H *			12pm		3-day hol wknd
	Tue #	12pm	H *					
	Wed #		12pm	H *				
Week 1 Week 2	Thur ^			12pm	H			4-day hol wknd
	Thur #			12pm	H *			
Week 1 Week 2	Fri or Sat #				12pm	H		3-day hol wknd
		*						

New Years, Independence, Christmas
 @ Memorial and Labor
 ^ Thanksgiving

Legend:

H	No Work - Holiday
	No Work - by contract
12pm	No work after Noon
*	Work restart

Nightwork Holiday Construction Operation Restrictions								
	Sun Night	Mon Night	Tue Night	Wed Night	Thu Night	Fri Night	Sat Night	
	Typ Schedule							
Week 1 Week 2	Sun or Mon # @		H *					3-day hol wknd
	Tue #		H *					
	Wed #			H *				
Week 1 Week 2	Thur ^				H			4-day hol wknd
	Thur #				H			
Week 1 Week 2	Fri or Sat #					H		3-day hol wknd
		*						

New Years, Independence, Christmas
 @ Memorial and Labor
 ^ Thanksgiving

Legend:

H	No Work - Holiday
	No Work - by contract
*	Work restart

Figure 100 - 8

During the preconstruction phase, considerations for additional construction operation restrictions should be considered based on the traffic volumes, special events or other factors

related to the holiday or event where operations may severely impact traffic. The Project Engineer should consult with the Resident Engineer, Region Traffic Engineer, and the region Lane Closure Strategy to help determine when additional restrictions are appropriate. If an unforeseen event not included in the contract is anticipated, subsection 105.01 of the Standard Specifications outlines that the Engineer may limit or stop work when it is determined by the Engineer to be in the public interest. The Engineer should do so with as much notice to the contractor as possible.

108.9 FAILURE TO COMPLETE WORK ON TIME

If the Project Engineer determines the Contractor may not complete the work within contract time, he will write a Form 105 to the Contractor advising him that liquidated damages will be assessed. The Form 105 will include the amount charged per day and the anticipated date contract time will end. The Project Engineer will continue to track time in SiteManager® time count forms. If the contract time is a fixed completion date and was not tracked in SiteManager®, the Project Engineer shall start tracking time.

108.10 DEFAULT OF CONTRACT

Default of contract and termination may adversely affect a Contractor's ability to work on future projects. It is important that CDOT uniformly and fairly evaluate the circumstances leading to these actions. Default of contract or termination is a contract administration issue that rests with the Chief Engineer.

If situations arise that may lead to the default or termination of any construction contract or default of any contractor or consultant, the Resident Engineer and the Project Engineer will immediately notify the Construction Services Area Engineer, the Program Engineer, and the Region Transportation Director. The Resident Engineer will obtain preapproval from the Program Engineer and the Region Transportation Director. The Resident Engineer will be prepared to discuss the circumstances leading to the default or termination with those individuals.

The Area Engineer will notify the Project Development Services Branch Manager, Construction Engineering Services Branch Manager, and Attorney General's CDOT Representative.

The Area Engineer will coordinate the collection and review of documentation that will be used to make a decision. Based on information and input collected, the Construction Engineering Services Branch Manager will make a recommendation for appropriate action to the Chief Engineer. Only the Chief Engineer can issue a Notice of Intent to Default or terminate a contract.

108.11 TERMINATION OF CONTRACT

See Section 108.10 Default of Contract.

SECTION 109 MEASUREMENT AND PAYMENT

Section 109 of the Standard Specifications defines the methods used to compensate the Contractor for the work performed. Documentation required under Section 109 is extensive and is fully discussed in Section 120 of this Manual.

109.1 MEASUREMENT OF QUANTITIES

It is imperative that Project Engineers and Resident Engineers verify the accuracy of interim payments to Contractors. Justifying interim payments based solely on information submitted by the Contractor, (i.e., load counts), is unacceptable. The Project Engineer must independently verify that work has been completed pursuant to the specifications and the Resident Engineer is responsible to ensure that quantities are reasonable before authorizing the pay estimate.

The term, “estimated quantity”, means a quantity that is calculated approximately. It is the Project Engineer’s responsibility to calculate estimated quantities as accurately as possible so as not to overpay the Contractor.

109.1.1 Scale Certification

The Measurement Standards Section of the Colorado Department of Agriculture must license scales used by the Contractor. Each time a scale is installed at a new location, an approved company must check the scales and provide an in-service report before the scale can be operated. The governing criteria related to scale certification, based on State Statute and the Colorado Department of Agriculture, include:

1. a basic tolerance of two pounds in 1,000 pounds;
2. checking of scales once each year by the Colorado Department of Agriculture.
3. renewal of scale license each year before June 30th; and
4. prohibition of split weighing under Colorado Revised Statute 24-91-103(2).

109.1.2 Requirements for Federal-Aid Projects

109.1.2.1 Verification of Manual Weighing Operations

On projects where loaded truck weights are entered manually on scale tickets, the certified weigher must be checked at least once, and more often as deemed necessary by the Project Engineer. These checks will be performed as follows:

1. Randomly Select One Truck. The Project Engineer will randomly select one loaded truck after it has been issued a scale ticket from the certified weigher.

2. **Reweigh Loaded Truck.** The loaded truck will be reweighed in the presence of the Project Engineer.
3. **Check Tolerance.** The scale reading of the reweighing will be compared to the weight reported on the certified weigher's original scale ticket. To be acceptable, the scale reading must be within plus or minus 200 pounds of the weight reported on the original scale ticket.
4. **Determine Cause of Problem.** If the comparison of the two weights is found to be out of tolerance, factors other than human error should be ruled out before consideration is given to replacing the certified weigher. The Project Engineer must assess this situation carefully on a case-by-case basis. It is recommended that both the Project Engineer and the Contractor Superintendent, or authorized designee, be present at the site during the scale inspection. Consider the following recommended procedures:
 - a. **Check for Malfunctions.** Inspect the operation of the scale for malfunctions (e.g., lodged or jammed foreign objects, worn or broken parts). Repairs may be needed.
 - b. **Check Calibration.** Check the calibration of the scale for accuracy. Certified test weights, if available, may be used to ensure that the scale has not lost calibration. The Measurement Standards Section of the Colorado Department of Agriculture should be contacted if it is suspected that the scale is no longer calibrated.
 - c. **Reweigh Additional Trucks.** If previously weighed loaded trucks with scale tickets are still available at the site, two to three additional comparison checks should be performed, and their tolerance verified. The suspect scale ticket may have been an isolated incident. In addition, consider having the certified weigher perform one of these checks, and observe the weigher's procedures and methods. Retraining may be necessary.
 - d. **Other Factors.** Once satisfied that the cause is not an anomaly, malfunction, or calibration issue, the Project Engineer should consider the facts and the severity of the problem before deciding to replace the certified weigher. Other factors may be at play.
5. **Replace Certified Weigher.** The Project Engineer must notify the Contractor in writing prior to replacing the certified weigher. Remember to check the certification credentials of the new weigher.
6. **Notify Measurement Standards Section.** All certified weighers that are replaced for inaccurate weighing should be reported to the Measurement Standards Section of the Colorado Department of Agriculture (303) 866-2845. The CDOT personnel assigned to report the incident should be knowledgeable of the facts and provide the following information to the Measurement Standards Section, because a regional scale inspector may need to return the call for investigation purposes:
 - a. name,
 - b. phone number,
 - c. scale location,

- d. certified weigher's name,
- e. certified weigher's license number, and
- f. a brief description of the problem encountered.

109.1.2.2 Verification of Computerized Scales

The Project Engineer will verify the accuracy of computerized scales. Verification procedures are detailed in Standard Special Provision, Revision of Section 109 - Measurement of Quantities.

109.2 SCOPE OF PAYMENT

109.2.1 General

The Project Engineer may expect situations during construction that require work beyond the scope of the Contract. Such situations are common and must be evaluated on a case-by-case basis to determine if the Contractor should be paid additional compensation.

109.2.2 Incidental Work

It is seldom possible or desirable to develop plans that completely cover all Contract work in minute detail. Costs of design would be prohibitive and improvements of questionable value.

Compensation for all work necessary to properly complete the project shall be included in the Contract unit prices. Subsection 104.02 of the Standard Specifications defines conditions that may warrant additional compensation. Contractors generally will provide for minor contingencies in their bids. Only differing site conditions and/or significant changes in the scope of the work should be considered for additional compensation.

The Summary of Approximate Quantities in the plans shows the pay items for which the work and materials are to be paid. Work or materials that are essential to the project but for which there are no pay items included in the plans will not be measured and paid for separately but should be included in the work. This work or materials are usually minor in nature and reasonable for a Contractor to anticipate in preparing his bid. An example is removal of asphalt mat. If the Summary of Approximate Quantities did not include the item and it is obvious by review of the plans or work site that this work is required, then no additional payment for this work should be made.

Only differing site conditions or significant changes in the character of the work as described in subsection 104.02 of the Standard Specifications should be considered for extra work. If, however, work is described and detailed with specifications that show a pay item as basis of payment and the designer has inadvertently omitted the pay item from the Summary of Approximate Quantities, the Project Engineer may make additional payment to the Contractor as in subsection 109.04 of the Standard Specifications. An example could be an expansion device shown in the plans with specifications that indicate the basis of payment is by the linear foot. If the designer failed to add the pay item or note that this device was included in the work, it may be unreasonable to expect the Contractor to include this device in his bid. The Project

Engineer may negotiate a change order to add a pay item for this work according to subsection 104.03 of the Standard Specifications.

109.3 RESERVED

109.4 COMPENSATION FOR CHANGES AND FORCE ACCOUNT WORK

109.4.1 Compensation for Extra Work

Compensation for extra work, as defined in subsection 104.03 of the Standard Specifications, must be authorized by a change order and paid for on a unit price, lump sum, or force account basis.

109.4.2 Force Account

Avoid the use of force account, particularly on work involving large sums of money. If a force account is warranted and the Contractor disputes (i.e., refuses to sign) a daily Form 10 - Inspector's Report for Force Account Work, the Project Engineer will require the Contractor to prepare a Form 10 that documents the items the Contractor believes to be eligible for payment. The Contractor must furnish this Form 10 prior to starting the work in question on the next working day. See Appendix B for a sample Form 10.

109.4.3 Specialty Work

109.4.3.1 Specialty Firms

A "specialty firm" is a term that is used in subsection 109.04(e) of the Standard Specifications. It is a term that is not defined elsewhere in the Contract. Billings from a specialty firm are eligible for administrative loading. All other force account rules apply to specialty firms.

109.4.3.2 Specialty Items

Subsection 108.01 of the Standard Specifications uses the term specialty item. On Federal-Aid projects, FHWA Form 1273 - Required Contract Provisions - Federal-Aid Construction Contracts defines specialty items as follows:

Specialty items shall be construed to be limited to work that requires highly specialized knowledge, abilities, or equipment not ordinarily available in the type of contracting organization qualified and expected to bid in the Contract as a whole and in general are to be limited to minor components of the overall Contract.

Subsection 108.01 of the Standard Specifications requires specialty items to be specified in the Contract.

Contract Administration Considerations

The following Contract administration procedures apply to specialty work:

1. Form 205 - Sublet Permit Application is required for all specialty work;
2. certified payrolls are required for all specialty work on Federal-Aid projects; and
3. force account work will be paid according to subsection 109.04 of the Standard Specifications.

With regard to Contract administration, administer specialty firms and specialty items in the same manner as other subcontractors are administered on the project.

109.5 ELIMINATED ITEMS

Items that are not necessary to prosecute work on the project may be eliminated from the Contract using Form 105 - Speed Memo to notify the Contractor. If the Contractor has incurred costs from prosecuting the item, a change order must be executed to compensate the Contractor. However, a change order is not needed if costs have not been incurred. Elimination of items does not qualify for a Value Engineering Change Proposal.

109.6 PARTIAL PAYMENTS

109.6.1 Preparation and Processing of Estimates

The Project Engineer will prepare monthly partial payment estimates for the work performed during each month of the Contract. Consider the following:

1. Delayed Partial Payments. The Project Engineer will notify the Contractor, in writing, of the reason for any delay to a partial payment. The notification should be given in advance of the estimate cutoff date, if possible, so the Contractor will have time to correct the deficiency before the estimate is due. All Contractor requests to delay a partial payment to permit inclusion of a specific amount of work shall be made in writing. The Contractor shall notify each subcontractor who has performed work during the payment period of the reason for the delay.
2. Copies of Partial Payment Estimates. The Project Engineer will provide the Contractor with a copy of all partial payment estimates. The Contractor should provide a copy of the estimate to each subcontractor that has performed work during the period covered by the estimate. CDOT will assist subcontractors in obtaining this information and will furnish the subcontractors with a copy of the estimate, if requested.
3. Partial Payment. The Resident Engineer will electronically transmit partial payment approval to Division of Accounting and Finance. Accounting will transfer the payment request to COFRS. The State Controller's Office then processes a payment warrant to the Contractor five to seven days after the Resident Engineer authorizes partial payment approval.
4. Electronic Funds Transfer. The Contractor can authorize CDOT to electronically transfer funds directly to its account. Electronic Funds Transfer forms are available from the Accounts Payable Office at dot_accounts_payable@state.co.us. The Contractor should be

reminded of this option at the Preconstruction Conference. Funds are normally available in four to five days after the Resident Engineer authorizes partial payment approval.

5. Prompt Payment. Subsection 109.06 Partial Payment allows the Contractor to withhold retainage from subcontractors or suppliers. Once all of the subcontractor's work is complete and accepted by CDOT, the subcontractor or suppliers may follow the process in 109.06 (f) to have retainage released.
6. Monthly Reporting. For CDOT projects, by the 15th of each month, the Contractor shall record all payments to subcontractors by completing an audit in the B2GNow System.
7. Fuel Cost Adjustment. Contract cost adjustments will be made to reflect increases or decreases in the monthly average prices of gasoline, diesel, and other fuels from the average price for the month preceding the month in which bids were received for the Contract, assuming the Contractor elected to accept this option on the Form 85 at the time of bidding.
8. Asphalt Cement Cost Adjustment. Contract cost adjustments will be made to reflect increases or decreases in the monthly average price of asphalt cement from the average price for the month preceding the month in which bids were received for the Contract, assuming the Contractor elected to accept this option on the Form 85 at the time of bidding.
9. Maximum Partial Payments. Partial payments will not be made in excess of the encumbrance amount except at the sole discretion of the Department. Work performed in excess of the encumbrance amount, without written approval of the Department, shall be performed at the Contractor's risk.

109.6.2 Reduction of Retainage

109.6.2.1 Retainage by the Contractor

If during the prosecution of the project, a subcontractor satisfactorily completes all work described on CDOT Form 205, or as amended by changes directed by the Project Engineer, the Contractor can request final payment for the subcontractor's work and concurrence to release the subcontractor's retainage. At that time the Project Engineer will inspect, measure, and furnish final quantities for all work listed on that subcontractor's Form 205. All paperwork (payrolls, materials certifications, FHWA Form PR-47, etc.) will need to be submitted and correct before the Project Engineer will authorize final quantities for a subcontractor's work. These quantities will NOT be adjusted at the end of the project, so it is imperative that these quantities are accurately measured and paid for in accordance with the contract requirements.

If the total dollar amount of the subcontracted work, as described on the CDOT Form 205, exceeds \$100,000, the Project Engineer is strongly advised to submit the final quantity calculations to the Region Finals Administrator for review, prior to agreeing on the quantity with the Contractor.

Upon CDOT's release of subcontractor's final payment, the Contractor shall release the subcontractor's retainage. Final measurement of the subcontracted item shall not constitute acceptance of the work.

109.6.2.2 Prime Retainage

When the Contract has been completed, the Contractor may request the Department to reduce the amount of retainage or securities withheld. Such requests must be made in writing to the Project Engineer. The amount of withholdings may be reduced to a value of \$1,000 or one-tenth of one percent of the Project Commitment Amount, whichever is greater. The Project Engineer may withhold a greater amount if a valid reason for doing so can be substantiated. CDOT will consider a reduction request only if all the following conditions have been met:

1. the Contractor has completed the project,
2. the Department has accepted the project.
3. the Contractor has submitted all required forms and paperwork,
4. the Project Engineer has approved the final pay quantities, and
5. a written consent has been received from the surety company.
6. the Contractor has complied with all DBE and OJT requirements and is not subject to a payment reduction.

If the Contractor meets the above requirements, the reduction should be made before submission of the final to the Region Finals Administrator. If the Contractor meets the requirements after submission of the final, the Region Finals Administrator may make this reduction as soon as all the documentation is received.

The Project Engineer should have sufficient justification for withholding retainage. Contact the Construction Services Area Engineer for guidance.

109.6.3 Subcontractor/Supplier Liens

If payment is not made in accordance with the Prompt Payment Act, Colorado Revised Statute 24-91-103(2) and Colorado Revised Statute 38-26-107, permits subcontractors and suppliers to file liens against the Contractor. Such liens are different from claims for Contract adjustments, which are processed in accordance with subsection 105.22 of the Standard Specifications. Liens that are filed under the Prompt Payment Act will be processed in accordance with the following procedures:

1. When the Center for Accounting receives a properly completed lien (claim), the Center for Accounting will immediately forward a copy of the lien (claim) to the Resident Engineer in charge of the project and the Region Program Engineer. Prior to making further payments to the Contractor, the Resident Engineer will enter a separate line item for each lien on the estimate and withhold the amount of the lien (claim) from payments due the Contractor. The amount withheld shall be in addition to retainage and/or

securities. The Region shall not submit the final estimate to the Center for Accounting until all liens (claims) has been resolved.

2. If the lien (claim) is released and the Contractor furnishes the Center for Accounting with the properly completed lien (claim) release, the Center for Accounting will immediately forward a copy of the lien (claim) release to the Resident Engineer and the Region Program Engineer. The Region will pay the amount withheld and zero out the lien (claim) line item
3. If a lawsuit has not been filed and the Center for Accounting has not received a notice of lis pendens within ninety days after the final settlement date, the Center for Accounting will forward a lien (claim) release notice to the Resident Engineer and the Region Program Engineer. The Region will pay the amount withheld and zero out the lien (claim) line item.
4. If a lawsuit is filed and the Center for Accounting receives a notice of lis pendens within ninety days after the final settlement date, the Center for Accounting will immediately forward a copy of the lis pendens to the Resident Engineer and the Region Program Engineer. The Region will continue to withhold the lien (claim) amount.
5. If the lawsuit is settled out of court, the Center for Accounting will immediately forward a copy of the lien (claim) release to the Resident Engineer and the Region Program Engineer. If a court judgement is reached, the Center for Accounting shall consult with the Attorney General before forwarding instructions to the Resident Engineer and Region Program Engineer, which must detail how and to whom payment shall be made. The Region will make payment in accordance with the instructions from the Center for Accounting.

Lien forms can be obtained from the Center for Accounting.

The Resident Engineer should ensure that all liens and any questions related to subcontractor and supplier liens be directed to the Center for Accounting at cdot_lien_related@state.co.us.

109.6.4 Fuel Cost Adjustment

Contractors are allowed to “opt-in” (accept) or “opt-out” (not accept) Fuel Cost Adjustments by checking the appropriate line on the Form 85, “Contractor’s Proposal”. They are required to turn in Form 85 at the time they submit their bids. Contractors are not allowed to change their minds regarding Fuel Cost Adjustments after bids are opened.

After receiving a copy of the executed Contract from Construction Services, the Resident Engineer will notify the Project Engineer whether or not to make Fuel Cost Adjustments.

The Project Engineer will pay for the Fuel Cost Adjustment under F/A Fuel Cost Adjustment, Pay Item 700-70016. If the amount of actual Fuel Cost Adjustments exceeds the funding allotted in the Planned Force Account, the remainder of the adjustments should be made using funding from Minor Contract Revisions (MCRs), or by adding funding to the project.

Fuel Cost Adjustments will be made only to those items listed in the specification. The table in the standard special provision lists specific items and associated fuel factors that were

developed through cooperation between CDOT and the contracting community. The adjustable pay items are listed in the specification.

If the Contractor accepted Fuel Cost Adjustments, the Project Engineer should calculate the adjustments once per month.

https://www.codot.gov/business/designsupport/cdot-construction-specifications/2019-construction-specifications/fuel-cost-adjustments/opis_denver_ultra_low_sulfur_diesel_lub

To calculate the adjustment, use the spreadsheet found the bottom of the page at the website referenced above. The spreadsheet contains additional detailed instructions regarding Fuel Cost Adjustments.

Retroactive Fuel Cost Adjustments will not be allowed. In other words, this standard special provision should not be applied or change-ordered into any Contract that did not contain it at the time of bid opening.

109.7 PAYMENT FOR MATERIAL ON HAND (STOCKPILED MATERIAL)

Only material, which meets Contract requirements and has been fabricated or processed and is ready for installation into the project is eligible for payment, with the following exception:

This section specifies that payment for structural steel (unfabricated milled plate) may be made on projects where the plan quantity of structural steel exceeds one million pounds. The Project Engineer may pay for 60 percent of the invoice cost of the structural steel (unfabricated milled plate) delivered to the fabrication plant. The stockpile location and/or fabrication plant do not have to be in the State of Colorado.

See Section 120 of this Manual for further information and documentation requirements.

109.8 RESERVED

109.9 ACCEPTANCE AND FINAL PAYMENT

109.9.1 Processing Procedures

As the project nears completion, the Project Engineer should discuss completion and cleanup requirements with the Resident Engineer and Maintenance Superintendent, including items requiring maintenance or removal such as temporary erosion control measures and permanent drainage features. To expedite final acceptance, a punch list should be provided to the Contractor when the work is nearly complete.

Once the punch list items have been substantially completed, the Project Engineer should schedule a Final Inspection review meeting. The suggested attendance for this meeting includes the Project Engineer, Resident Engineer, Program Engineer, Contractor, Maintenance, specialty groups and local agencies/jurisdictions as necessary. On Full Oversight projects, the FHWA must be invited.

On the same day, the Contractor has satisfactorily completed all work in accordance with the Contract; the Project Engineer will prepare and forward an Acceptance Letter to the Contractor. See Section 120.3.2 for additional guidance. A copy of the Acceptance Letter must be transmitted to the Region Finals Administrator, the Program Engineer, the Resident Engineer, and the Projects & Grants Accounting.

109.9.2 Requirements for Federal-Aid Projects

Form 1212 - Final Acceptance Report is required for all Federal-Aid projects. The Resident Engineer will verify the proper completion of the following items:

1. Form 473. Letter of Materials Certification has been properly completed and submitted.
2. Right-of-Way. Has been inspected and is free of apparent unauthorized encroachments.
3. Safety Deficiencies. Project has been reviewed for obvious safety deficiencies. Comments regarding liquidated damages and dollar amounts and time extensions associated with claim resolutions may be included in the remarks section of Form 1212. However, comments regarding corrective work or deficiencies should not be included on Form 1212, because such items must be corrected prior to final acceptance.

The Project Engineer notifies the Contractor of project acceptance in writing and sends a copy to the Region Finals Administrator. Once the Finals Administrator enters the final acceptance date in SiteManager®, SAP sends an email message to the Resident Engineer stating the Form 1212 can be completed. When the Resident Engineer fills out the SAP Form 1212, the Resident Engineer will need to distribute.

Note that no changes can be made to the SAP Form 1212 after completion, only a checked box will indicate that the Form 1212 has been completed in SAP.

Any missing check marks on the Form 1212, as well as any deficiencies noted in the remarks section will need to be resolved before initiating the Form 1212 in SAP prior to final distribution to the Finals Administrator as outlined in Figure 100G of the Construction Manual [original to FHWA and copies to Construction Services and the Projects & Grants Accounting. Any exceptions need to be discussed with the Area Engineer and FHWA Operations Engineer.

The Form 1212 must be complete in order to close the project. Failure to complete the Form 1212 in a timely manner may cause the project to be labeled as inactive with FHWA and ties up funds that could be used for other projects.

109.10 COMPENSATION FOR COMPENSABLE DELAYS

Subsection 109.10 of the Standard Specifications establishes the basis for quantifying compensation for compensable delays. The Contractor must provide evidence that the delay was compensable in accordance with subsection 105.22 and subsection 108.08 of the Standard Specifications. All costs must be documented by the Contractor, reviewed, and approved by the Project Engineer.

SECTION 120 DOCUMENTATION REQUIREMENTS

This Section defines the documentation required by CDOT to ensure that adequate records are maintained during contract administration. Documentation is required by law and is an essential part of contract administration. CDOT's goal is to be as paperless as practical. The Project Engineer and project team will strive to generate and keep all documentation in an electronic format. Exceptions to not using electronic documentation will require Project Engineer to seek approval from the Resident Engineer and Program Engineer. This includes obtaining electronic documentation from other parties. Appendix B and Appendix C include examples with instructions for many of the letters, notices, and forms that are used.

120.1 PROJECT RECORD

A Project Record is a construction record as set forth in the Record File Plans relevant to construction and each specialty areas. The Record File Plans include all documents, books, papers, maps, photographs, or other documentation materials, regardless of physical form or characteristics, made or received by CDOT. A record may be inscribed on a tangible medium or that is stored in an electronic or other medium.

When this Construction Manual refers to documentation, it is a record, written or electronic, developed during the administration of a construction contract. All documentation is subject to Federal and State audits and reviews. All documents will contain the project number and project code (subaccount).

120.1.1 Signatures

Obtaining electronic signatures is an important step toward achieving CDOT's goal to be paperless. The definitions and distinctions between the terms digital signature, electronic signature, and certificate-based signature, are complicated. CDOT has simplified the decision-making surrounding what type of signature and where a particular signature type will be used. Any questions related to signatures should be directed to the Records Management Program at dot_records_mgmt@state.co.us. Additionally, CDOT employees can view the electronic signature guidance is available at:

https://drive.google.com/file/d/1lc_ZjyibTdbCX9NTgPbrbtHiy-im-59M/view

Signature Type 1

Documents requiring a Signature Type 1 are the Form 90 and any document requiring a Professional Engineer, Professional Architect, or Land Surveyor Seal. Adobe Sign will be used for signatures in this category.

Signature Type 2

A Signature Type 2 is simply every signature which is not a Type 1. Documents that may use a Type 2 are related to tasks such as initialing, tracking, approving, certifying, creating, quality control confirmation, read receipts, or acknowledgement of the handling, conformance, and management of a document. Type 2 signatures are related to documents such as a Project

Diary, pay documentation, payment voucher for estimates, change order letter of explanation, Project Termini Extension letter of explanation, Speed Memo, Certificate of Compliance, or Buy America certification. Adobe Sign will not be used for documents in this category. This decision is based on the cost for each use. Other acknowledgment methods that may be used in lieu of Adobe Sign for this category include an Adobe Acrobat Pro DC certified signature, Blue Beam, login verification, or a scanned handwritten signature.

120.1.2 Active Construction Document and Data Management

Project Records will be accurate, complete, and easily understood. Documents will be prepared in a manner that will allow individuals not familiar with the project to easily determine what was performed, even if reviewed several years later.

ProjectWise Explorer is CDOT’s active project Electronic Document Management System (EDMS) for archiving Project Records. Bentley Project Share is a companion cloud storage space and may be used for day-to-day file sharing with the contractor and other third parties and to place Project Records while the project is active.

Information input into SiteManager and SAP does not need to be placed in the ProjectWise. Information input into data collection software such as Survey123, will be placed into ProjectWise. If information does not need to be retained for 3.5 years or longer and is collected in digital datasets within programs (e.g., Survey123, SAP, SiteManager), the information does not need to be rendered in PDF documents.

All pay documentation that is not in SiteManager® will be archived in ProjectWise Explorer and referenced in SiteManager® so the documentation can be easily located.

Construction Software Nomenclature for Electronic Documentation		
Software Name	Also Known As <i><u>Construction Manual term</u></i>	Access software via...
ProjectWise Explorer	ProjectWise Design Explorer <i><u>ProjectWise</u></i>	Desktop application
ProjectWise 365 Services Bentley Cloud Services Bentley Connect	<i><u>ProjectWise Services</u></i> Includes: Project Share, ProjectWise Web Connections, Deliverables Management	Webpage
Connection Center	<i><u>Connection Center</u></i>	Desktop application
ProjectWise Share	<i><u>Project Share</u></i>	Webpage
ProjectWise Deliverables Management	<i><u>Deliverables Management</u></i>	Webpage
Adobe Sign	<i><u>Adobe Sign</u></i>	Webpage or email link or Adobe DC
Adobe Acrobat Pro DC	<i><u>Adobe DC</u></i>	Desktop application

Construction Software Nomenclature for Electronic Documentation		
SAP	SAP	Desktop application and Web portal
AASHTOWare SiteManager	SiteManager	Virtual Desktop

Figure 100 - 9

120.1.3 Original Source Document

The original source document is the document or electronic file on which the information was recorded that supports the final pay quantity, for example the DWR in SiteManager, an electronic copy of CDOT Form 266, or a spreadsheet. The information must document payment according to the procedures described in Section 120.15.2 Methods of Measurement, including supporting calculations and measurements as needed. The original source document must be attached to or referenced on the document that authorizes payment. The term “original source document” does not imply that notes on scratch paper or written documentation created in the field must be included in the documentation to support payment. The original source document may be an electronic document transcribed or created from such notes or documentation. The notes do not need to be included in the final documentation that is submitted to the Finals Administrator but will be Smart Scanned and retained in project files.

120.1.4 SiteManager® Electronic Documentation

Electronic documentation in SiteManager® will be processed as follows:

1. Access Agreement. Each user must sign a SiteManager® access agreement to create an individual account. The access agreement provides a password for the individual to utilize when accessing SiteManager®. The access agreement establishes that data entered into SiteManager® under each individual user’s password is equivalent to signing the following statement:

The item(s) and material(s) were inspected and found to conform reasonably to the Contract Plans and Specifications except as noted.

A copy of the access agreement can be obtained from the SiteManager® website at: https://www.codot.gov/business/engineering_applications/project-construction/aashtoware-project-construction-sitemanager-access.

2. Username Entries. SiteManager® automatically records the name of the person entering project data. If a different person performed the measurements or calculations, enter this person’s name in the proper record.
3. Electronic Copies. At the Project Engineer’s option, an electronic copy of the daily work report or Form 266 - Inspector’s Progress Report may be maintained in addition to the electronic version in SiteManager®. At the Project Engineer’s discretion and copies of supporting information that cannot be easily entered into the electronic version of the daily work report

(e.g., measurements, charts, and sketches) may be properly referenced in the daily work report and maintained as a separate electronic document.

120.1.5 Photographs and Video Recordings

When photographs or video recordings are taken on a project, the following information is to be included with the record:

- project number and project code.
- name of the person who took the picture or video recording.
- date and time the picture or video recording was taken; and
- location and approximate station number or mile marker.

120.1.6 Required Documentation from Contractors

Before the Project Engineer submits a monthly Contractor pay estimate to the Resident Engineer, the Project Engineer will fill out and update the Required Document checklist to verify and document that all required documents have been received from the Contractor. The Project Engineer will update and submit the checklist to the Resident Engineer upon first use and with each pay estimate.

The Resident Engineer will review and approve the checklist prior to approving each pay estimate. The Project Engineer will keep the approved checklist in the project files.

General Provisions

Required Documentation				
Submittal submitted prior to:	Construction	Use	Date Received	Date Approved
Baseline or Preliminary CPM Schedule and Reports: 108.03, Baseline or Preliminary Schedule within 14 days of Award of the Contract.	X			
Written List of All Permits: 107.02	X			
Proposed Subcontractors	X			
Sublet Permit Applications, Form 205 (approved prior to use)		X		
Form 1425: 106.01, at Preconstruction Conference or a minimum of 2 weeks prior to material delivery. Update to add new suppliers throughout the project.		X		
Form 1420:(w/ Form 1415 if new DBE commitment) As necessary to make modifications to DBE utilization plan or request DBE participation waivers.		X		
Mix Designs: HMA, concrete, etc.		X		
List of Haul Vehicles Legal Loads		X		
Project Safety Management Plan: 107.06	X			
Insurance Certificate: 107.15	X			
Transportation Management Plan (TMP) [may incl. Traffic Control Plan (TCP), Transportation Operation Plan (TO) and Public Info (PI)] 630.10	X			
Transportation Management Plan Completed exercises in the evening. (TMP) [may incl. Traffic Control Plan (TCP), Transportation Operation Plan (TO) and Public Info (PI)] 630.10		X		
Method of Handling Traffic (MHT) Initial 630.10(a)	X			
Method of Handling Traffic (MHT) Other 630.10(a)		X		
TCS Certification: at Precon, 630.11	X			
Flagger Certification: 630.14		X		

Required Documentation				
Submittal submitted prior to:	Construction	Use	Date Received	Date Approved
Contractor's Schedule for Temporary and Permanent Erosion Controls 208.03	X			
List of Potential Pollution Sources: 107.25(b)6	X			
Spill Prevention, Control, and Countermeasure Plan (SPCC): 107.25(b)6	X			
Surveying Schedule: 625.03 submitted prior to Pre-survey Conference	X			
Form 1337, Contractor Commitment to Meet OJT	X			
Requirements: no later than Precon				
Form 1378, Contractor Selection of Litigation or Arbitration	X			
Contractor's EEO Policy and Procedures	X			
Letter confirming EEO Policies and Procedures orientation meeting was presented to supervisory personnel: prior to construction and every 12 months	X			
Letter describing Contractor's EEO complaint procedures	X			
Letter describing Contractor's method and schedule for monitoring subcontractor EEO compliance schedule	X			
Letter communicating Contractor's tentative date of first project EEO meeting	X			
Project Engineer:				Date:
Resident Engineer:				Date:

Figure 100 - 10

120.1.7 Responsibilities

120.1.7.1 Resident Engineer

The Resident Engineer is responsible for ensuring that complete and accurate documentation is compiled.

120.1.7.2 Project Engineer

The Project Engineer will compile, or cause to be compiled, and verify, the required documentation. The Project Engineer is responsible for Archiving Project Records in ProjectWise on a continuing basis.

120.1.7.3 Bridge Inspector

The Project Inspector has the primary duty of ensuring that construction is performed in accordance with the Contract. The Project Inspector is the representative of the Project Engineer and will maintain complete and accurate records of the work performed, the materials used, the disposition of rejected materials, and the measurements of the items inspected.

120.2 ARCHIVING

All archived documents will be stored in ProjectWise per the Record File Plan. When project documentation is finalized or no longer needed for active construction, it will be archived. ProjectWise does not replace LIMS, SiteManager, B2G, LCP Tracker or other software systems currently being used as a repository for documents or data. Project staff will move completed documentation to ProjectWise throughout the duration of the construction project to minimize the effort needed for archiving when construction ends and to ensure an up-to-date record set during the life of the project.

Archiving for documents to be permanently retained includes Smart Scanning. Smart Scanning means rendering the PDF searchable, page aligned, and in the ISO 19005 series PDF/A-1b format. Smart Scanning is not just scanning and is the process CDOT developed that includes a range of tasks that supports archiving documents to be retained more than 3.5 years. Smart Scanning and Digital Signatures (eLearning) (COURSE 89002) training is available on the SAP Learning Management System. Archiving also includes using a standard naming convention and placing the document in the correct location in ProjectWise. The Record File Plan identifies the retention period and where to archive documents. The Record File Plan is in ProjectWise and can be found at the following link: [5 - Record File Plans](#).

Since a PDF/A-1b format document does not retain signature encryption, for documents where Adobe Sign used to sign you will archive two documents. One document will not be in the PDF/A-1b format and will retain the signature encryption and the other will be PDF/A-1b compliant and lose encryption. Refer to Appendix D for the instruction on how to create a PDF/A-1b document of an encrypted Adobe Sign document.

Contact the Region Finals Administrator or Area Engineer with questions about documents not listed in the Record File Plan.

120.3 CORRESPONDENCE

120.3.1 Letters

Letters for all correspondence outside the Department will be prepared on CDOT letterhead. Letters should not include any logos other than the current CDOT logo, as specified by the unified state brand system. CDOT branding guidance is available at:

https://www.codot.gov/assets/2019_codot_quickguide.pdf

Use Letters to document the following:

1. Partial or Final Acceptance
2. Dispute or Claim decisions
3. Written Notice of intent to default
4. Written Contract Termination Notice
5. Complex issues involved in Contract performance that require lengthy responses

120.3.2 Acceptance Letters

Acceptance Letters (see Appendix B) for final project acceptance should, at a minimum, contain the following information:

1. date and time of acceptance;
2. a detailed list of documentation and forms that the Contractor must submit before the Project Engineer is permitted to reduce retainage;
3. a detailed list of documentation and forms that are required from the Contractor before submittal of the final estimate for payment;
4. date that the final estimate quantities will be available for Contractor review;
5. name and telephone number of the CDOT contact person from whom the Contractor can obtain information regarding the final estimate; and
6. recognition of any portion of work that exhibits an exceptional product or effort by the Contractor.

On the same day the project is accepted, forward the original Acceptance Letter to the Contractor and one copy each to the Region Finals Administrator, Program Engineer, Resident Engineer and Projects & Grants Accounting.

The letter should be sent by certified mail, return receipt requested, or hand delivered. If hand delivered, the Contractor should sign a copy indicating receipt. The Acceptance Letter triggers the statutory requirement of advertising for final settlement pursuant to Colorado Revised

Statutes 24-70-101. If all documentation required for finalization has not been received within 30 days, the Project Engineer should send the Contractor a written reminder.

120.3.3 Memoranda

Prepare all correspondence within the Department using a memorandum format. Memoranda should not include any logos other than the current CDOT logo, as specified by the unified state brand system. CDOT branding guidance is available at:

https://www.codot.gov/assets/2019_cdod_quickguide.pdf

120.4 FORM 105 - SPEED MEMO

Use Form 105 - Speed Memo to document:

1. directions and interpretations given the Contractor;
2. instructions to Contractor for work formalized later with a change order;
3. agreements between the Project Engineer and the Contractor; and
4. transmittal of project documents and other project information, including to the Contractor, internal CDOT staff, and consultants working on the project.

Example: For instances relating to erosion control where action needs to be taken by the Contractor, the Project Engineer should prepare and issue a CDOT Form 105 to give the appropriate direction to the Contractor for correcting the noted deficiencies and place a copy in the project file and the SWMP notebook. Failing to notify the Contractor on a Form 105 in accordance with subsection 208.09 of the Standard Specifications is being viewed by CDPHE as a non-compliance issue.

The Contractor must sign each Form 105 - Speed Memo to acknowledge receipt, even if the Contractor does not agree with its content. If a Contractor refuses to sign the form, this refusal should be noted on the form. The form should then be immediately sent to the home office address of the Contractor.

120.4.1 Use of Email Is Not an Acceptable Alternative

Email is not the established manner for CDOT project staff to communicate the information listed in Section 120.4. Therefore, the use of an email as an alternative method of documenting these communications in lieu of a Form 105 - Speed Memo is not acceptable.

An email “read receipt” or any of other form of tracking delivery or receipt of an electronic copy of a Form 105 - Speed Memo is not an acceptable alternative to obtaining a copy of a Form 105 - Speed Memo signed by the Contractor.

Additionally, in the case of the Contractor refusing to sign the form, the use of an email to deliver a Form 105 - Speed Memo is not an acceptable alternative to sending the Form 105

Speed Memo by registered mail to the home office of the Contractor. (The use of email to deliver a Form 105 - Speed Memo is an acceptable method of sending the Form 105 to the Contractor in other circumstances. The Contractor should return a signed copy to the Project Engineer) It is recommended that CDOT's use of Form 105, as detailed above, be discussed with the Contractor at the start of the project.

120.5 FORM 103 - PROJECT DIARY

The project diary should be prepared on Form 103 - Project Diary in either handwritten or electronic format. The Project Engineer is responsible for preparing Form 103. To ensure the precise recording of all Contract activities, the Project Engineer may require other CDOT personnel to prepare additional diaries. Consider the following guidelines:

1. Project Events. Document all events that occur during construction and the administration of the Contract, including:
 - a. work in progress,
 - b. labor and equipment used,
 - c. acceptability of materials used,
 - d. details of problems encountered, and
 - e. contacts with or directions issued to the Contractor.
2. Discussions. Document all discussions with Contractor personnel, property owners, CDOT Staff, and other agency personnel regarding the project.
3. Night Shift Work. Work on a night shift that begins before midnight and ends after midnight will be considered as occurring on the calendar day on which the shift ends. All documentation should be dated in accordance with this policy.
4. Audio and Video Recordings. Audio and video recordings may be used to supplement project diaries. If used, catalog the tape recordings so that they may be transcribed and indexed for future reference.
5. Standard Specifications. Figure -100-17 illustrates the minimum information related to the subsections of the Standard Specifications that should be included.

General Provisions

Subsection	Information to be Included on Form 103 - Project Diary
102.05	Prospective bidders (company and individual's name) who looked at the project, comments made, questions asked, and CDOT response.
104.02	Alteration of plans, character of work and quantities (including both anticipated and actual). Include a concise description of any changed condition, anticipated effect on Contract work underway, action required, and nature of increased work to the Contractor, including estimated time and cost to correct. Continue to document activities until the impacted work is completed.
104.03	Conditions leading to extra work.
104.04	Traffic conditions, roadway conditions, signing, flagging, detours, etc.
104.05	Use of materials found in the excavation. Conditions imposed on their use.
105.01	Directions or interpretations given to the Contractor.
105.03	Information leading to any decision on acceptance or rejection of work based on reasonable conformity.
105.09	Discrepancy in Contract documents and the decision as to which will be followed.
105.10	Objective comments on the competency of supervision and organization of Contractor. No comments should be included that could be perceived as derogatory.
105.11	Utility conflicts, status and details concerning any delay to Contract progress. Record the Contractor's effort to locate and protect utilities.
105.17	Unacceptable work - Include date and discussions leading to remedial action or rejection and ultimate resolution.
105.18	Problems concerning legal load restrictions.
105.19	Contractor efforts to maintain Contract work.
105.20	Project Engineer's action if such maintenance is not performed.
105.21	Actions taken in relation to partial or final acceptance. Include directions for completion of or correction of unsatisfactory work.
105.22	The Project Diary is the document most often referred to in the case of a Contract claim. If a claim is anticipated or has actually been started, detailed documentation covering all project activities and any impacts on the Contractor's operations should be recorded.

General Provisions

Subsection	Information to be Included on Form 103 - Project Diary
106.02	Material sources - Pit conditions before, during, and after removal of material; method of working; haul road; and any other problems noted. Contact with property owners.
106.08	Storage of Materials - Where stored, how and with whose permission. A Vested Interest Letter is required if the material is stored on private property. Record the condition of site at completion of project.
106.09	Method of Handling Materials - Damage and problems caused by transportation methods, production procedures, etc.
106.10	CDOT furnished materials. Record source, quality, cost, and handling.
106.11	Contacts made concerning non-domestic steel and actions taken.
107.01	Compliance with applicable laws. Comments by property owners or the general public.
107.10	Compliance with the <i>Manual on Uniform Traffic Control Devices</i> and the Traffic Control Plan.
107.16	Conditions and discussions related to opening portions of work to traffic, including CDOT and Contractor responsibilities.
107.17	Contractor efforts to protect work from damage.
108.01	Subcontractors working on the project.
108.03	Documentation of work progress as it relates to the Progress Schedule.
108.08	Clear statement explaining why time was or was not charged. To ensure consistency, it is recommended that only one person be designated to document weather, temperature, and other factors related to time charges.
108.10	Documentation of events leading to default of the Contract must be carefully and concisely recorded.
108.11	Documentation of events leading to termination of the Contract must be carefully and concisely recorded.
109.01	Inspection of scales and weigher certifications, as required.
109.07	Conformance to specifications and suitable storage conditions for materials on hand.

Figure 100 - 11

120.6 FORM 262 and 263 - WEEKLY TIME COUNT REPORTS

Weekly Time Count Reports (Form 262 and Form 263)

Weekly time count reports provide a weekly statement of time charges to the Contract. Time charges will be made in accordance with subsection 108.08 of the Standard Specifications, appropriate for the method used to administer the Contract. See Appendix B for examples. Consider the following guidelines:

1. Working Day. Use Form 262 - Weekly Time Count Report - Work Days if contract administration is based on workdays.
2. Calendar Day. Use Form 263 - Weekly Time Count Report - Calendar Days if contract administration is based on calendar days.
3. Fixed Completion Date. If contract administration is based on a fixed calendar date, it is not necessary to use either Form 262 or Form 263.
4. Project Diary. Ensure that the project diary (i.e., Form 103) substantiates the daily assessment of contract time, especially when less-than-full-time charges are assessed.
5. Night Shift Work. Work on a night shift that begins before midnight and ends after midnight will be considered as occurring on the calendar day on which the shift ends.
6. SiteManager®. The SiteManager® Accessories feature includes Form 262 and Form 263. Use of these computerized forms is optional.
7. Suspension of Work. When a project is to be suspended in accordance with subsection 105.01 of the Standard Specifications or when less-than-full-time charges are assessed, the justification for the action must be documented on or attached to either Form 262 or Form 263, as appropriate. The documentation must include the reason the work was discontinued and when the work is expected to resume. The justification requirements for suspension will be the same as that which would be required to support a change order to extend the project. When the Contractor requests the suspension, the Contractor must provide the required documentation to justify the suspension.
8. Contractor Refusal to Sign. Form 262 or Form 263, as appropriate, should be completed promptly and presented to the Contractor to sign and date weekly. If a Contractor refuses to acknowledge receipt by signing the form, this refusal should be noted on the form. The form should then be immediately sent by registered mail to the home office address of the Contractor. If the proposed time charges will be protested, the Contractor has 30 days to file the written protest.

120.6.1 Project Status Reports (Form 110 and Form 517)

A Form 110 or Form 517 is required for every construction project including Local Agency and enhancement projects. These forms are automatically generated.

120.6.2 Project Financial Status Report (Form 65)

120.6.2.1 Accessing Form 65 in SAP

The Project Engineer is responsible for monitoring the financial status of the project and the Project Financial Status Report (Form 65) is the tool which provides the information necessary to do this. To access the Project Financial Statement: Form 65 in SAP use transaction code ZJ20 - Project Financial Statement: Form 65. Because the Form 65 is in SAP, only CDOT employees can generate the Form 65. There are Help documents that guide you through this in the SAP Training website: <http://saptraining/>. Select Engineering then select Project Systems Lifecycle then select Project Month End/Period Close.

120.6.2.1.1 Checking Funds for a Change Order

The Project Engineer will check the Financial Statement when developing a Change Order. The steps for doing this are:

1. Maintain the Overs and Unders” report in AASHTOWare® SiteManager® Accessories, by ensuring they are up to date. This information displays in the Over/(Unders) - Inc. Bid Items, CMOs and Plan F/A line just above line [6] Total CMOs and Overs/(Unders).
2. When developing a change order, enter the planned amount for the Change Order in SAP using transaction CJR2. The Help document that guides you through this is CJR2 - Enter Planned Contract Expenditure on the Form 65.
3. Run the Form 65 Financial Statement. The planned change order amount will appear on line [9] Planned Contract Expenditure and it will adjust the amounts in Line [14], [15], and [16]. This is helpful to determine how the change order amount, CE costs and indirect charges affect the project. For further assistance, see the Help document ZJ20 - Review Planned Contractor Expenditures.
4. Review line [25] Total Cost of Project compared to the next two lines (Curr Allotment and TCA Allotment).
 - a. If line Curr Allotment and TCA Allotment are positive (+) or in surplus there is funding in your project for the change order.
 - b. If line Curr Allotment and/or TCA Allotment are negative (-) or in deficit you will need to add money to the project. Contact your Region Business office for guidance to move forward. Refer to 120.6.3.2 Requests for Additional Funds. You will use this Form 65 to justify the amount you need to add to the project.
5. To avoid accounting for the planned change order twice, this next step is crucial. You must remove the amount entered for Planned Contract Expenditure. The Help document that guides you through this, CJR2 - Remove Planned Contract Expenditure on the Form 65, is located in the SAP Training website: Select Engineering then select Project Systems Lifecycle then select Project Month End/Period Close then select CJR2 - Remove Planned Contract Expenditure on the Form 65.

6. Now you are ready to create the change order in Trans*port SiteManager® and approve. See section 120.7 of this manual.
7. You will need to manually adjust the Projected Quantities for the newly added items in Trans*port SiteManager® Accessories under the Contract Administration tab.
8. Run the Form 65. Check that line [9] is zero and that Curr Allotment and TCA Allotment are positive (+) or in surplus. The Help document that guides you through this is ZJ20 - Project Financial Statement: Form 65.

120.6.2.1.2 Maintain Form 65 for the Estimate

The Project Engineer will follow steps one and eight above to generate and check the Financial Statement monthly and submit it along with the Progress Payment Estimate from SiteManager®.

120.6.2.1.3 Adding Comments

To enter comments in the comments field at the bottom of the form, use SAP transaction CJ20N - Project Builder and in the Structure tree on the left select the Construction WBS (XXXXX.20.10). Then in the Work Area on the right click on the Long text tab and enter your comments starting in Line 2. Do not enter comments in line 1, because it is not displayed on the Form 65 and is reserved for the WBS element description.

120.6.2.2 Requests for Additional Funds

If the projected completion cost is expected to exceed the project commitment amount for the current project budget, the Region is required to request additional funding by submitting Form 1186 - Contract Funding Increase/Decrease and Approval Letter (Funding Letter) to the CDOT Controller. This submission should be made at least two weeks prior to paying an estimate that will exceed the project commitment amount. The project commitment amount is equal to the amount of the Contract (i.e., bid amount) plus the projected amount of all planned force account work.

If the projected completion cost exceeds 115 percent of the latest Transportation Commission action, the Region is required to obtain Transportation Commission approval.

For further information, see CDOT Procedural Directive 40.1 - Project Financial Status During Preconstruction and Construction. Contact the Region Business Manager or the Center for Accounting for any needed assistance. See the example and instructions in Appendix B.

120.6.2.3 Processing of Funding Letters

A funding letter must be submitted and approved before any amount that exceeds the project commitment amount can be paid to the Contractor. The Region is responsible for determining when a funding letter should be submitted on a project (see Section 120.6.3.2). A funding letter is created by completing Form 1186 Contract Funding Increase/Decrease and Approval Letter. The following procedures should be used to process funding letters:

120.6.2.3.1 Funding Letters Related to CMOs

The Construction Engineering Services Branch Construction Area Engineers will modify highway construction Purchase Orders (POs) for funding letter requests that are related to Contract Modification Orders (CMOs).

1. The Project Engineer will enter a SAP Shopping Cart, provide a draft of the CMO Form 90, a draft of the explanation letter and any pertinent attachments to the Region Business Office.
2. Upon approval of the Shopping Cart by the Region Business Office and the Program Engineer, the Business Office will submit the request, with all attachments and the funding letter, to the Construction Area Engineer and the Budget and Policy Analyst in OFMB. The Region Business Office will submit the completed funding letter to the CDOT Controller.
3. Once the CMO complies with the requirements of Section 120.7 of this Manual and OFMB concurs with the request, the Construction Area Engineer will modify the PO.

120.6.2.3.2 Funding Letters Not Related to CMOs

The Construction Area Engineers will also modify highway construction PO amendments not related to CMOs for funding letter requests for general increases or decreases. The process steps shall be as follows:

1. The Project Engineer will enter a SAP Purchase Requisition and provide documentation, including Form 65 and Overs/Unders report, as to what has changed in the project scope that requires the increase or decrease.
2. Upon approval of the SAP Purchase Requisition by the Region Business Office and the Program Engineer, the Business Office will submit the request, with all attachments and the Funding Letter, to OFMB to determine whether the change is due to a budget issue. The Region Business Office will submit the completed funding letter to the CDOT Controller.
 - a. If the change is related to justifiable cost overruns or underruns and project budget is available, the request will be immediately forwarded to the Construction Area Engineer to modify the PO.
 - b. If the change is not justifiable or there are other concerns, the request will be returned to the Region for additional clarification.
3. Upon receipt of a PO modification request that has been reviewed by OFMB, the Construction Area Engineer will proceed with modifying the PO.

120.7 CHANGE ORDERS

120.7.1 General Requirements

A change order is a construction-industry accepted term for a change in the scope, specifications, pay items, project limits, duration, or design of a project, as compared to the original Contract requirements. Change orders are legal documents that revise the terms of the original Contract between CDOT, and the Contractor Appendix C presents many examples of commonly occurring types of change orders.

120.7.2 Administrative Settlements

Every change order should be a fair and equitable agreement between CDOT and the Contractor. Change orders should not be affected by the personalities of either CDOT or Contractor personnel. Change orders at the Project Engineer/Region level must be based on a contractual basis using information to conform to Colorado Revised Statutes.

The Chief Engineer and the Region Transportation Directors are the only CDOT individuals with authority to make an administrative settlement between CDOT and a contractor. CDOT Procedural Directive 304.1, Regional Transportation Director Authority for Administrative Settlement of Construction Contract Claims, delegates authority to Region Transportation Directors (RTDs), subject to the supervision of the Chief Engineer and Executive Director of the Department. Region personnel other than the RTD cannot make administrative settlements. An administrative settlement is defined as an agreement that is not based solely on a contractual basis using factual information. The Settlement Agreement must be based on discussions with the Chief Engineer, the Area Engineer staff, RTD, the Region staff, CDOT's Controller, the Office of Attorney General (AGO), and the Office of the State Controller (OSC). The rationale for the decision should be documented in the Letter of Explanation for the resulting change order. The Chief Engineer or RTD will coordinate with the AGO to prepare the Settlement Agreement for all Administrative Settlements. Following a formal review by CDOT's Controller, all covered parties to the Settlement Agreement shall sign the Settlement Agreement, which includes the AGO, the OSC, Chief Engineer or RTD, and the Contractor in accordance with the OSC's Policy regarding Settlement Agreements. The Settlement Agreement is an attachment to the Form 90 which shall be distributed to the Contractor.

Consider the following example: The Contractor submits a request for \$100,000. The Project Engineer evaluates the request, reviews the Contract documents and is unable to support the request based on the facts and Contract requirements.

The Project Engineer considers the impacts that may result if the Contractor's request is denied, and the Contractor files a claim. The Project Engineer and his staff are busy and responding to a dispute will require a great deal of time and effort.

It will probably be necessary to hire a claims consultant to assist in preparing the claim response, which will be expensive. If the claim is not settled and arbitration is necessary, costs will increase, and additional time and effort will be required by the Project Engineer and his

staff. The Project Engineer determines that the impacts of denying this request will be significant and does not have time to prepare a dispute response.

Even though the request cannot be supported by the facts and Contract requirements, the Project Engineer makes a monetary offer to the Contractor. This is an administrative settlement regardless of the amount offered (\$1 or \$50,000) and cannot be made by Region personnel other than the RTD.

If the request cannot be supported by the facts and Contract requirements in accordance with subsection 105.22 of the Standard Specifications, the Project Engineer must deny the request. The Project Engineer should discuss denial of the request with the appropriate Area Engineer.

If a portion of the request is justified, the Project Engineer should execute a change order for the portion that is justified.

The Contractor must file a Request for Equitable adjustment to pursue the request or the portion of the request that was not justified.

120.7.3 Preparation of Change Orders

120.7.3.1 Requirements and Responsibilities

The Form 90 will be completed and shall be signed by CDOT and the Contractor prior to the start of the added or changed work. The Resident Engineer is responsible for approving all change orders. Refer to the approval requirements in section 120.7.5 and Table 120.7.5 - Order of Signatures on Form 90 for information on approvals that are required on specific types of change orders.

In some cases, time constraints may prevent the Form 90 from being completed and signed before work starts. If it is necessary to commence work before the Form 90 is completed, the Project Engineer will provide the Contractor with a written authorization to proceed. It is important that this authorization be as specific and accurate as possible to avoid further costs that may result from any confusion. The authorizing document should contain as much of the information required on the Form 90 as possible. The Project Engineer will use a letter or Form 105 - Speed Memo to issue the authorization. This authorization will be signed and routed using Adobe Sign. The authorization must describe the specific work being authorized, the basis of payment, the applicable specifications, and the method of measurement. The basis of payment will be one of the following: Contract unit prices, agreed unit prices, lump sum, or force account. When the basis of payment is agreed unit price or lump sum, the memo will include the actual agreed unit price or lump sum. The change order should be completed and executed as soon as possible.

The Form 90 - Contract Modification Order is used to document all changes to the original Contract. See Section 120.6.7 for Types of Change Orders. For change orders considered minor (Minor Contract Revision or MCR), it is acceptable to include more than one MCR line item on each Form 90.

The Project Engineer will submit a copy of the Minor Change Order Items Summary worksheet from SiteManager® Accessories to the Resident Engineer and Region Program Engineer for review on a monthly basis as the items are added to the Contract. Upon completion of the project, all Minor Contract Revision (MCR) Form 90's shall be packaged and submitted by the Project Engineer with one Letter of Explanation to the Region Program Engineer for final signature. The approved Letter of Explanation and MCR package will then be forwarded on to the Construction Engineering Services Branch by the Region Finals Administrator.

In accordance with CRS 24-30-202, the CDOT Form 90 must be “fully executed”, i.e., signed by both the Contractor and CDOT, before payment can be made to the Contractor for the change order work. Typically, the CDOT signature required to fully execute the change order would be that of the CDOT Project Engineer. In cases where there is a consultant project engineer, the Resident Engineer’s signature is required. Obtain the remaining signatures on the CDOT Form 90 and finalize the explanation letter as soon as possible thereafter.

Payment for the change order work will be made on the monthly or interim estimate as the work is completed. Barring disputes or missing documentation completed work shall be paid for monthly if the contractor is satisfactorily performing the work.

120.7.3.2 Required Information for the Form 90

The Form 90, Contract Modification Order, must be prepared in a clear and concise manner to effectively communicate to the Contractor the exact work to be performed, the applicable specifications, the basis of payment, and the impacts to contract time. Only contractual and factual information should be presented in the form 90. Form 90s will include the following information:

1. **Heading Information.** Ensure that the heading information on the Form 90 is correctly completed including the change order title block. Include “Minor Contract Revision” in the title block by selecting it from the pull-down menu if appropriate.
2. **Cost Adjustments.** Include the estimated increase or decrease in project cost associated with the change order; SiteManager automatically fills this field. The cost of a Minor Contract Revision type of change order will always be zero because added cost will be balanced against Item 700-70010 F/A Minor Contract Revisions.
3. **Opening Statements.** The use of one of the following opening statements is required on all Form 90s:
 - a. “You are hereby authorized to...”
 - b. “Your Contract is hereby modified to include...”
 - c. “Your Contract is hereby revised to...”
4. **Minimum Information.** The Form 90 must clearly describe, at a minimum, the following information:
 - a. description of work or change;

- b. location of change;
 - c. description of materials, including quantities and specifications;
 - d. construction requirements including plan and specification references;
 - e. method of measurement; and
 - f. basis of payment.
5. **Contract Time.** Ensure that contract time is properly addressed in the Form 90 and specify if the time is calendar or working days. Note that time adjustment must match the contract time type (working or calendar) in the original contract. If no time will be granted, add the statement “No additional time will be added for this work” to the form 90.
 6. **Attachments.** If attachments are necessary, ensure that each attachment contains the project number and project code and is sequentially numbered and referenced in the Form 90. If new or revised plan sheets are required, ensure that they are referenced as attachments to the Form 90 and sealed by the responsible designer, as discussed in CDOT Procedural Directive 508.1 - Professional Engineer’s Stamp. The new or revised plan sheets shall be Sealed by the responsible designer using software for electronic seals or mechanical seals

120.7.4 Statewide Uniformity

The Construction Area Engineer is responsible for providing subject matter expertise, ensuring statewide uniformity, and monitoring all change orders for completeness and conformance with established CDOT policies and procedures. The Construction Area Engineer is available for assistance with any change order but is not authorized to approve change orders. The Project Engineer will contact the Construction Area Engineer for advice and assistance on all Contract Modification Orders. The Construction Area Engineer is available to assist with all MCRs. At a minimum, the following items will be discussed:

1. circumstances precipitating the change order;
2. items of work to be included in the change order;
3. basis of payment and justification for the prices being authorized; and
4. justification of any time extensions.

120.7.5 Approval Procedures for Change Orders

120.7.5.1 Pre-approval of Change Orders

Regardless of the funding source, the Project Engineer will obtain pre-approval from the Resident Engineer before the Contractor signs a Form 90; and, upon notification, the Resident Engineer should consult with the Region Program Engineer in responsible charge of funding

decisions. The Resident Engineer must pre-approve the change order before the Project Engineer discusses it with the FHWA Area Engineer (FHWA AE).

Other approvals may also be required, as discussed in Section 120.7.7. These approvals are dependent upon the nature of the change order. For example, a structural change would require concurrence of the structural designer. A materials change would require the concurrence of the Region Materials Engineer or Staff Materials or both.

Written approval from the FHWA AE is required prior to work being performed for the following CMOs:

1. All Project Termini Extensions, regardless of oversight or funding (as defined in 23 CFR 635.102 and CDOT's Construction Manual, 120.7.7.3)
2. All changes affecting NEPA scope or Environmental Commitments
3. All Administrative Settlement of Claims
4. "Major" Design Changes on all FHWA Projects of Significant Interest (PoDI), as defined in CDOT's Construction Manual 120.7.7.1, "significant" to be determined via discussions between the FHWA AE and CDOT. Major changes on non-PoDi's are delegated to CDOT.

The FHWA approval process for these CMOs is outlined below:

1. The CDOT Project Engineer notifies the applicable FHWA AE as soon as possible of the proposed change prior to the work commencing. This is to start the early coordination between FHWA and CDOT. Upon notification, the FHWA AE will determine the appropriate level of FHWA involvement. When the FHWA AE will be signing the CMO, the following process applies.
2. The Project Engineer will submit to the FHWA AE an electronic draft of the CMO (Form 90) and draft of the Letter of Explanation, which includes a detailed description of the work, location of change, description of materials, construction requirements, method of measurement, and basis of payment including any contract time extensions, and any pertinent attachments, etc. The FHWA AE will review the CMO and supporting documentation in accordance with the "Evaluation of Change Orders" section of the FHWA procedures.
3. The FHWA AE will notify CDOT of any needed additional information or provide comments to CDOT within 5 business days. The FHWA AE shall verify that all pertinent information relating to the CMO, along with an independent cost analysis (as described in section 120.7.6.2 of the Construction Manual), is included in the submittal. The method and degree of analysis can vary by project, but it must support the final compensation determination.
4. The FHWA AE will not provide prior approval but will discuss the CMO with CDOT so that they may prepare the final Form 90 and gather necessary CDOT signatures. The CDOT Project Engineer will submit a final Form 90 to the FHWA AE for approval.

5. The FHWA AE, through signature of the Form 90 will provide formal approval of the CMO. The FHWA AE should receive the Form 90 and all attachments before the contractor performs any of the work. If the work is emergency work that must begin with the written notice from the Project Engineer (i.e., via 105), the Project Engineer shall contact the FHWA Area Engineer and their Construction Area Engineer prior to beginning such work. The Form 90 can be submitted as a PDF for FHWA signature.
6. The FHWA AE will sign the Form 90 and return the Form 90 with the original signature to the Project Engineer within 5 business days of receipt.
7. When time allows, the original Form 90 shall be routed through CDOT and FHWA to collect original signatures for final project documentation. All attachments, including the explanation letter, emails and signed PDF documents should be circulated with the original form 90 to hasten this process

<u>CDOT Project Engineer</u>		<u>Consultant Project Engineer</u>	
<u>Standard</u>	<u>PoDi/ PTE /</u>	<u>Standard</u>	<u>PoDi/ PTE /</u>
CDOT Project Engineer	CDOT Project Engineer	Resident Engineer	Resident Engineer
Contractor	Resident Engineer	Contractor	Program Engineer
Resident Engineer	Program Engineer	Program Engineer	FHWA Area Engineer
Program Engineer	FHWA Area Engineer		Contractor
	Contractor		RTD or Chief Engineer*
	RTD or Chief Engineer*		
PoDi - Projects of Division Interest			
PTE - Project Termini Extension			
*Admin. Settlement - Administrative Settlement (*only Chief Engineer)			

Figure 100 - 12

120.7.5.2 Electronic Signatures on Change Orders

Whenever possible, it is preferred to approve and route final change orders in an electronic format. The Engineer will follow the existing change order process in the Construction Manual for pre-approval and review of change orders. Adobe Sign® is required to electronically sign the CDOT Form 90, Contract Modification Order. To utilize Adobe Sign®, the person initiating signatures is required to have access to the software; however, signing documents as a recipient does not require a software license. Consultant Project Engineers may initiate the signature process with their company’s Adobe Sign license. CDOT Resident Engineers or CDOT delegates will need to initiate the signatures in Adobe Sign if the Consultant Project Engineer does not have a license.

For a single change order, mixed formats, i.e., using both electronic and hard copies, is not allowed. The final change order will be either all electronic or all hard copy.

Electronic change orders will have two PDFs (portable document format) when obtaining signatures:

1. The Form 90 and the attachments referenced in it (Form 90 Document) and
2. The Letter of Explanation and its supporting attachments (Letter of Explanation Document).

Form 90 Document

The Engineer will combine the Form 90 and its attachments into one PDF document. If the Form 90 is developed in Site Manager, print the Form 90 in PDF from SiteManager. When setting up the Form 90 PDF document and before routing for signature in Adobe Sign, check the appropriate boxes related to PoDi and Participating funds. This document is routed for electronic signature to the contractor, CDOT personnel, and FHWA personnel (when applicable) (Table 120.7.5 - Order of Signatures on Form 90). Examples of the Form 90 attachments include new or revised plan sheets or special provisions. The revised or added plan sheets also require the responsible engineer's seal before routing for signature.

Letter of Explanation Document

The Engineer will prepare a PDF of the Letter of Explanation and all supporting documentation. Typically, the supporting documents include correspondence, email, independent price justifications, schedules, Form 65, etc. that are referenced in the Letter of Explanation. The attachments to the Letter of Explanation will be sequentially numbered and referenced in the Letter of Explanation and include the Project Code and Project Number on each page. This letter is not distributed to the Contractor and does not require signatures in Adobe Sign.

120.7.5.3 Archiving Final Executed Change Order in ProjectWise

Once signed and completed the Project Engineer may combine the two documents in Adobe Sign or keep the documents separate and place the change order PDF documents in the project's Change Order folder in ProjectWise. Include the Project Code, CMO or MCR, change order number, and Form 90 or Letter of Explanation in the file name (e.g., 22391_CMO002_Form90). Also, once the change order is completely executed, email a ProjectWise link of the Change Order and its attachments and the Letter of Explanation and its attachments to the Area Engineer.

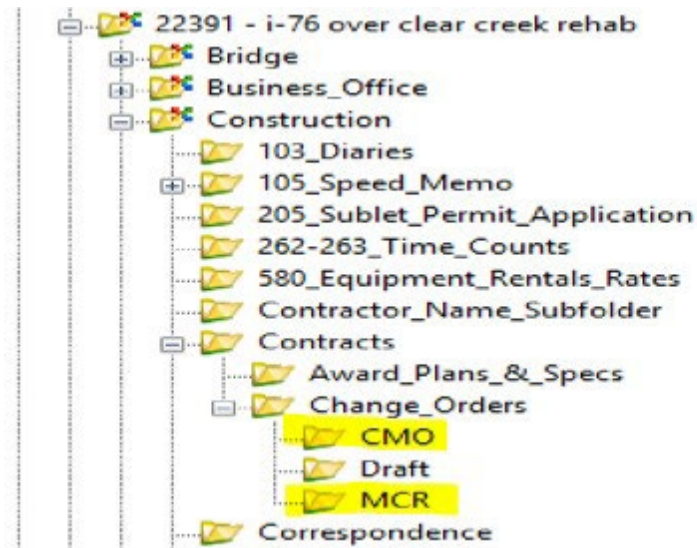

Figure 100 - 13

120.7.6 Letter of Explanation

A Letter of Explanation is required to explain and justify each Contract Modification Order. This letter is not distributed to the Contractor. The Letter of Explanation will provide the essential information to support sufficient justification.

It is acceptable to submit one letter of explanation for all of the minor (MCR Type) change orders at the completion of the project or a letter for each MCR Form 90. This letter will be drafted as MCRs are added.

120.7.6.1 Content Requirements

The Letter of Explanation must contain sufficient information for a person unfamiliar with the project to review and understand the change without additional assistance (see Appendix C). The following information must be included in the Letter of Explanation:

1. Description of Change. Provide a clear and detailed explanation of the change being made.
2. Explanatory Narrative. Provide a clear and detailed explanation of why the change is being made.
3. Measurement and Payment. Include the method of measurement and the basis of payment that will be used to pay for the work.
4. Contract Time. Explain the impact the change will have on contract time. If time will be adjusted, ensure that the letter thoroughly explains and justifies the adjustment. Time adjustments should only be made if an analysis of the project schedule determines that there is a change to the critical path of the Contractor's current approved schedule.

5. Price Justification. Include justification for each price to be paid for the work. See Section 120.7.6.2 for additional information on price justification.
6. Conversations and Concurrence. Include the dates and with whom (name and section) conversations were made and when concurrence was received from the responsible design engineer and any specialty units (e.g., Staff, Region, consultant). The Professional Engineer of Record should review and approve changes to design plan sheets. Also, include the date when the change order was discussed with the Area Engineer (see Section 120.7.4).
7. Financial Status. Describe the financial status of the project. See Section 120.7.6.3 for documentation requirements.
8. Budget Action. Include an explanation of budget action as discussed in Section 120.7.6.3, if necessary.
9. Status of Work. Include a notation regarding work status, such as “No work has started” or “Because of the emergency nature, work was authorized to commence by Form 105, dated xx/xx/xx” and attach a copy.

120.7.6.2 Price Justification

When the proposed basis of payment is an agreed unit price or lump sum, a justification for the basis of payment must be included in the Letter of Explanation for every new contract item. Federal and state statutes require that a cost justification accompany all change orders. The purpose of the cost justification is to establish or verify a reasonable cost for the work, not to determine exact costs. The price will be justified by one of the methods discussed in this Section. Contact the Area Engineer, as needed, for advice and assistance.

The price justification will be detailed. If the price justification is simple, include all the details in the Letter of Explanation. If the price justification is long or complicated, it should be summarized in the Letter of Explanation and any detailed supporting attachments included with the original copy of the change order.

120.7.6.2.1 Contractor Cost Analysis

The Project Engineer may request that the Contractor furnish a detailed cost analysis. The Contractor is not required to provide a cost analysis. To be used for price justification, the cost analysis will include breakouts of all costs for:

1. labor,
2. specific equipment,
3. material, and
4. an appropriate allocation of related fixed costs (i.e., overhead).

Fixed costs are usually offered as a percentage loading of the direct costs. A fixed cost of 15 percent or less is acceptable. A fixed cost greater than 15 percent should be analyzed for reasonableness and justified in the explanation letter.

The Project Engineer may use the cost analysis to justify an agreed unit price or lump sum, if the analysis is reviewed for reasonableness by the Project Engineer and the Letter of Explanation contains the following statements:

1. The labor and equipment hours are reasonable.
2. The labor rates and the equipment rates are reasonable.
3. The material quantities and prices are reasonable.
4. The total cost, including overhead, is reasonable.

To help the Project Engineer determine if the cost analysis is reasonable, he may use wage decisions, contractor payrolls, the Rental Rate Blue Book of Rental Rates for Construction Equipment, average equipment rates from the QC Training Manual for Construction Contract Administration, quotes from equipment rental firms and material suppliers, or other sources. The Contractor's Cost Analysis is not required to use exact numbers from any of these suggested reference sources.

For Contract changes that are considered minor (MCR), the Project Engineer need only to review the Contractor's Cost Analysis for accuracy and completeness and attach it to the Letter of justification. The Project Engineer shall include those statements described above as required for the MCR Letter of Explanation verifying that the costs have been reviewed, properly documented, and are considered reasonable. No further documentation is required to be submitted beyond what is stated here for minor (MCR) change orders.

120.7.6.2.2 Independent Cost Analysis

The Project Engineer may prepare an independent cost analysis, also called a force account analysis, to justify an agreed unit price or lump sum. The unit price or lump sum justified by this method should not exceed the total cost determined by the Project Engineer's independent force account analysis by more than 15 percent.

To help the Project Engineer estimate the costs, he may use wage decisions, contractor payrolls, the Rental Rate Blue Book of Rental Rates for Construction Equipment, average equipment rates from the QC Training Manual for Construction Contract Administration, quotes from equipment rental firms and material suppliers, or other sources. The force account analysis is not required to use exact numbers from these reference sources. The intent is to provide a simple but reasonable cost estimate.

For minor change orders (MCRs), a tiered approach for handling smaller cost changes and larger costs is acceptable. For MCRs under \$10,000 (use aggregate amount) an estimated method as shown in the following example may be used. For MCRs over \$10,000 a more detailed analysis

is required using payrolls, invoices, equipment rates following the method outlined in the CDOT Standard Specifications, subsections, 109.04(a) through 109.04(e).

Example Minor Change Order \$0 to \$10,000 - Estimated Method:

Example: Added item 603-30036 36-inch Steel End Section, Contractor submitted price \$1,200 each for 1 each. Total cost \$1,200.00. The Project Engineer’s force account analysis:

Categories			Totals
Labor:			
Laborer	4 hr X \$20/hr	\$80.00	
Operator	4 hr X \$30/hr	\$120.00	
Labor Total		\$200.00	\$200.00
Equipment:			
Combination Loader	4 hr X \$ 90/ hr	\$360.00	
Pickup	4 hr X \$50/hr	\$200.00	
Equipment Total		\$560.00	\$560.00
Materials:			
End Section	1 each X \$400/each	\$400.00	
Materials Total		\$400.00	\$400.00
Total:			\$1,160.00
A price of up to \$1,334 is acceptable.			

Figure 100 - 14

The Force Account estimate procedure as stated above shall be used only when the total dollar amount of the minor (contract revision (MCR) is equal to or less than \$10,000.

For a major contract change, a more detailed analysis is required as outlined in CDOT Standard Specifications, subsections 109.04(a) through 109.04(e). The Project Engineer shall provide all necessary documentation to justify the costs documented in the cost analysis.

Example MCR /Major Change Order Over \$10,000 - Estimated Method:

Repair to Existing MSE Wall: The Contractor submitted a lump sum cost of \$12,500.00 to repair the wall. This work includes the removal of block facing, excavation of existing material, and

General Provisions

the replacement of backfill material and blocks. Concrete slope and ditch paving will be placed to prevent further erosion.

The information below includes wage rates taken from the project Wage Decision, rounded to the nearest dollar, equipment rates from the 2007 historical data in the QC Manual, and rounded to the nearest dollar, and material rates that were quoted by the suppliers.

Categories			Totals
Labor:			
Laborer (3)	144 hr X \$18.00/hr	\$2,592.00	
Operator	48 hr X \$20.00/hr	\$960.00	
	67% loading	<u>\$2,380.00</u>	
	Labor Total	\$5,932.00	\$5,932.00
Equipment:			
Flatbed Truck	16 hr @ \$20.00/hr	\$320.00	\$320.00
Rental Equipment:			
Backhoe	6 days @ \$200/day	\$1,200.00	
	10% Loading	<u>\$120.00</u>	
	Rental Equipment Total	\$1,320.00	\$1,320.00
Materials:			
Concrete ClB	14 cu yd @ \$250.00/cu yd	\$3,500.00	
Facing Blocks	100 blocks @ \$12.00 each	\$1,200.00	
	15% loading	<u>\$705.00</u>	
	Materials Total	\$ 5,405.00	\$5,405.00
	Subtotal:		\$12,977.00
	Administrative loading per 109.04(e)		<u>\$640.00</u>
	Total:		\$13,617.00
Therefore, the contractor's submitted price of \$12,500.00 is acceptable.			

Figure 100 - 15

120.7.6.2.3 CDOT Cost Data Book

Price justification should be performed by comparing the unit prices with those documented in the latest complete year of the CDOT Cost Data Book. The CDOT Cost Data Book should be used in a statistically meaningful way. If the proposed unit price is unreasonable or significantly

greater than the average yearly unit price in the CDOT Cost Data Book, further justification must be provided. It may be necessary to review the detailed data for the item. If market prices for a particular item are volatile, it may be reasonable to use data from the current (partial) year to justify the Contractor’s submitted price.

The prices presented in the CDOT Cost Data Book are average prices. It is unreasonable to expect the price comparison to be exact prior to acceptance. It may be reasonable to accept price deviations of up to 15 percent. For example, the Contractor submits a price of \$2,350 for an inlet, but the average price in the CDOT Cost Data Book is \$2,268. This may be considered reasonable.

Comparisons can be made to selected projects based on the quantity involved or the project location, and but the rationale for the data selection will be included in the Letter of Explanation. Either average bid or award prices can be used. A weighted average will be calculated based on the selected data. It is also reasonable to consider inflation and unusual project factors. The latest full year issue of the CDOT Cost Data Book should be used for these comparisons. Consider the following example:

Example of Weighted Awarded Bid Average: Is \$350.00/LF a reasonable price for 80 LF of Item 503-00036, Drilled Caisson (36 In)?

Project No.	Description	Qty LF	X	\$/LF	=	Cost
FBR095A-011	SH95, Sheridan Bridge	76	X	\$ 205.00	=	\$15,580.00
FSA002A-005	SH2: 12 th Ave & EB I70	88	X	\$ 238.00	=	\$20,944.00
FSA0142-054	SH257 & SH14	76	X	\$ 270.00	=	\$20,520.00
NH160A-019	In Pagosa Springs	76	X	\$ 575.00	=	\$43,700.00
STA0504-066	US50B in Rocky Ford	76	X	\$ 462.00	=	\$35,112.00
		Σ 392 LF			Σ	\$135,856.00

$\$135,856.00 / 392 \text{ LF} = \$346.57 / \text{LF}$. Since the price is within 15% of calculated weighted average, \$350.00/LF is reasonable.

Note: Comparison to a single project may be acceptable if that project work is similar in nature, location, and quantity. Rationale for the comparison will be explained in the Letter of Explanation.

If a submitted price is greater than the highest of either of these averages, then the Engineering Estimates and Market Analysis Unit of the Construction Engineering Services Branch may be contacted to review the submitted price and verify that it is reasonable. The Engineering Estimates Unit may also be contacted for advice and assistance on issues such as market conditions, inflation, site-specific cost fluctuations, and guidance on analyzing cost data. The

Project Engineer is responsible for justifying the prices paid for the work; however, written concurrence and justification from the Engineering Estimates Unit will suffice for price justification and should be included with the explanation letter.

120.7.6.3 Budget Actions

The Project Engineer is required by Procedural Directive 715.1 to prepare an updated CDOT Form 65 for active construction projects on a monthly basis. This is to be reviewed by the Resident Engineer prior to the time the Interim Estimate is paid to the Contractor. Procedural Directive 715.1 also requires that no active construction project exceed budgeted funds by more than five (5) percent.

The Region Program Engineer is responsible for funding decisions, which includes signing the change order and indicating the type of funds. The Region Program Engineer must also approve all increases to the current minor contract revision limit. The date and new limit (i.e., cumulative total) will be recorded by a letter or email from the Region Program Engineer to the Project Engineer. Concurrence from the Region Program Engineer is to be obtained prior to exceeding each cumulative limit. The Project Engineer must include in the Letter of Explanation a description of the financial status of the project. The following table is made available to assist Project Engineers in addressing this requirement, and could be used in the Letter of Explanation:

(FOR EACH STATEMENT ON THE LEFT, CHECK ONE STATEMENT ON THE RIGHT)

The amount listed in PROJ'D TO COMPL column on Line [7] Project Commitment Amount*:	<input type="checkbox"/> Does not exceed approved Project Commitment Amount** - No Form 1186 required <input type="checkbox"/> Exceeds approved Project Commitment Amount** - Form 1186 Required <input type="checkbox"/> Exceeds approved Project Commitment Amount** - Delaying funding letter until the projected quantities can be adjusted accurately
The amount listed in PROJ'D TO COMPL column on Line [25] Total Cost of Project is*:	<input type="checkbox"/> <5% Over Current Allotment*** - No Budget Action is required <input type="checkbox"/> >5% Over Current Allotment*** - Budget Action is required
The amount listed in PROJ'D TO COMPL column on Line [25] Total Cost of Project is*:	<input type="checkbox"/> <15% Over Current TCA**** - No Commission Action required <input type="checkbox"/> >15% Over Current TCA**** - Commission Action is required

Figure 100 - 16

Notes:

*Add to this amount the total cost of the CMO including CE costs.

**The approved Project Commitment Amount is the sum of the Awarded Project Commitment Amount (i.e., Line 7, AWARD column of Form 65) and any approved funding letters (CDOT Form 1186 - Contract Funding Increase/Decrease and Approval Letter).

The Current Allotment is listed in Line 3, CURRENT column of Form 65. *The Current TCA (TRANS COMM ACTION) is listed in Line 26 (top right corner) of Form 65.

If the table above is not used in the Letter of Explanation, all appropriate text from the table will be excerpted and included, based on the boxes checked above. For example:

If the first line is checked in the box above, the project has a surplus, and the following statement will be included:

“No Form 1186 is required.”

See Section 120.6.3.2 for additional information.

120.7.7 Types of Change Orders

The situations presented in this Section require change orders but are not all-inclusive. Other situations may apply. Major and minor changes are processed using the Form 90- Contract Modification Order. The Resident Engineer is responsible for determining the type of change order required for the change. In addition to other criteria such as whether a change is a major design change, it is recommended that a \$25,000 limit be used for a Minor Contract Revision line item. Cost alone should not be used to determine if a change is major or minor. See Appendix C for complete examples.

Examples of Change Orders	
Type of Change	Scope of Change
Major	Major Design Changes Project Termini Extensions CDOT Field Engineering Errors Settlement of Contract Claims Changes to Traffic Control Plan (TCP) Purchase of Authorized Materials
Minor	Everything not described as Major and as determined by the Resident Engineer
Note: The Project Engineer shall consult Resident Engineer for the type of change being addressed.	

Figure 100 - 17

120.7.7.1 Major Design Changes

A Contract Modification Order is required for major design changes, including:

1. significant errors or omissions in the original design,
2. significant design features that are unsuitable for field conditions,
3. Value Engineering Change Proposals,
4. significant increase in cost, and
5. other unforeseen circumstances of a significant nature.

The Licensed Professional Engineer responsible for the design is required to stamp the new or revised design, in accordance with CDOT Policy Directive 508.1 - Professional Engineer's Stamp. The Project Engineer is responsible for incorporating the changes into the As-Constructed Plans (see Section 121.2.3).

During preparation, the Project Engineer will obtain the required concurrences before the Resident Engineer approves the change order. Depending on the nature of the change order, the following concurrences may be required:

1. Roadway Design. Major roadway design changes must have concurrence from the designer in responsible charge.
2. Structures: Where the Contractor's design is a revision to a structure in the bid plans, the organization (CDOT or consulting firm) that provided the original design shall review the contractor's proposal for the Project Engineer. The following submittal requirements shall be provided by the Contractor:
 - a. Construction plans sealed by a Colorado PE
 - b. Design Calculations
 - c. Independent design check calculations

A copy of the Contractor's proposal shall also be sent to Staff Bridge for review and archiving. This submittal shall be made to the Staff Bridge PE II assigned to the applicable Region.

3. Typical Section. Major design changes to a typical section, including changes to the subgrade, must have concurrence from the Region Materials Engineer.
4. Compaction Specification. Prior concurrence from both the Construction Area Engineer and the Materials and Geotechnical Engineer is required when a contract modification order is written to change the HMA compaction specification.

It is only necessary to note concurrences in the Letter of Explanation.

120.7.7.2 Differing Site Conditions/Significant Changes to Work

Differing site conditions and significant changes in the character of work, in accordance with subsection 104.02 of the Standard Specifications, can be complex; and the expertise of engineering staff beyond the office of the Resident Engineer and legal staff may prove to be invaluable. The Construction Area Engineer is available to provide additional advice and assistance. Consider the following:

1. Differing Site Conditions. Subsection 104.02(a) of the Standard Specifications defines differing site conditions.
2. Disputes or Claims. A dispute or claim situation may occur if the Contractor encounters conditions that differ materially from those indicated in the Contract. If the Contractor files a dispute or claim, refer to subsection 105.22 of the Standard Specifications for additional guidance.
3. Significant Changes in Character of Work. Subsection 104.02(c) of the Standard Specifications defines significant changes in the character of the work.
4. Contract Time. Subsection 108.08 of the Standard Specifications defines when the Contractor may be entitled to additional contract time.

120.7.7.3 Project Termini Extensions

The preparation and approval of a Project Termini Extension is a detailed process with very specific requirements. These procedures are stipulated in both state and federal statutes to ensure environmental regulation compliance, competitive bidding and to result in the best value for the State. It is very important that the Project Engineer follow the procedures for documentation and approval (See Section 120.7.7.3.3). The justification of extensions is carefully scrutinized to ensure that the proposal is in the best interests of the State.

In accordance with subsection 104.01 of the Standard Specifications, a Contract Modification Order is required for all project termini extensions. There are two types to consider: Type I - Routine and Type II - Critical. Both types require written approval and signatures by the Construction Engineering Services Branch Manager and the Region Transportation Director in the letter of explanation (see Section 120.7.7.3.3). For all Project Termini Extensions, regardless of oversight or funding, FHWA should be notified to determine their level of involvement. The Contractor must not sign the change order nor commence work until the CDOT and FHWA signatures have been obtained. The Project Engineer must first determine which type is applicable and note the type in the title of the change order. Evaluation criteria and approval procedures for each type are discussed in the Sections that follow.

120.7.7.3.1 Type I - Routine Project Termini Extensions

All of the following criteria must be met when processing a change order for a Type I Extension. The following items need to be addressed in the letter of explanation, in the same order as shown below, in addition to the letter of explanation requirements outlined in Section 120.7.6 (See Section 120.7.7.3.3 for additional approval requirements):

1. The Contractor is willing to do the extra work.
2. The Contractor has obtained sufficient additional bonding and insurance for the additional work.
3. The need for the work was initially established during the design process, but the work was omitted because of funding constraints.
4. The work constitutes a lengthening of the project, will be performed in a no-work section of the project, or is an added location for projects with various locations. In all cases, the work is similar in kind and nature to the original Contract work.
5. Project funds are available, and the work can be completed at reasonable unit prices.
6. Added work will be paid at Contract unit prices with minor adjustments that are considered necessary and desirable. No work will be paid by force account.
7. The total value of the proposed Type I Extension does not exceed either 20 percent of the original Contract or \$100,000, whichever is less.
8. The value of all negotiated work (i.e., work which will not be paid for at Contract unit prices) does not exceed 20 percent of the value of the added work.
9. The Region Environmental Manager has completed the necessary environmental clearances and permits and has given written concurrence.
10. The Resident Engineer, Program Engineer and pertinent specialty groups have concurred with the proposal.
11. Contact the FHWA Area Engineer to determine the level of involvement FHWA wants with this change order. If the FHWA Area Engineer will sign the Form 90, follow the procedure in 120.7.5.

120.7.7.3.2 Type II - Critical Project Termini Extensions

All of the following criteria must be met when processing a change order for a Type II Extension. The following items need to be addressed in the letter of explanation, in the same order as shown below, in addition to the letter of explanation requirements outlined in Section 120.7.6 (See Section 120.7.7.3.3 for additional approval requirements):

1. The Contractor is willing to do the extra work.
2. The Contractor has obtained sufficient additional bonding and insurance for the additional work.
3. The proposed work is in reasonably close proximity to the project.
4. The need for the work is of a critical nature for reasons of safety, structural adequacy, or design deficiency.
5. Project or other funds are available to cover the cost of the proposed work.

6. The cost of the proposed work is not expected to exceed 50 percent of the value of the original Contract.
7. Performing the proposed work as a project extension will avoid the cost of preparing plans, advertising, and awarding a separate Contract. In order to justify a project extension, these costs should be at least ten percent less expensive than if the work were bid and completed under a separate Contract. The Project Engineer will prepare a cost estimate of the anticipated total cost of the proposed work, as if it were bid and performed under a separate contract.

The Project Engineer shall submit an analysis to the Engineering Estimates and Market Analysis Unit (EEMA) of the Construction Engineering Services Branch comparing the proposed costs of the project extension to the costs if the work were bid as a separate contract. The EEMA may adjust the estimated costs to complete the work under a separate contract as necessary. If justified, the EEMA unit will concur that the anticipated cost savings to complete the work as a project extension is reasonable.

8. The Resident Engineer and Program Engineer have concurred with the proposed design and the critical nature of the proposed extension.
9. The Region Environmental Manager has completed the necessary environmental clearances and permits and has given written concurrence.
10. Contact the FHWA Operations Engineer to determine the level of involvement FHWA wants with this change order. If the FHWA Operations Engineer will sign the Form 90, follow the procedure in 120.7.5.

120.7.7.3.3 Approval Requirements for Project Extensions

1. CDOT Approval Procedures. Use the following procedures to obtain approval for change orders for project extensions:
 - a. Written approval by the Construction Engineering Services Branch Manager and Region Transportation Director is required for all project extensions.
 - b. The Project Engineer will submit to the Construction Area Engineer the full CMO package, including a Letter of Explanation illustrating that the proposed extension meets all the criteria for a project extension, including required concurrences. The request must include "I Concur" signature-approval blocks for the Construction Engineering Services Branch Manager and the Region Transportation Director in the letter of explanation.
 - c. The Construction Area Engineer will review the request to ensure it addresses all the project extension requirements and then forward the request to the Construction Engineering Services Branch Manager for signature. Once the signature is obtained, the document will be returned to the Construction Area Engineer who will send it to the Region for final signatures.

- d. The Construction Engineering Services Branch Manager and Region Transportation Director will determine that the authorization of this work will not be at the expense of an identified priority needed elsewhere in the Region or State.
2. FHWA Approval Procedures. Written approval (FHWA signature on the Form 90) may be required from the FHWA Area Engineer for either type of project extension in accordance with subsection 120.7.5 of this manual. The following are items that the Project Engineer should be prepared to discuss with the FHWA Area Engineer:
 - a. What is the reason for extending the project term?
 - b. Is the additional work programmed (i.e., included in the description of the original project or another project in the Statewide Transportation Improvement Program)?
 - c. Does an environmental clearance exist for the extra work? Either the work must be covered by the original document for the original project, or a new document must be prepared to cover the extra work. Guidance can be obtained from the Region Planning and Environmental Manager, and concurrence in any determination should be obtained from the FHWA Area Engineer.
 - d. What is the justification for not using competitive bidding?
 - e. The Region Program Engineer will make the Federal-Aid participation determination for all Federal-Aid projects after written approval has been obtained from the FHWA Area Engineer.

120.7.7.4 Contract Time Adjustments

Contract time is not automatically extended for additional work. The timing of the added change order work and how that work fits in the schedule with critical path work will determine if a time adjustment is warranted. No time adjustments will be made for work that can be completed concurrently with other work on the project.

An adjustment to contract time requires a change order and is governed by subsection 108.08 of the Standard Specifications. There are two types of change orders regarding contract time adjustments:

1. Contractor Request. If an adjustment of contract time is desired, the Contractor must forward a written request to the Project Engineer. The request must state how the work has been affected by items beyond the Contractor's control. The request must also include a schedule and supporting analysis showing how the work affected the critical path to change the completion of the project. If accepted, the Project Engineer will initiate a change order.
2. Changes in Work. Time adjustments for changes in work will be made only when a schedule analysis shows an impact on the critical path. No time adjustments will be made for work that can be completed concurrently with other work on the project. The Project Engineer must justify the time adjustment with an analysis showing how the work affects

the critical path. Record the amount of time adjustment on the change order, even if it is a zero adjustment.

120.7.7.5 Dispute and Claim Resolution

Most disputes and claims will be resolved in the Region since the Chief Engineer has delegated this authority to the Region Transportation Directors (RTD), but when the Chief Engineer resolves a claim, the Construction Area Engineer will provide sufficient information to the Region for the preparation of the change order.

120.7.7.6 CDOT Field Engineering Errors

A change order is required to correct a CDOT field engineering error and is eligible for Federal-Aid participation if the error could not have been reasonably anticipated or prevented. In addition to the requirements of Section 120.7.6, the Letter of Explanation will address the following:

1. Adequate Staffing. Include an explanation demonstrating that a sufficient number of field engineering personnel were available to fulfill the necessary construction engineering work.
2. Qualified Staff. Provide an explanation showing that the engineering personnel were sufficiently skilled and trained to understand the Contract.
3. Error Details. Provide specific information on the cause and the impacts of the error.
4. Corrective Actions. Describe the measures that were taken to prevent recurrence of a similar error.

120.7.7.7 Payment of Repairs

The Contractor shall be responsible for the maintenance and repair of all Contract items, unless the Project Engineer has relieved the Contractor of this responsibility in accordance with subsections 104.04, 105.19, and 107.17 of the Standard Specifications (see Sections 104.4, 105.19, and 107.17 of this Manual for additional information). The Contractor shall also be held responsible for damage to anything caused by his operations. If the Project Engineer grants relief from damage, a change order will be required to make payment for the damage and repairs. Consider the following:

1. Relief from Damage. CDOT will pay the Contractor for repair expenses under the following conditions:
 - a. The item damaged was not included in the Contract work, and the damage was sustained through no fault of the Contractor.
 - b. The damage to a Contract work item was through no fault of the Contractor, and the Project Engineer relieved the Contractor of responsibility in accordance with the governing Standard Specifications.

- c. The damage to a Contract work item was due to an unforeseeable cause beyond the control of and by no fault of the Contractor. See Section 107.17 for additional information on unforeseeable causes.
 - d. To qualify for relief from damage due to a foreseeable cause, the Contractor must have attempted to reasonably protect the Contract work item from the foreseeable cause of damage. See Section 107.17 for additional information on foreseeable causes and conditional protection.
 2. Letter of Explanation. In addition to the requirements of Section 120.7.6, the Letter of Explanation that accompanies the change order must include the following information:
 - a. The reason the Contractor could not have foreseen the event that caused damage to the Contract work item.
 - b. The normal precautions that were taken by the Contractor to prevent damage to the Contract work item.

120.7.7.8 Initiation or Extension of Utility Work

120.7.7.8.1 Initiation of Utility Work

When it is determined that utility work is essential to the satisfactory completion of the Contract and there is no existing agreement with the utility for the project, the following procedures must be used to authorize the utility work:

1. Notify Region Utilities Engineer. The Region Utilities Engineer will execute the new agreement with the utility.
2. Determine Reimbursement Eligibility. The Region Utilities Engineer will determine if the work is eligible for reimbursement in accordance with 23 Code of Federal Regulations 645.107, Subpart A.
3. Non-Reimbursable. If the relocation work is not reimbursable, the Region Utilities Engineer will notify the utility to commence work and explain that it will be necessary for the utility to coordinate relocation work with the Project Engineer.
4. Reimbursable. If the relocation is determined to be reimbursable in accordance with 23 Code of Federal Regulations 645.107, Subpart A, one of the following procedures must be used to accomplish the work:
 - a. Work Performed by Utility. If the utility will do the work and bill the Contractor, the Contractor and the utility must agree on the terms and conditions for performance and payment of the work. A change order between CDOT and the Contractor will be executed that authorizes the utility work. Basis of payment will be a certified invoice from the utility to the Contractor. The utility invoice will be the actual direct and related indirect costs of performing the work in accordance with established accounting procedures. Administrative compensation will be allowed according to subsection 109.04(e) of the Standard Specifications.

- b. **Work Performed by Contractor.** If the utility will allow the Contractor to perform the work and the Contractor is willing and capable, the Region Utilities Engineer will obtain a Contractor-Adjusted Utility Agreement from the utility, and the Project Engineer will execute a change order between CDOT and the Contractor to authorize the work.

120.7.7.8.2 Extension of Utility Work

If the cost of utility work will exceed the amount in the basic utility agreement, a change order is required to authorize the extension or overrun. The Colorado Revised Statutes requires a change order for every overrun or extension, no matter how insignificant. The Region Utilities Engineer is responsible for preparing the change order for the utility agreement. The date of the change order must precede the date that the work was performed. Major overruns or extensions, as determined by the Region Utilities Engineer, require a supplemental utility agreement that must be approved before the work is accomplished.

120.7.7.9 Major Change to Traffic Control Plan

A change order must be used to authorize major revisions to the Traffic Control Plan included in the construction plans (e.g., addition of a crossover).

120.7.7.10 Acceptance of Non-Specification Materials

The Region Materials Engineer and the Materials and Geotechnical Services Branch should be consulted and concur in the use of non-specification material incorporated into the work. Justification should be in accordance with Section 105.3:

1. Items without an “F” Factor (see also Section 105.3.3.1.1). A change order must be prepared for an item that does not have an “F” factor. The change order will establish either a price reduction or an “F” factor. When an “F” factor is established, the price reduction will be calculated using the price reduction formula in the Standard Specifications.
2. Items with an “F” Factor and “P” Value > 25 (see also Section 105.3.3.1.2). A change order must be prepared for items with an “F” factor that have a calculated “P” value greater than 25. The change order must establish a price reduction based on engineering judgment.

120.7.7.11 Purchase of Materials

Consider the following when processing change orders for purchase of materials:

1. **Conditions.** A change order will be required for:
 - a. a materials purchase, such as gravel for a maintenance stockpile, from a Contractor who has a Contract with CDOT; and
 - b. Contractor purchased materials that were included in the Contract but not used on the project.

2. Change Order. The change order must include:
 - a. material specifications,
 - b. location and delivery requirements,
 - c. method of measurement, and
 - d. basis of payment.
3. Letter of Explanation. The Letter of Explanation must include:
 - a. Justification. Justification for the material purchased.
 - b. Disposition. Proposed use of the material.
 - c. Account. Explanation of the account to the which the costs will be charged:
 - i. If the material can be used by Maintenance, the material should be charged to the Maintenance Section. The Region Maintenance Superintendent must give prior approval.
 - ii. If the material cannot be used by Maintenance, it must be processed as a participating cost as follows:
4. If the material can be restocked, pay the restocking charge based on the certified supplier's invoice.
5. If the material cannot be restocked, pay the Contractor for the cost of the material based on the certified supplier's invoice. The material will become the property of the Contractor or the Department, as determined by the Project Engineer.

120.7.8 Situations Not Requiring a Fully Executed Form 90

Signed Form 90s are not required under any of the following conditions:

1. Deleted or Unused Items. A change order is not required if a Contract pay item is deleted or not used, unless the Contractor is to be compensated for costs incurred before the item was deleted. The Contractor must be given written notification of the deletion.
2. Material Changes. No change order is required if the contract stipulates or allows for choices of different types of material. If the contract does not stipulate or provide for material alternatives, but the contractor proposes to change materials, this would be a change to the contract and therefore a change order would be required.
3. Price Adjustments. If a Contract formula is used to compute the price reduction for non-specification material, a change order is not required. A change order is required to accept or correct non-specification material when the "P" factor is greater than 25 (see Section 120.7.7.10 and Section 105.3).

4. Additional Items. A change order is not required to add items that are included in the Contract. Some examples include:
 - a. liquidated damages,
 - b. piling cutoffs,
 - c. supplier lien deductions, and
 - d. extra construction surveying paid in accordance with 105.13(a) of the Standard Specifications.

However, a change order is required for extra construction surveying if a rate different from that in the Contract is negotiated.

5. Force Account. A change order is not required for payment of planned force account to the Contractor unless the method of measurement or basis of payment is changed.
6. Field Revisions. The Resident Engineer will determine when a field revision constitutes a design change and requires a change order. Some examples of when field revisions do not require a change order include:
 - a. overruns or underruns of plan item quantities; and
 - b. minor adjustments to minor drainage structures, signs, fences, and walls.

Field revisions must be properly documented on the As-Constructed Plans.

120.7.9 Distribution of Completed Change Orders

120.7.9.1 General Requirements

The Region will distribute Contract Modification Orders, excluding MCR Change Orders after the Form 90 is signed by the Program Engineer and FHWA Area Engineer, where necessary. All MCR Change Orders will be submitted to Construction Services as a single document by the Region Finals Administrator after project completion. Distribution of the final change order - Form 90, letter of explanation and all attachments - is as follows:

1. Area Engineer - original;
6. Region - archived in ProjectWise Explorer in Adobe PDF/ A-1 b ISO compliant format; and
7. Contractor, excluding the Letter of Explanation.

After reviewing the change order for compliance with the requirements in this Manual and obtaining corrections from the Region, the CDOT Construction Area Engineer will distribute the original change orders, with all attachments, to the CDOT Records Center.

120.8 EMERGENCY CONSTRUCTION PROJECTS

For additional information on Emergency Construction Projects, visit CDOT's SharePoint site at:

<http://connectsp/sites/eep/SitePages/Home.aspx>

120.8.1 Definition of Emergency Conditions

Fiscal Rule 2-2 of the State of Colorado Fiscal Rules defines an emergency as follows:

An emergency is a situation that creates an immediate threat to public health, welfare, or safety, the functioning of state government, or preservation or protection of property. There is insufficient time to obtain a written waiver of the requirements for issuance of a commitment voucher pursuant to this fiscal rule before requiring goods or services to respond to the emergency.

If a situation does not pose an immediate threat to the public health, welfare, or safety, the functioning of state government, or preservation or protection of property, it is not an emergency, and these procedures cannot be used.

120.8.2 Scope of Emergency Procedures

Fiscal Rule 2-2 of the State of Colorado Fiscal Rules requires specific actions in an emergency as follows:

In an emergency, the head of an agency or institution, or his/her designee, may acquire goods and services necessary to respond to an emergency without execution of a state contract or purchase order, provided that such emergency procurements shall be made with such competition as is practicable under the circumstances. Disbursement may be made upon receipt of invoices, receipts, or other statements describing goods or services being purchased and the amount to be paid. Commitment vouchers shall be executed as soon as possible to define future performance obligations where required by the fiscal rules. As soon as practicable, and in no event later than the end of the next business day, a written report of the circumstances and the nature and value of the commitments shall be made to the chief financial officer of the agency and institution and to the State Controller.

In an emergency, only those goods and/or services that are necessary to respond to the emergency may be acquired without the execution of a state contract. Emergency procurements shall be made with such competition as is practicable under the circumstances. Once the emergency is ended, conventional contracting techniques must be used for any remaining work.

By declaring an emergency, it is recognized by the State Controller, CDOT Controller, and CDOT upper management that time is of the essence. Because time is critical, the most cost-effective procedure from a budget perspective may not be the most prudent course of action. The project manager must first focus on alleviating the immediate threat to the public health, welfare or safety, the functioning of state government, or the preservation or protection of property. The project manager must also make wise use of the state's resources.

120.8.3 Procedure for Emergencies

Fiscal Rule 2-2 grants the Executive Director the authority to obtain goods and services in an emergency without execution of a state contract. The Executive Director has delegated that authority to the Deputy Executive Director, Chief Engineer, Region Transportation Directors (RTD) and Maintenance Superintendents. Only the Executive Director or one of the delegates may declare an emergency pursuant to Fiscal Rule 2-2.

When an emergency occurs, the Region Authority (RTD or Maintenance Superintendent) should be notified of the nature of the emergency. The Region Authority will:

1. Determine whether the emergency meets the requirements of Fiscal Rule 2-2.
2. Verbally approve procurement of a contractor and commencement of work prior to execution of a contract.
3. Designate a Project Manager who is the CDOT employee authorized to acquire the resources necessary to prudently respond to the emergency. The Project Manager is also responsible for oversight of the contractor's activities.
4. No later than the end of the next business day after the emergency occurs, issue a written approval to procure a contractor and commence work prior to execution of a contract.

The Project Manager will:

1. Procure a contractor to deal with the emergency utilizing a process for the procurement that is as competitive as is practical.
2. Contact the Region Authority periodically to provide progress updates.
3. No later than the end of the next business day after the emergency occurs, submit a written request for emergency contracting to the RTD.
4. No later than the end of the next business day after the emergency occurs, submit a report to the Controller.
5. Submit contracting information to the Agreements Unit or the Procurement Office as soon as practical.

The RTD will forward the written request for emergency contracting to the Chief Engineer for approval signature. Together they will determine the limits of the emergency work and the contracting method to be used for any work subsequent to the emergency. If the Chief Engineer is not available, the request will go to the Executive Director or Deputy Executive Director.

120.8.4 Contractor Selection for Emergency Work

Commensurate with the circumstances of the emergency, the most competitive process possible should be utilized to select a contractor. The following procedures will be used:

1. Preliminary Investigation:

The Project Manager will perform the preliminary investigation and determine the best course of action. This involves determining what work needs to be done, how much needs to be done, and how it will be paid. For many emergency responses, the rapid response required, and the unknown details of the work will dictate that the work be done on a force account basis. The cost of the work can be estimated using pay items and quantities, force account analysis, or a combination of both. The following items must be determined:

- a. The scope and nature of the emergency work,
- b. Start date and time frame for completion,
- c. Pay items and estimated quantities (where appropriate),
- d. Estimated cost,
- e. Method of measurement and basis of payment.

2. Solicitation

As circumstances allow, bids should be solicited by phone or fax from at least three qualified contractors that can respond quickly. It is acceptable to solicit a bid from a contractor already working in the area. If the circumstances of the emergency, such as time constraints, limited interest, or lack of qualification makes it impractical to solicit three bids, the reason must be documented.

It is not proper to merely issue a CMO to a contractor nearby. If the work was not contemplated by the original solicitation for that contractor, then it is beyond the scope and the price agreed to in that contract. Issuing a CMO in such a situation may violate CDOT procedures and State Statutes applicable to government contract bidding. In such a situation, the work must be done under a separate contract. A nearby contractor may do the work, but a new contract would be needed for the new work.

3. Force Account Work

If force account is necessary, the work should be paid for in accordance with subsection 109.04 of the Standard Specifications. If doing so is not reasonable, then documentation must be provided explaining the rationale for exceeding labor and equipment rental rates. For example, the emergency may justify nonstop work activity for a short duration, which generally warrants higher rates. Contact the Engineering Estimates and Market Analysis Unit of the Construction Engineering Services Branch, as needed, for assistance in justifying rates.

4. Work Authorization

A written authorization on CDOT Form 105 - Speed Memo, must be given to the Contractor performing the emergency work prior to the commencement of work. The

Contractor must sign and return the authorization before proceeding. The written authorization must include the following:

- a. Scope of work and project limits,
- b. The required time to start work,
- c. Expected duration of the work,
- d. Estimated quantities,
- e. Method of measurement,
- f. Basis of payment, and
- g. Estimated total cost of the work

If payment will be by force account, include either the agreed rates for labor and equipment or the provisions of subsection 109.04, whichever is applicable.

The Form 105 must include the following statement at the end of the memo, “By signature below, the Contractor agrees to perform the work and be compensated as detailed above.”

120.8.5 Project Manager Responsibilities by the End of the Next Business Day after the Emergency Occurs

1. Written Request

The Project Manager must submit a written request for emergency contracting to the Region Authority. The written request must include the items listed below.

- a. A justification that an emergency exists in accordance with Fiscal Rule 2-2 (The explanation must be complete enough to describe the problem and how it qualifies as an emergency.)
- b. An explanation of why the normal procurement procedures will not permit procurement of a contractor quickly enough to address the emergency. (The request should state the time that will be required to obtain a contractor using the normal procurement process and why the emergency requires a quicker response)
- c. The scope of the emergency work, the limits of the project and the estimated cost.

2. Report to Controller

The Project Manager must make a report of the circumstances and the nature and value of the commitments to the CDOT Controller and to the State Controller.

120.8.6 Contracting Information

As soon as practical, the Project Manager must submit the following information to the Agreements Unit of the Construction Engineering Services Branch or to the Procurement Office, whichever is appropriate, for the preparation and execution of the emergency contract:

1. A copy of the request for emergency contracting approved by the Chief Engineer.
2. All required procurement documentation and a description of the method used to select the Contractor, including an explanation if less than three contractors were solicited, and any reasons for deviating from Department policy.
3. The basis of payment for the contract.
 - a. When the work is to be paid on an agreed unit price or lump sum basis, submit the agreed prices, units, and estimated quantities, including justification for using the agreed unit price or lump sum basis.
 - b. When force account is used, submit justification for payment in accordance with subsection 109.04 of the Standard Specifications. If the hourly rates to be paid for labor and equipment exceed those that would be paid in accordance with subsection 109.04, submit the agreed to rates and the justification for using the higher rates.

120.8.7 Contract

1. Payment Prior to Contract Signing

Disbursement may be made upon receipt of invoices, receipts or other statements describing the goods or services utilized and the amount to be paid. However, a Contract must be executed as soon as possible to define future performance obligations.

2. Preparation and Execution of Contract.

The Agreements Unit or the Procurement Office will prepare and execute the appropriate contract document as soon as practical after the emergency occurrence.

3. Administration of the Emergency Contract

4. The appropriate CDOT region will administer the Contract for the emergency work in accordance with CDOT policies and procedures.

120.8.8 Immediate Response

This procedure is to be used for immediate response to the emergency. Once the situation no longer constitutes an immediate threat to public health, welfare, or safety, the functioning of state government, or preservation or protection of property, it is no longer an emergency. Continuing work after dealing with the emergency requires evaluation of the situation and a decision of what contracting method to use for work subsequent to the emergency.

120.9 DISADVANTAGED BUSINESS ENTERPRISE FORMS

120.9.1 Form 1420

The Contractor must submit Form 1420 to request DBE goal waivers or approval of modifications to the Contractor's UP. Modifications may include commitment work area modifications, terminations, reductions, and substitutions. For substitute DBEs, the Contractor should include a Form 1415, Commitment Confirmation. Multiple requests may be included in one Form 1420. If received by the Project Engineer, this form must be submitted to the CRO. The CRO will respond to the contractor via approval or denial of the Form 1420.

120.9.2 Form 1432

The Contractor must submit a Form 1432 for each DBE that will count toward the contract goal. The Contractor should submit this form no later than thirty days from the completion of the DBE's work. The DBE completes the first set of questions, the Contractor completes the next, and the Project Engineer completes the third. The Project Engineer must send this form to the CRO. The Project Engineer should notify the CRO of any potential commercially useful function issues.

120.10 SUBLETTING OF CONTRACT WORK

Subletting of contract work will be performed in accordance with subsection 108.01 of the Standard Specifications. The Contractor may sublet no more than 70 percent of the Contract.

120.10.1 FHWA Form 1273

Item VI. 4. of FHWA Form 1273 - Required Contract Provisions - Federal-Aid Construction Contracts states the following:

No portion of the Contract shall be sublet, assigned or otherwise disposed of except with the written consent of the state highway agency contracting officer, or authorized representative, and such consent when given shall not be construed to relieve the Contractor of any responsibility for the fulfillment of the Contract. Written consent will be given only after the state highway agency has assured that each subcontract is evidenced in writing and that it contains all pertinent provisions and requirements of the Prime Contract.

On Federal-Aid projects where FHWA Form 1273 is applicable, the Contractor certifies on Form 205 - Sublet Permit Application that FHWA Form 1273 is attached to and incorporated in every subcontract and service agreement.

120.10.2 Form 205 and Form 1425

The Department assures compliance with subsections 101.61 and 108.01 of the Standard Specifications by requiring on all projects the completion, certification, and submission of the Form 1425 (Supplier Application Approval Request) and Form 205 (Sublet Permit Application). CDOT uses the Form 1425 and Form 205 to enter suppliers and subcontractors

into the B2GNow software system for prompt payment monitoring and tracking of compliance with the Disadvantaged Business Enterprise requirements. CDOT also uses Form 205 to track and oversee the subcontracting percentage. The Contractor shall complete and submit an electronic Form 1425 or Form 205 in the B2GNow system for each subcontractor and supplier on the project to the Project Engineer. The Project Engineer will recommend the supplier or subcontractor for approval in the B2GNow system. Once the Form 1425 or Form 205 receives recommended approval from the Project Engineer, the Region Civil Rights Specialist will approve or deny the supplier or subcontractor in the B2GNow system. The supplier or subcontractor may not begin work until the Form 1425 or Form 205 has been approved in the system. The Contractor must submit a revised Form 205 if items of work are added to the subcontract. It is unnecessary to revise the Form 205 for overruns and underruns. This information is used by the CRO to track Contractor compliance with good faith efforts. The Contractor must execute a written agreement with the subcontractor that includes all relevant State and Federal provisions, before the subcontractor begins work.

The following procedures should be utilized to ensure compliance with subsection 108.01:

1. Material Suppliers. Determine if the work to be performed by a firm or individual is part of the construction Contract or is supplying material using the definitions outlined Specification 101.81 and 101.81.5. The Form 205 is not required for suppliers. Instead, the Contractor must submit a Form 1425 for each supplier that meets the \$10,000 threshold outlined in 106.01. Supplier employees, including truck drivers, are not covered by DBRA prevailing wages in the following instances (the prevailing wage requirements do not apply to these employees and are not included on a payroll):
2. Employees working at and truck drivers hauling to the project from a facility not deemed part of the “site of the work” are not covered under DBRA prevailing wage requirements. The facility is not considered to be part of the “site of the work” if it does not meet the criterial of dedicated and/or adjacent to the project.
 - a. For example: If truck drivers are hauling material to the project from a facility that is not adjacent or virtually adjacent to the project, they are not covered under DBRA.
 - b. For example: Truck drivers hauling materials to the project from a commercial source are not covered under DBRA. The commercial source is not a facility that is dedicated exclusively, or nearly so, to the project; Therefore, DBRA does not apply.
 - c. Trucking owner-operators are not covered under DBRA.

For drivers that work (either as employees or contractors) for a bona fide material supply company the following additional guidance applies. If the driver is making deliveries of materials to the site of work, that time is not covered for DBRA purposes. However, if the worker of a material supply company (including a driver) performs actual construction work (such as warranty or repair work) for more than an incidental amount of time (20% of a work week), and that construction work is related to an item that has been delivered to

the site of work, then that time spent performing actual construction work (on site) would be covered by DBRA. Moreover, if a worker for a material supply company spends more than 20% of their workweek performing actual construction work on the site of work, at that point all time that the worker spends on the site of work, including delivery time, will be considered to be covered. The material supply company should be tracking any time that a material supply company worker spends on the site of work doing actual construction to make sure that the worker is paid the applicable prevailing wage for that work. If the material supply worker spends more than 20% of their work week performing actual construction work, the contractor would then also need to track delivery time spent on site as at that point they are considered to essentially be a construction worker and all of their onsite time would be covered.

1. Subcontractors. If a firm or individual subcontractor performs the work, a written subcontract, approved Form 205, and certified payrolls are required, subject to the following conditions:
 - a. Owner/Operator Truck Drivers. The U.S. Department of Labor takes a non-enforcement position on drivers who own their own trucks, thus Davis-Bacon wages are not required. An owner/operator is defined as an owner driving a truck that is registered in the owner/operator's name. Truck drivers who are owner/operators must appear on a certified payroll. The owner/operator's name, address, and Social Security number must be included on the payroll with the notation "owner/operator" listed under the wages column. Owners of other types of equipment must comply with Davis-Bacon requirements. Contractors shall:
 - i. submit Form 205 for the owner/operator and have the owner/operator certify and submit its own payroll.
 - b. Truck Drivers and Site of Work Considerations. Truck drivers who are not on site haulers (hauling on the site of work, from the site of work, or to the site of work) are not covered by the requirements of the Davis-Bacon Act. The Department recognizes the following definition of site of work: Site of Work: The site of work shall be defined as the physical location where the project exists and any adjacent property that is set up to service the project. If the staging area, pits, or plants can be accommodated on the project site or on adjacent property, but are located elsewhere for circumventing the payment of predetermined wage, the site of work shall include the service area. For the purposes of determining site of work, adjacent shall be defined as "lying near or close to; sometimes, contiguous; neighboring. Adjacent implies that the two objects are not widely separated, though they may not actually touch." Project Engineers should contact their Region Civil Rights Office for assistance in making determinations.

- i. For drivers that work (either as employees or through a written agreement) for a construction contractor (or subcontractor) performing construction onsite, the following additional guidance applies. Under current DOL guidance as stated in the Field Operations Handbook at 15e22, drivers who work for the construction contractor are covered when loading or unloading materials onsite for delivery or removal if such time is not de minimis, such as just a few minutes spent at a time to pick up or drop something off. Waiting in queue on the site of work to drop off materials from a location that is not on the site of work does not contribute to the few minutes. There is no 20% requirement or cutoff for determining that work is or is not de minimis for truck drivers who work for contractors. In the Field Operations Handbook, the 20% is only mentioned with reference to drivers who work for material supply companies.
 - c. Other Truck Drivers and Construction Personnel. All other truck drivers and construction personnel are covered by Davis-Bacon requirements and must appear on certified payrolls in accordance with the following:
 - i. a written subcontract and completed Form 205 must be executed, and the truck drivers or equipment operators must submit their own payroll.
- 2. Subcontractors that are also material suppliers on a single project: Per Specification 108.01, when a firm both sells material to a prime contractor and performs the work of incorporating the materials into the project, these two phases shall be considered in combination and as constituting a single subcontract. The Subcontractor shall acknowledge on the Form 205 that they are operating both in the capacity of a Subcontractor and Supplier for a project.
 - a. Certified Payroll considerations: When evaluating whether certified payrolls are required, the primary employer will evaluate what functions the employee is doing on the site of work. If the employee is performing active construction as part of the subcontracted work, the employee will be subject to the Subcontractor certified payroll guidance above.
 - i. If the employee in the capacity of fabricating or processing an item off the site of work or is delivering an item(s) to the site of work, they are acting as a supplier and will be subject to the Supplier certified payroll guidance in the Supplier section below.

120.10.3 Use of Form 205 for Leased or Rented Equipment

The following information defines the requirements for using Form 205 for leased or rented equipment:

1. Operators on Payroll. If the Contractor or subcontractor rents or leases equipment, Form 205 - Sublet Permit Application is not required if the operator:
 - a. is considered part of the Contractor or subcontractor organization, and
 - b. will appear on the Contractor or subcontractor payroll.

This criterion applies whether or not an operator is supplied with the equipment.

2. Operators Off Payroll. If the Contractor or subcontractor rents or leases equipment with an operator, Form 205 is required if the operator:
 - a. is not considered part of the Contractor or subcontractor organization, and
 - b. will not appear on the Contractor or subcontractor payroll.

The equipment subcontractor must have an approved Form 205, and the operator must appear on the equipment subcontractor payroll.

3. All Projects. On all projects, all employees performing the contract work must appear on a payroll and be paid at least the predetermined minimum.

This applies regardless of:

- a. who rents or leases the equipment;
- b. whether the equipment is rented or leased, with or without an operator; or
- c. whether or not the equipment or operator are considered part of the Contractor or subcontractor organization.

120.10.4 Review, Approval, and Distribution of Form 205

120.10.4.1 Project Engineer Review

The Project Engineer will check the following items before recommending the Form 205 - Sublet Permit Application for approval to route to the CRO:

1. Partial Items. If partial items of work are sublet (e.g., the "Drive Only" portion of a bridge piling item), the percentage of the Contract unit price that is being sublet must be placed in the percent of original bid price column.
2. Other Checks. Check that all Contract unit prices, extensions, totals, and percentage calculations are correct.

120.10.4.2 Project Engineer Approval

The Project Engineer will recommend the Form 205 for approval in the B2Gnow system, which constitutes approval to sublet portions of the Contract.

120.10.4.3 Region EEO/Civil Rights Specialist Review

The following items are the responsibility of the CRO.

1. Debarment and Suspension. Check all proposed subcontractors for debarment or suspension. A list of Federally debarred Contractors, CDOT-debarred, CDOT suspended Contractors, and interlocking ownership Contractors is available at <http://www.arnet.gov/epl>. Form 205 will not be approved if a Contractor has been debarred or suspended or there is reason to believe such action is being considered. The CRO will immediately notify the Project Engineer and the Construction Engineering Services Branch Manager. For additional assistance, call (303) 757-9540.
2. Disadvantaged Business Enterprise Goals. For DBEs listed on the Contractor's Utilization Plan, verify the work listed on the Form 205 matches the work listed in the DBE commitment and the DBE is still certified to perform the work. If the Contractor is adding a new DBE for credit, verify the DBE is certified to perform the work and, if the Contractor is adding a supplier, the work has been properly counted. If the subcontractor is not a DBE, verify that the participation does not conflict with the utilization plan.
3. Approve Form 205 in B2Gnow: The CRO will review the Form 205. If approved, the Form 205 will be available in the B2Gnow system. The CRO and Project Engineer have access to view the record in the system.

120.10.5 Replacement of Subcontractor

If it is necessary to replace a subcontractor that is a certified Disadvantaged Business Enterprise, the Contractor must follow the procedures in the Standard Special Provisions included in the Contract.

120.11 PROGRESS SCHEDULE/METHODS STATEMENT

The Contractor is required to submit methods statement and progress schedules in accordance with subsection 108.03 of the Standard Specifications.

120.11.1 Progress Schedule

Consider the following guidelines when processing progress schedules:

1. Purpose. The progress schedule is used to evaluate the potential for modifying contract time, in accordance with subsection 108.08, and to evaluate disputes and claims, in accordance with subsection 105.22.
2. Submittal. The Contractor shall submit either the bar chart or the critical path method 90-day project schedule at least five working days prior to the start of work.
3. Review and Acceptance. The Project Engineer will carefully review the schedule and either return it to the Contractor for revision or provide initial written acknowledgment of receipt. No schedule will be accepted that shows completion of work after the

authorized number of workdays or the specified fixed completion date of the Contract. If the Critical Path Method is used, no work will be permitted beyond the first 90-day period until the project schedule has been submitted and accepted. On large complex projects with a potential for claims, the Project Engineer may want to utilize a non-project specific claim consultant contract administered by the Construction Engineering Services Branch to assist with schedule reviews.

4. Schedule Updates. As the work is prosecuted, the Contractor shall prepare and submit monthly progress schedules that reflect the actual work performed. Progress payments will not be processed if the progress schedule has not been received by the Project Engineer on or before the payment cut-off date (see Section 109.6.1).
5. Lagging Schedules. If it appears that the actual progress is significantly lagging, the Project Engineer will forward written notification to the Contractor requesting submittal of a schedule that shows how the project will be completed on time. The Project Engineer will withhold progress payments if the Contractor fails to furnish the revised schedule within 15 days of receiving the written request.

120.11.2 Methods Statement

The methods statement is a narrative description of all work necessary to complete each salient feature. See subsection 108.03 of the Standard Specifications for formatting requirements. The methods statement will be submitted with the progress schedule at least five days prior to the start of work. The Project Engineer should review the methods statement and either return it to the Contractor for additional information or provide written acknowledgement of its receipt. Appendix B illustrates an example. Note that all information contained in the methods statement is proprietary and must be kept confidential.

120.12 MATERIALS

The requirements for materials documentation are presented in the CDOT Field Materials Manual. The Project Engineer must comply with the documentation requirements.

120.12.1 Nuclear Gauges

Chapter 800 of the CDOT Field Materials Manual, Documentation Chapter, addresses the proper use and storage of nuclear gauges that are used to perform various materials testing. A radiological monitoring device must be worn by all personnel that operate testing equipment with a nuclear source (i.e., moisture/density gauge, asphalt content gauge), in accordance with CDOT Procedural Directive 89.2 - Medical Monitoring for Hazardous Materials Workers. See Chapter 800 of the CDOT Field Materials Manual for additional guidance.

120.12.2 Field Laboratory Test Results

If material test results are found to be outside specified limits, the Contractor should be immediately notified using Form 626 - Field Laboratory Test Results. This will enable the Contractor to take corrective action in a timely manner to address non-complying materials. Form 626 is normally prepared by the Project Materials Tester, signed, and dated by the Project

Engineer, and presented to the Contractor for acknowledging signature. The completed and signed Form 626 is distributed to the Contractor, Project Engineer, and the Project Materials Tester.

120.12.3 Calculation for Price Reduction

When the materials furnished, the work performed, or the finished product does not conform to the Contract, the material or work will be evaluated for price reduction according to subsection 105.03 of the Standard Specifications. Use the latest version of the price reduction software to perform the calculations. Check the data input carefully. Include the printout in the final pay quantity documentation and enter the price reduction on the pay estimate as a negative dollar amount. Record the out of specification material on the appropriate materials summary report and attach a copy of the printout from the price reduction software.

120.12.4 Concrete Batch Plants and Trucks Mixer Certification

120.12.4.1 Truck Mixer Certification

The Contractor is required to obtain certification from the concrete supplier that truck mixers are acceptable based on the requirements defined in subsection 601.07(c) of the Standard Specifications. Form 46 - Concrete Truck Mixer Inspection Certification will be used to document this information and certify all trucks to be used on the project. See Appendix B for a sample Form 46. This certification shall be completed whenever the Contractor purchases a mixer truck. The Contractor shall provide the Project Engineer with a copy of this certification with the correct date and current project number for each project. The Contractor will be required to complete a new certification only if flights are changed and the wear marks are different than when the original certification was completed. Ready Mix supplier signature approval is required. During the project, spot checks of truck mixers should be performed and documented in the project diary.

120.12.4.2 Batch Plant Certification

Prior to initiating concrete placement, the Project Engineer will ensure that the batch plant has current scale and water-meter certifications. The condition of batching equipment and material storage areas should also be inspected for compliance in accordance with the requirements defined in subsections 601.07 and 106.08 of the Standard Specifications, respectively. Record this information in the remarks section of Form 46 - Concrete Truck Mixer Inspection Certification or in the project diary.

120.13 CONFERENCES

Section 120.13 discusses several types of conferences that are typical of CDOT construction projects. Appendix A presents sample conference agendas that may be used “as is” or as a guide in developing customized agendas for the Region or project.

120.13.1 Preconstruction Conference

120.13.1.1 Purpose

As soon as practical after a Contract is awarded, the Project Engineer will arrange a Preconstruction Conference with the Contractor to discuss the prosecution of work. The Preconstruction Conference is a good opportunity to review with the Contractor the Department's expectations and the details of the project before construction begins.

120.13.1.2 Notification Letter

A Preconstruction Conference Notification Letter should be prepared and forwarded to the Contractor. The letter should include the meeting date, time, and location, and an itemized list of all information and documentation that CDOT needs from the Contractor before the conference and the date this information is due. Ensure the due date provides the Department with sufficient time to adequately prepare the conference agenda. See Appendix A for examples of both letter and fax notifications.

120.13.1.3 Preconstruction Conference Agenda

The Preconstruction Conference should follow a carefully prepared agenda, similar to the example presented in Appendix A. Emphasize at the Preconstruction Conference that, regardless of who is responsible for the cost of repair or maintenance, both CDOT and Contractor personnel are responsible for ensuring that all dangerous situations are immediately corrected. Prompt notification of the Project Engineer and correction by the Contractor are important. Long lead items should be noted during the conference.

120.13.1.4 Distribution of Meeting Minutes

After the Preconstruction Conference, a completed copy of the agenda and the minutes of the meeting should be forwarded to each attendee, including the FHWA Operations Engineer for all projects with Federal oversight.

120.13.2 HMA Pre-paving Conference

Paving operations on projects that will use large quantities of asphalt paving material should be coordinated by the Project Engineer prior to starting the paving operation. A Pre-paving Conference that involves all affected parties should be scheduled so that critical elements of the paving operation (e.g., traffic control) can be discussed and resolved before the operation begins. The meeting should be facilitated using a Conference Agenda similar to the one presented in Appendix A for the HMA Pre-paving Conference. After the conference, a completed copy of the agenda and the minutes of the meeting should be forwarded to each attendee, including the FHWA Operations Engineer for all projects with Federal oversight.

120.13.3 Concrete Pavement Pre-paving Conference

The Project Engineer should conduct a Pre-paving Conference before concrete paving operations begin. Attendees should include all parties involved in the work. The meeting should

be facilitated using a conference agenda similar to the one presented in Appendix A for the Concrete Pavement Pre-paving Conference. After the conference, a completed copy of the agenda and the minutes of the meeting should be forwarded to each attendee, including the FHWA Operations Engineer for all projects with Federal oversight.

120.13.4 Structural Concrete Pre-pour Conference

The Project Engineer should conduct a Pre-pour Conference prior to placement of significant quantities of structural concrete on the project. Attendees should include all parties involved in the work. The conference should be held prior to placement of concrete for major structures, particularly bridge decks. The meeting should be facilitated using a conference agenda similar to the one presented in Appendix A for the Structural Concrete Pre-pour Conference. After the conference, a completed copy of the agenda and the minutes of the meeting should be forwarded to each attendee, including the FHWA Operations Engineer for all projects with Federal oversight.

120.13.5 PC/OA Conferences for Asphalt and Concrete Pavements

The PC/OA specifications provide for incentive/disincentive payments, and it is important that Contractor process control personnel and CDOT Quality Assurance personnel understand their respective duties and responsibilities. As such, a PC/OA Conference should be held prior to beginning each paving project governed by PC/OA specifications. The PC/OA Conference may be held simultaneously with the Pre-paving Conference. The meeting should be facilitated using a conference agenda similar to the samples presented in Appendix A for hot-mix asphalt and concrete pavements. After the conference, a completed copy of the agenda and the minutes of the meeting should be forwarded to each attendee, including the FHWA Operations Engineer for all projects with Federal oversight.

120.13.6 Pre-survey Conference

The purpose of the Pre-survey Conference is to discuss the construction surveying and survey monumentation requirements of the project and to coordinate schedules. This meeting will be held prior to commencing survey work, and the CDOT Survey Manual includes sample agendas to facilitate the meeting. Attendees generally include Superintendent, Survey Party Chief, Professional Engineer or Land Surveyor in responsible charge of the survey work, Project Engineer, Project Survey Inspector, and Region Survey Coordinator. After the conference, a completed copy of the agenda and the minutes of the meeting should be forwarded to each attendee, including the FHWA Operations Engineer for all projects with Federal oversight.

120.14 PIT PAYMENTS (Royalty Fees)

120.14.1 Physical Pit Condition Certification

If CDOT holds the "Option to Buy Material," a Form 789 - Physical Pit Condition Certification will be used to document the pit owner's final acceptance of the physical condition of the pit, as required by the Contract. Form 789 should be completed, and the owner's acceptance signature

obtained by the Project Engineer as soon as practical after completion of the work in and around the pit site. A copy of Form 789 will be submitted to the Records Center.

120.14.2 Mining Permits

If the Contractor uses material from any source, the Contractor is required to furnish the Project Engineer a mining permit from the Mined Land Reclamation Division or a letter from the Mined Land Reclamation Division stating that no permit is required. This must be accomplished before the material is excavated. If the source is an available source for the specific project and CDOT holds a current mining permit, no further action will be required by the Contractor.

120.15 INTERIM CONTRACT PAYMENTS

Section 120.15 provides recommended procedures for documenting the method of measurement and basis of payment for interim pay estimates. Documentation may be provided on either hard copy or electronic forms. See Section 121 for information on documenting final pay estimates. Contractors or subcontractors can access the pay estimate at <https://www.codot.gov/business/engineeringapplications/project-construction/aashtoware-project-construction-sitemanager-pay-estimates#gsc.tab=0>. The user is “contractor” and the password is “prompt pay”.

120.15.1 Documentation for Contract Pay Items

120.15.1.1 General

Documentation of the various pay items included in the contract shall be done in the SiteManager® Daily Work Report (DWR). Additional documentation may be prepared using CDOT numbered forms electronically attached to the DWR’s or appropriately referenced in the DWR as described in Section 120.1.3.5. Other supplementary documentation shall be electronically attached to the DWR or appropriately referenced in the DWR as described in Section 120.1.3.5. Hardbound field notebooks shall not be used for pay item documentation due to the large volume of irreplaceable documentation that would be lost if a field book were destroyed or misplaced. The project diary will not be used to document pay items.

120.15.1.2 Quantity and Payment Considerations

The Project Engineer is required to approve all progress payments based on the interim quantities documented during the prosecution of work. Two documentation methods may be used, and the method selected for each pay item should minimize the time required to prepare and submit final quantities:

1. Method One - Measured or Counted Quantities. Method One will be used for pay items that can be measured or counted as the work progresses. The source document will be used to support payment of actual quantities as the work is performed. Quantities of this type will be entered in the Daily Work Report in SiteManager® and automatically posted to the Item Summary.

2. Method Two - Estimated Quantities. Method Two should be used when the actual quantity of the pay item cannot be determined as the work progresses (e.g., earthwork). The source document will be used to support payment of estimated quantities. Interim measurements will be entered in the Daily Work Report in SiteManager® and automatically posted to the Item Summary. If Method Two is used, the final quantity of the pay item will be measured as indicated in the Specifications.

The term, “estimated quantity”, means a quantity that is calculated approximately. It is the Project Engineer’s responsibility to calculate estimated quantities as accurately as possible so as not to overpay the Contractor. Consider the following:

Load counts may be used to verify estimated quantities; however, they are not a substitute for actual measurements and shall not be used alone to justify interim payments. Interim surveys or quantities calculated based on cross section estimates may be used to support earthwork payments.

120.15.2 Methods of Measurement

Figure 100 - 18 illustrates methods of measurement for interim and final pay item quantities. This table is a guide. Refer to the Plans and Specifications for additional information.

ITEM TYPE	INTERIM	FINAL
201 - Clearing and Grubbing	Percent of lump sum.	Item is complete. If lump sum, include beginning and end dates.
202 - Removals	If lump sum, a percent of lump sum.	The total of the removal, whether a counted item, measured item or lump sum.
203 - Excavation and Embankment	Based on a calculated estimated quantity.	Plan quantity unless changes or errors are found.
206 - Structure Excavation/Backfill	A percentage based on the plan quantity.	Plan quantity unless changes or errors are found.
207 - Topsoil	A percentage based on the original calculations.	Measured quantity pursuant to SS 207.04
208 - Erosion Control	Actual amount used.	Actual amount used.
209 - Watering	Actual amount used based on approved meters or measured in the vehicle at the point of delivery.	Actual amount used based on approved meters or measured in the vehicle at the point of delivery.
210 - Resets	A percentage based on the whole amount.	Item is complete. Actual quantity completed.
212 - Seeding and Fertilizing 212 - Sodding	A percentage based on the plan quantity.	Plan quantity unless changes or errors are found.

ITEM TYPE	INTERIM	FINAL
213 - Mulching	A percentage based on the plan quantity.	Plan quantity unless changes or errors are found.
214 - Planting	Actual amount placed.	Actual amount placed.
215 - Transplanting	Actual amount placed.	Actual amount placed.
216 - Soil Retention Covering	Actual amount placed.	Actual amount placed.
217 - Herbicide Treatment	Actual amount measured.	Actual amount measured.
300 - Bases	Total quantity placed.	Total quantity placed.
400 - Pavements	Total quantity placed.	Total quantity placed based on certified scale tickets or measured quantity as applicable.
500 - Structures	Percent of plan quantity.	Plan quantity unless changes or errors are found.
500 - Piling	Actual measurements of piling and any welds.	Actual measurements of piling and any welds.
626 - Public Information Management	Actual amount used.	Actual amount used.
630 - Traffic Control Items	Payment per specification.	Final measurement or count.

Figure 100 - 18

120.15.3 Force Account Work

120.15.3.1 Definition

A force account is a time and materials method of payment based on established hourly rates and the quantities of labor, materials, and equipment that are used to complete the work.

120.15.3.2 Force Account

A force account should only be used when the Project Engineer and the Contractor cannot agree on an agreed price for the work (i.e., unit or lump sum), or the nature of the work is such that it is not possible to determine an agreed price. The Department discourages the use of force account because it increases the costs to the Department and removes the Contractor's incentive to efficiently complete the work. This is an especially important consideration for work involving large amounts of money.

120.15.3.3 Importance of Converting Force Account to Fixed Price

If a force account is currently in effect, the Project Engineer should be monitoring the work for an opportunity to convert this time-and-materials method of payment to one that is more

suitable to the Department (i.e., agreed price). At some point during the work, a force account can often be converted to an agreed price, because both the Project Engineer and the Contractor have a better understanding of the scope and costs involved. Unless the estimated cost is less than \$2,000, the Project Engineer should attempt to negotiate with the Contractor to determine if an agreement can be reached on an agreed price for the remaining work. If such an agreement can be reached, payment should be made as follows:

1. Payment for Work Already Completed. The work already completed will be paid for as force account.
2. Payment for Remaining Work. Reimbursement for the remaining work should be paid for at the agreed price (i.e., unit price or lump sum).

120.15.3.4 Initiating Force Account Work

Force account work that is not already included in the Contract (i.e., planned force account) must be authorized by a change order. The added item code should begin with a “700” prefix. Force account work is administered differently than other pay items. The Project Engineer, not the Contractor, is responsible for directing the work. Before force account work begins, the Project Engineer must discuss with the Contractor and reach agreement on many work-related issues. Although this will be performed in a cooperative manner, the Project Engineer is authorized to make all final decisions regarding the work. Consider the following guidelines:

1. Scope of Work. Discuss the scope of work to ensure that the Contractor fully understands what the work is to accomplish, including limits, expectations, and acceptance.
2. Construction Methods. Discuss with the Contractor the most efficient construction methods and procedures available to complete the work and emphasize that the work is to be performed in an efficient manner.
3. Efficiency Improvements. Both the Project Engineer and the Contractor should continually monitor the progress of the work to determine if better methods are available to improve efficiency and reduce costs. In reality, such analyses will be the primary responsibility of the Project Engineer; and, where improvements can be made, the Project Engineer is authorized to require changes to the Contractor’s operations.
4. Conversion to Unit Pricing. Similar to efficiency improvements, both the Project Engineer and the Contractor should continually monitor the operation for the opportunity to convert the force account to unit pricing. In reality, such an effort will be the primary responsibility of the Project Engineer. See Section 120.15.3.2 for additional information on this topic.
5. Labor Issues. Discuss with the Contractor the most efficient use of manpower available to complete the work. If practical, utilize workers that is available on the project. In most cases, this will be the most efficient procedure, but ensure that it does not adversely affect the prosecution and progress of other Contract work. In addition, ensure that the Contractor has a clear understanding of the number and classification of workers required (e.g., four laborers, three operators, and one foreman) and the number of hours to be worked each day.

6. Materials. Discuss with the Contractor the material issues related to the force account work, including:
 - a. required types,
 - b. available sources,
 - c. quantities and rate of use,
 - d. pricing, and
 - e. acceptance criteria.

7. Equipment. Discuss with the Contractor the most efficient use of the equipment available to complete the work. If practical, utilize equipment that is available on the project. In most cases, this will prove to be the most efficient, but may warrant a cost comparison to mobilizing equipment that is more efficient. The quantity of work will be a major consideration in this analysis. For example, if required only for a few hours, equipment available on the project may be the best choice, even if efficiency is discounted. However, if required for several weeks, it would probably be prudent to consider mobilizing equipment that is more efficient. Ensure that Contractor clearly understands what is required with respect to:
 - a. owned, leased, or rented equipment and any mobilization required;
 - b. equipment type (e.g., scraper, backhoe, haul truck);
 - c. size of equipment (e.g., five cubic yard, 15 cubic yard);
 - d. number of each equipment type required (e.g., one each, 20 each);
 - e. starting date required for each type of equipment; and
 - f. the hours the equipment is required each day.

120.15.3.5 Form 10

Force account work will be recorded daily on Form 10 - Inspector's Report For Force Account Work and it is the source document for the pay item. Several key pieces of information must be recorded, and the preparation of Form 10 must be thorough. Consider the following when preparing Form 10:

1. Form Capacity. Form 10 has sufficient space to record five days of force account work. The dates recorded do not have to be consecutive.
2. Signature Approval. At the end of each workday, representatives of the Contractor and/or subcontractor must initial the daily record that has been documented on the Form 10.
3. Employee Names. Employee names must be recorded as they appear on certified payrolls, either Contractor or subcontractor.

4. **Equipment Data.** The following information must be recorded on Form 10 for each piece of equipment used for the force account work:
 - a. description;
 - b. equipment number from Form 580;
 - c. equipment disposition (i.e., designated operation or on standby);
 - d. hourly equipment rental rate from Form 580; and
 - e. hours the equipment was used.
5. **Supporting Information.** Supporting information related to work progress, conversations with the Contractor, decisions, and any problems encountered should not be recorded on Form 10, but should be documented in the Project Inspector's diary (i.e., Form 103).

Upon completing Form 10 (i.e., five days of force account work entries), a copy should be forwarded to the Contractor. The Contractor shall use the copy of Form 10 to prepare the billing for the force account work. See Appendix B for a sample Form 10.

120.15.3.6 Form 580

Form 580 - Equipment Rental Rate Determination Request will be used to calculate equipment rental rates and must be retained with the force account documentation. Ensure that all required information is provided. See Appendix B for detailed information on completing the form.

120.15.3.7 Standby Equipment Rental Rates

As approved by the Project Engineer, standby equipment rental rates will be used to reimburse the Contractor for ownership costs and will be based on the Rental Rate Blue Book for Construction Equipment. Contact the Region, as needed, for assistance in determining these rates. Consider the following guidelines before approving use of standby equipment rental rates:

1. If the equipment is idle because of a mechanical failure, there is no obligation for reimbursement.
2. If the equipment is used for other non-force account work, standby rates should not be used.
3. If equipment has been ordered available for work but is idle through no fault of the Contractor, standby rates should be used.
4. If the cost for holding the equipment on site is less than the cost for removal and remobilization, standby rates should be used.

5. If equipment is not mobilized under its own power, reimbursement will include the standby rate for mobilization, including disassembly and reassembly, if applicable; and the hauling unit rental rate.
6. Standby rates are not applicable to small tools.

120.15.3.8 Reimbursement for Leased or Rented Equipment

The Contractor will be reimbursed for leased or rented equipment as follows:

1. **Actual Costs.** If the cost can be substantiated by a certified invoice, the Contractor will be reimbursed for the actual cost of leased or rented equipment. It is possible for the hours on the invoice to differ from those on Form 10. For example, the Contractor may have had to pay for a minimum of eight hours, even though the piece of equipment was only used for six. The Contractor will be reimbursed for the actual cost of the eight hours.
2. **Operating Costs.** If operating costs are excluded from the rental or lease agreement, the Contractor will be reimbursed for the cost of operating the equipment. The rate of reimbursement for operating costs will be based on the Rental Rate Blue Book for Construction Equipment. Operating costs only apply to hours of actual operation.
3. **Overhead Rates.** The Contractor will be reimbursed for overhead costs at a rate of 10 percent according to subsection 109.04 of the Standard Specifications.
4. **Negotiated Equipment Rental Rates.** Negotiated equipment rental rates may be used if they are less than those published in the Rental Rate Blue Book for Construction Equipment, including operating costs. Justification for negotiated rates must include the equipment number and rental rate from Form 580.
5. **Rental Rates for Small Tools.** Small tools are generally valued between \$500 and \$2,000. The rental rate for small tools will be \$2 per hour of use. Standby rates do not apply to small tools according to subsection 109.04 of the Standard Specifications.
6. **Reimbursement for Fast-Wear Expendable Parts.** If substantiated by a certified invoice, items such as saw blades, tooth-bits for saws, pavement breakers, and other similar equipment will be reimbursed at invoice cost plus 10 percent. Payment will be made based on the percentage of wear caused by the work. The 15 percent loading for materials specified in subsection 109.04(b) of the Standard Specifications does not apply to fast-wear expendable parts.

120.15.3.9 Payment Procedures for Force Account Work

Before payment is made for force account work, subsection 109.04 of the Standard Specifications requires the Contractor to submit an itemized bill. In lieu of the Contractor submitting an itemized bill, the Project Engineer may choose to calculate the cost of the force account work. Consider the following when processing payment for force account work:

1. **Review and Approval.** The Project Engineer must review all force account invoices based on certified payrolls and the approved copies of Form 10. Pay the invoice on the

General Provisions

estimate and submit the original document to the Finals Administrator. This should be performed on a monthly basis as the work progress. Do not backlog force account bills until finalization.

2. Certified Invoices. Certified invoices from the Contractor must support billings for the following items:
 - a. materials,
 - b. rented or leased equipment, and
 - c. specialty firms.
3. Certification Statement. Certified invoices must contain the following statement, which has been signed by the Contractor:

We certify, by photocopy of this invoice, that the quantity of material/rental or lease/specialty work, represented by this invoice was purchased and received for CDOT Project No. _____ and that the prices shown are actual costs.	
Contractor:	Date:

4. Certified Payrolls. The Contractor must furnish certified payrolls for the labor used on the force account work, even though certified payrolls may not be required by the Contract (e.g., State-funded projects). The bill and payrolls will be reviewed for accuracy by the Project Engineer. A statement "Payrolls were checked by (Project Engineer name)" will be noted on the face of the Force Account Billing.
5. Employee Pay Rates. Employee pay rates will not exceed the normal pay rate nor the prevailing wage for the area (e.g., the Contractor cannot double the normal pay rate for employees on force account).
6. Salaried Foremen. If a salaried Foreman is being used on force account work, the Contractor must furnish a payroll certifying the Foreman's pay rate and fringe benefits.
7. Superintendent Wages. Superintendent wages are included in the loading and should not be paid for separately, unless previously approved by the Project Engineer before the expense was incurred. This may be applicable where the only work on the project is the force account work added by change order.
8. Supplemental Payrolls and Billing Corrections. If certified payrolls do not agree with Form 10, the Contractor must submit a supplemental payroll or a new force account billing to correct the error. Minor errors may be corrected on billings and a copy returned to the Contractor, but under no circumstance should certified payrolls be returned for correction.
9. Loading. Loading will be applied as follows:

- a. Actual Wages. Actual wages and fringe benefits that are paid directly to the employee will be loaded 67 percent.
 - b. Material Costs. A loading of 15 percent will be applied to material costs, including applicable transportation costs.
 - c. Fast-Wear Expendable Parts. A loading of 10 percent will be applied to fast-wear expendable parts.
 - d. Administrative Loading. In accordance with subsection 109.04 of the Standard Specifications, administrative loading will be applied to the total force account work for subcontractors, specialty firms, utilities, and railroads.
10. Mathematical Checks. Calculations will be checked. Minor errors can be corrected by the Project Engineer and a copy returned to the Contractor.
11. Approval and Submittal. When the billing has been completely checked, it should be approved by the Project Engineer and submitted to the Finals Administrator. Submittal will include the following original documents as necessary:
- a. Form 10,
 - b. Form 580,
 - c. Contractor billings,
 - d. subcontractor billings,
 - e. certified invoices for materials,
 - f. statement of materials taken from stock,
 - g. certified invoices for specialty firms, and
 - h. certified invoices for equipment rentals or leases.
12. Alternative Documentation Method. Alternatively, the Project Engineer will calculate the cost of the force account work before approving payment. If this method is used, the Project Engineer will use the following data to calculate the cost of the force account work:
- a. Form 10,
 - b. Form 580,
 - c. certified payrolls, and
 - d. certified invoices.

Items #1, #10, and #11 are not applicable to this payment procedure. After calculation by the Project Engineer, all documentation will be included with the final documentation submitted to the Region Finals Administrator.

120.15.4 Stockpiled Material

Payment will be made for stockpiled material only after testing, receipt of all Certificates of Compliance, and acceptance by the Department (see Section 109.7). The Contractor must submit the following documentation, which the Project Engineer will retain in the project file:

1. Certified Invoice. A certified invoice for purchased material must contain the following statement, which must be signed by the Contractor:

We certify, by photocopy of this invoice, the quantity of material represented by this invoice was purchased and received for CDOT Project No. _____, and the prices shown are actual costs.	
Contractor:	Date:

2. Cost Analysis. A cost analysis must be provided by the Contractor in accordance with subsection 109.07 of the Standard Specifications. An example cost analysis follows:

We (Contractor) request payment for 1,740 linear feet of HP 10x57 Steel Piling at the invoice cost of \$8.97/linear foot. The following is a cost analysis showing sufficient funds remain to install the material:	
Invoice Cost:	\$8.97/linear foot
Labor to Install	\$3.58/linear foot
Equipment to Install	\$14.42/linear foot
Total Cost	\$26.97/linear foot
The total cost is less than the \$30.00/linear foot bid price, and the total amount requested for stockpile payment is \$15,607.80	
Contractor Superintendent:	Date:

The Project Engineer will review this analysis for reasonableness. If the analysis is considered reasonable, the Project Engineer will sign and date it. Otherwise, it will be returned to the Contractor for further information or revision.

3. Letter of Vested Interest. If the site is not on the project or state-owned property, a Letter of Vested Interest from the owner and/or lessee of the property will be required.

If the storage site is owned or leased by an entity (e.g., a city, county, transportation district), the Letter of Vested Interest will be signed by the entity employee who is responsible for that site. See Appendix B for an example.

120.15.5 Partial Payments

Partial payments to the Contractor are made once each month as the work progresses. Consider the following guidelines:

1. **Retainage/Securities.** The amount to be retained from partial payment, per specification, is automatically calculated. Subsection 109.06 of the Standard Specifications explains procedures to be used for reducing retainage or securities. The Contractor may provide securities in lieu of cash retainage to be withheld from payments. The Project Engineer will ask the Contractor if he intends to provide securities in lieu of retainage at the Preconstruction Conference. After the securities have been deposited, the pay estimate computer program automatically posts them to the estimate. Questions concerning procedures for depositing or posting securities should be directed to the Projects & Grants Accounting at dot_projectsandgrantsaccounting@state.co.us.
2. **Mobilization.** Appropriate payment is made automatically by the pay estimate computer program. No additional documentation need be maintained.
3. **Traffic Control Devices.** The number of devices actually used needs to be reported. The payment amount is automatically calculated by the pay estimate computer program in accordance with subsection 630.16 of the Standard Specifications.
4. **Price Reductions.** Price reductions should be added to the estimate as a negative dollar amount in the pay item section.
5. **Supplier Claims.** Supplier claims should not be included as an adjustment to retainage. A separate line item with a negative dollar amount should be used.
6. **Liquidated Damages.** Liquidated damages should be added to the estimate as a negative dollar amount in the construction engineering bid item section of the estimate.

SECTION 121 FINAL PROJECT RECORDS

121.1 GENERAL REQUIREMENTS AND RESPONSIBILITIES

Documentation requirements are discussed in Section 120. Section 121 discusses final project records and requirements for preparing and checking final plans and estimates. Although this Section presents commonly encountered situations, the Project Engineer should contact the Region Finals Administrator or Materials Final Documentation Coordinator for assistance when exceptions are encountered.

121.1.1 General Requirements

The following general requirements apply to project finalization:

1. Final Quantity Records. Acceptable documentation will be a record that supports the final quantity. All final measurements and quantities will be identified to distinguish them from interim measurements or quantities.
2. Signature Approvals. Hard copy documentation is not complete until it is signed or initialed and dated by the originator. The authorized SiteManager® Access Agreement fulfills this signature requirement for documentation in SiteManager®. Documentation Formats. Final pay quantity documentation may be submitted using any acceptable format. The Project Engineer will notify the Finals Administrator and Materials Final Documentation Coordinator which format is used to submit the finals documentation. The following are examples of acceptable formats:
 - a. Electronic records will be preserved with Smart Scanning and archived in ProjectWise (see <https://www.codot.gov/business/designsupport/cadd> for consultant access information and the CDOT ProjectWise Reference Manual for the Construction file structure)
 - b. Electronic records in SiteManager®
 - c. CDOT numbered forms, bound and indexed;
 - d. Contractor scale tickets, totaled and checked;
 - e. data processing output, checked and signed;
 - f. drawings and calculations, checked and signed; and
 - g. plan and cross-section sheets, checked and signed.

When electronic documentation is submitted, hard copy duplicates of this documentation need not be submitted but will be retained in the project file.

3. Review and Payment. The preparation and checking of final plans and estimates must allow the final payment authorization to be submitted to the Center for Accounting within 45 calendar days after receiving all Contractor submittals and resolving all Contractor claims and supplier liens (i.e., completion of all Contract requirements).
4. The intent of the Finals Checking Procedure is to ensure reasonable conformance to CDOT Policies and Procedures, and specification requirements; and to audit the accuracy of quantity measurements.

121.1.2 Responsibilities of the Project Engineer

As the representative of the Chief Engineer, the Project Engineer has the responsibility for proper documentation, including final documentation, on the project. The Project Engineer will ensure that CDOT documentation procedures are followed. All documents should be filed in ProjectWise. File naming and attribute assignments shall be applied to all documents.

The Project Engineer is responsible for ensuring that all quantities have been checked before the final estimate is paid.

The Project Engineer is responsible for ensuring that final documentation is completed in a timely manner. The Project Engineer will actively pursue completion of the final, even if the Contractor has not submitted all required documentation. If the Project Engineer completes the final documentation and the Contractor has not submitted the required documentation (e.g., Form 17, Buy America Certification Letter, Certificates of Compliance, certified payrolls), the final will be submitted to the Region for checking. See Appendix B for a sample Buy America Certification Letter.

The Project Engineer will complete and submit final documentation to the Finals Administrator within 45 calendar days of issuing the acceptance letter. The Project Engineer is responsible for all time from the date of the acceptance letter until he has submitted all documents under his control, i.e., all documentation for which the Contractor is not responsible.

121.1.3 Responsibilities of the Region Finals Administrator

The Region Finals Administrator is responsible for:

1. providing guidance in the Region to ensure uniformity in project documentation pursuant to the requirements of this manual;
2. auditing project documentation for conformance to CDOT specifications, policies and procedures, Federal, State, and other rules and regulations;
3. auditing calculations to ensure accurate and uniform application of specified methods of measurement and basis of payment;
4. auditing accuracy of posting quantities;
5. verifying all disputes/claims have been resolved and settlements posted to the final estimate;

6. verifying all subcontractor/supplier liens and/or lis pendens are resolved; and
7. authorizing final payment to the Contractor.

The Region Finals Administrator will begin the finals checking process as soon as practicable. Finals checking or submittal of the final will not be delayed while waiting for documentation.

The Region Finals Administrator will complete his review of the final documentation within 45 calendar days of receipt of the documentation from the Project Engineer. The Region Finals Administrator is responsible for all time from the time that the Project Engineer has submitted the project final as defined in Section 121.2.7 of this Manual, until the Finals Administrator completes the checking of those documents.

The Finals Administrator is responsible for accurately tracking and reporting these time durations to the Construction Engineering Services Branch via the Project Closure Report.

121.2 PROJECT FINAL PROCEDURES

121.2.1 Basis of Payment Documentation

The following presents the final documentation required by specified basis of payment (see Appendix B for sample forms):

1. Lump Sum. Document the beginning and end dates of work.
2. Each. Document the final quantity as counted in the field.
3. Linear Foot. Document the final field-measured length or plan quantity, whichever is specified in the Contract.
4. Ton (Measured by Weighing). Quantities for items such as HMA or aggregate base course should be documented as follows:
 - a. Scale Tickets. Include in the final documentation the daily envelopes containing scale tickets and tapes. Ensure that all manual entries and calculations are checked. Envelopes and scale tickets shall be labeled with the following information:
 - i. date and project number;
 - ii. material;
 - iii. location of spread (e.g., scale ticket, Form 282, spreadsheet);
 - iv. total; and
 - v. signature of person responsible for quantities and spread data.
 - b. Certifications. Attach one copy of scale and weigher certifications and vehicle identification sheets with the applicable pay item documentation that is

submitted to the Region. The vehicle identification sheets furnished by the Contractor shall contain the following information:

- i. Identification mark,
 - ii. vehicle length,
 - iii. tare weight,
 - iv. number of axles,
 - v. the distance between extreme axles, and
 - vi. information relative to determining legal weight, including the permit number and permitted weight of each vehicle for which the State has issued an overweight permit. Obtain new copies of this information whenever there is a change
5. Ton (Asphalt Cement). Include invoice or tank stabs, if used. Meter readings are acceptable.
 6. Area (e.g., Square Yard). Include Final measurements and calculations.
 7. Hour or Day. Document the total number of days and hours for each item.
 8. M-Gallon (e.g., water for landscaping). Quantity will be determined by measuring and calculating tank volume or by using meter readings.
 9. Gallon (e.g., prime and tack coats, pavement-marking paint). Use tank stab readings, meter readings, or truck weight data. Calculations for conversions and rate-verification calculations will be included.
 10. Pound (e.g., structural steel, reinforcing steel). Quantity will be based on plan quantity or recalculation of field changes or errors. Form 279 (see Appendix B) can be used to document quantities of reinforcing steel.
 11. Area (e.g., seeding, fertilizer, mulching). Ensure that tags were submitted. Document in the project records that tags were submitted. Retain the tags in the project records. Quantity will be based on plan quantity or recalculation of field changes or errors.
 12. Volume (e.g., cubic yard for earthwork). Quantity will be based on plan quantity or, if field changes are made or a plan error is found, one of the following:
 - a. recalculation based on field change or error;
 - b. computer output check, signed and dated;
 - c. final measured dimensions and calculations, checked and signed; or
 - d. field notes or plotted cross-sections and calculations, checked and signed.

Note that load count is not an acceptable method of documenting final pay quantities for earthwork.

13. Volume (e.g., cubic yard structure earthwork). Quantity will be based on plan quantity or, if field changes or a plan error applies, one of the following:

- a. recalculation based on field change or error;
- b. computer output - checked, signed, and dated;
- c. final measured dimensions and calculations, checked and signed;
- d. field notes or plotted cross-sections and calculations, checked and signed;
- e. design-aid factor and source identified with number and date; or
- f. pro-ration - plan versus final structure length.

14. Volume (e.g., cubic yard for structural concrete). Quantity will be based on plan quantity or recalculation based on change or error.

121.2.2 Documentation for Pay Items

Final quantities for pay items should be determined as soon as they are completed to ensure that final estimates can be completed promptly. Rounding and appropriate significant figures of final estimate quantities are discussed in Section 121.2.5. The following Sections discuss the documentation requirements for key pay items.

For the items, which will not be measured but shall be the quantities designated in the contract, i.e., plan quantity, spot-checking of plan quantities is a good practice to ensure accurate quantities. If field changes are ordered or discrepancies in the plans exist, the Project Engineer is required to measure and document.

The location of completed work will be documented on the source document.

For items, which are measured, the Project Engineer will follow the method of measurement and basis of payment for the item. Over-runs and under-runs will be documented on the source document.

121.2.2.1 Excavation and Embankment (Section 203)

Items paid by volume will not be remeasured but will be the quantities designated in the Contract. Exceptions will be made when field changes are ordered or when it is determined that there are discrepancies on the plans in an amount of at least plus or minus two percent. The Contractor will be immediately notified of any deviation in quantities. All accepted excavation and borrow will be measured in their original position.

121.2.2.2 Structural Excavation and Backfill (Section 206)

Structural excavation and backfill generally should be the quantities shown on the plans. Only major errors and changes, which significantly alter quantities, should be considered. Nominal changes in length, depth, and location do not require recalculation, and minor changes that will not significantly change the cost of installation should not be considered as a basis for alteration of pay quantity.

121.2.2.3 Bases and Pavements (Sections 300 and 400)

When payment is by the ton, an envelope containing the Contractor's scale tickets, daily tare weights, and one of the following methods is required: Two adding machine tapes each signed by a different individual, one hand-checked adding machine tape checked and signed by two different individuals, checked Form 282, or a checked printout from a computer spreadsheet must be made daily and submitted with the final estimate to the Region. Reasons for partial loads or voided tickets must be stated on the ticket. Scale certification, weigher certification, vehicle number and length list may be included in the envelopes or with the pay item documentation submitted to the Region. When the base material is measured by the cubic yard, documentation will include standard volume calculations.

121.2.2.4 Piling (Section 502)

Field notes will record piling heat number, cut-off location and lengths, number of splices, and final penetration in accordance with Section 502 of this Manual. Special attention will be given to the reuse of steel cut-offs to prevent double payment. Each pile cut-off will be marked so that if a cut-off is reused, its original location can be identified, and double payment can be prevented. Individual cut-offs will be measured to the nearest one-tenth of a foot. Final quantities will be tabulated to the nearest foot. Cut-offs will be paid under a separate line item at the rate shown in Section 502. As-Constructed Pile Tip elevations shall be documented in the As-Constructed Drawings.

121.2.2.5 Concrete Slope and Ditch Paving (Section 507)

Payment for concrete slope and ditch paving will be based on final field measurements and calculations. Calculations involving thicknesses of four-inch, eight-inch, etc., will be made using the fraction (1/3, 2/3, etc.).

121.2.2.6 Structural Steel (Section 509)

The weight of structural steel will not be remeasured or recalculated but will be the quantities shown on the plans. Exceptions will be for changes in design or for any error in excess of specified limits in the total weight shown on the plans.

121.2.2.7 Structural Concrete (Section 601)

Structural concrete will not be remeasured but will be the quantities shown on the plans, except when field changes are ordered, or it is determined there is an error in the plan quantity

in excess of the specified limits. If recalculation is required, final payment will be made on the calculated quantity. Calculations involving thickness of four-inch, eight-inch, etc., will be made using the fraction (1/3, 2/3, etc.).

121.2.2.8 Reinforcing Steel (Section 602)

Reinforcing steel in structures will not be remeasured or recalculated, but will be the quantities shown on the plans, except when field changes are ordered, or it is determined there is an error in plan quantity in excess of specified limits. If a recalculation is required, final payment will be made on the recalculated quantity.

121.2.2.9 Price Reductions (Section 105)

Price-reduction calculations should be submitted in accordance with the procedures discussed in Section 120.7.7.10. These reductions will be added as separate items to the estimate.

121.2.3 As-Constructed Plans

121.2.3.1 Availability

Original plans and cross-sections are generally available from the Resident Engineer. If unavailable, the Region will need to obtain an unmarked set of plans from ProjectWise®.

121.2.3.2 Incorporation of Changes

As required by CDOT Procedural Directive 508.1 - Professional Engineer's Stamp, changes in the scope of work, intent of Contract, geometric design, structural plans, typical sections, standard plans, specifications, and corrections of design errors must be incorporated into the As-Constructed Plans. The designer may have generated project plan sheets either manually or electronically. If the plan sheets have been prepared electronically, as-constructed revisions should be completed using electronic software. See the CADD Manual for electronic completion of As-Constructed Plans using MicroStation® or Redline software. If other software, such as Adobe, is used to complete As-Constructed Plans, the work shall closely approximate what is described in the CADD Manual for electronic software.

Each set of As-Constructed Plans will be prepared under the supervision of the Project Engineer who supervised construction. The Project Engineer should prepare As-Constructed revisions as construction progresses but must not revise the original electronic software file. A backup copy of the original file will be created before revisions are made. Do not delete data from original plans; rather, cross out information that is no longer needed or accurate. The following Sections discuss the procedures to revise As-Constructed Plans. The As-Constructed plans shall include any changes and be Sealed by the Engineer responsible for those changes. As CDOT transitions from paper to electronic records, As-Constructed plans will be developed electronically or scanned in an Adobe PDF/ A-1 b ISO Compliant format and archived in ProjectWise Explorer.

121.2.3.2.1 Electronic and Manual Procedures

The following applies to both electronic and manual procedures:

1. **As-Constructed Box.** In the as-constructed box on each plan sheet, place the project acceptance date in either the “Revised,” “No Revisions,” or “Voided by Construction” space.
2. **Adding Sheets.** Add sheets by adding a suffix (e.g., 3A, 3B).
3. **Replaced Sheets.** Replace sheets by adding “X” to the sheet number (e.g., 3X).
4. **Title Sheet.** The title sheet should present complete information, as follows:
 - a. Contractor;
 - b. Resident Engineer;
 - c. Project Engineer;
 - d. start date;
 - e. project acceptance date;
 - f. comments;
 - g. project number;
 - h. five-digit project code (subaccount), if not already shown;
 - i. beginning and ending location; and
 - j. change order number if there is a project extension.
5. **Index.** Revise the index of plan sheets as required. List the sheets that were “Added,” “Substituted,” or “Voided by Construction.” Do not add sheet numbers for cross-sections to the index.
6. **Typical Section Sheets.** Show any changes to base course or surfacing thickness with the appropriate change order number. Add, revise, or delete typical sections, and list the appropriate change order numbers.
7. **Summary Sheets.** Use the following procedures to prepare summary sheets for As-Constructed Plans
 - a. Complete a “Summary of Final Quantities” with change order numbers beside affected items.
 - b. It is unnecessary to indicate planned or final force account dollar amounts.
 - c. Any force account items added by change order should be shown.
 - d. Any items that have been deleted must reference the change order or the CDOT Form 105 that authorized the deletion.
8. **Structures.** Use the following procedures to prepare structural sheets:

- a. Show actual tip elevation of piling for each pier, wall, or abutment. Columns for actual tip elevations are often included in structural piling layout drawing.
 - b. Show any structure changes for both minor and major structures.
 - c. Show type, manufacturer, manufacturer's project number, and shop drawing number of bridge expansion and bearing devices installed.
 - d. Show elevation and placement of brass cap benchmarks, when used. The elevation should be project specific and marked on the plans. All temporary benchmarks on the plans will be lined out.
 - e. Vertical and lateral clearances should be indicated.
9. Plan and Profile: Use the following procedures to prepare plan and profile sheets:
- a. Show the final location of new utility placements, unknown utility discoveries, relocations, and changes. Abandoned utilities should be shown and noted.
 - b. Show all geometric revisions to alignment, super elevation, and grade. Include the change order number as appropriate.
 - c. Show significant changes in revised slope catches specifically ordered in the field. Include change order numbers as appropriate.
 - d. Show final locations of minor structures.
 - e. As-constructed information must be completed on the item tabulations for significant items such as structures. However, incidental tabs for items such as landscaping, delineation, etc. may be crossed out instead.
 - f. Show locations of any petroleum-contaminated soils incorporated into earthwork for disposal, as approved by the Region Planning and Environmental Manager.
 - g. Show locations of discovered underground features, such as foundations or pipes, which are left in place.
 - h. Show detailed information on the location of all buried material within the CDOT right of way or project limits.
 - i. Detail any new or deleted accesses.
10. Tabulation of Quantities. Individual tabulations of separate pay items may or may not be edited, as determined by the Project Engineer, to reflect the actual as constructed quantities. It is important that all individual tabulations match the final quantities, if not crossed out. If tabulation information is not corrected, the tabulation shall be crossed out and a reference made to "See Summary of Approximate Quantities Sheet No. X".
11. Altering Verbiage. Notes may be altered to reflect the as-constructed condition.

12. Landscape Plan Sheets will not be updated except that the tabulations may be updated as determined by the Project Engineer.

121.2.3.2.2 Electronic Procedures

See the CADD Manual for electronic completion of As-Constructed Plans using MicroStation® or Redline software. If other software, such as Adobe, is used to complete As-Constructed Plans, the work shall closely approximate what is described in the CADD Manual. Revisions will not be made to original electronic software files. A backup copy of the original file will be used to enter the as-constructed revisions. Procedures for the electronic preparation of As-Constructed Plans are as follows:

1. Leave original data in the electronic file intact.
2. Do not delete any layers in the electronic file.
3. All text revisions are to be completed using the AsConst font in MicroStation® or Redline. If other software is used to complete As-Constructed Plans, a freehand print font available through the electronic software may be used.
4. The original design information is contained on the frozen layers of the electronic file copy and in the record set as outlined in CDOT Procedural Directive 508.1.
5. Additional levels will be created in the electronic software file to enter as-constructed information as described in the CADD Manual. These levels will be labeled as described in the CADD Manual. Do not show features on the plot of the As-Constructed Plans that no longer exist (e.g., roadway alignments, approaches, fences, utilities, and grades).
6. The original sheet will be removed and replaced by the hard copy plot showing as-constructed information in the As-Constructed Plans. Hard copy plots are to be printed using the “black and white” option.
7. When as-constructed revisions are completed using electronic software, sheets marked “Voided by Construction” will occur only if the work covered by that sheet was not performed. For example, if the project termini were shortened by change order, the affected plan/profile sheets would be marked “Voided by Construction.”
8. In addition to the hard copy distribution, electronic copies of As-Constructed Plans developed using electronic software will be retained by the Resident Engineer.

121.2.3.2.3 Manual Procedures

Use the following procedures to manually prepare As-Constructed Plans:

1. Complete all revisions in red using a non-smearing writing implement.
2. Line out plan data being corrected.
3. Indicate removals, by crossing out, when construction operations have obliterated features that were originally shown on the plans as existing.

4. When as-constructed revisions are completed manually, instances of sheets marked “Voided by Construction” will occur only if the work covered by that sheet was not performed. For example, if the project termini were shortened by change order, the affected plan/profile sheets would be marked “Voided by Construction.”

121.2.4 Final Estimates

Quantities on the final estimates must agree with the “Summary of Final Quantities” on the As-Constructed Plans. The following procedures will be performed on force account billings that have not been received by the Project Engineer within 90 days after final settlement has been advertised and final checking has been completed:

1. Project Engineer. Estimate the value of the outstanding force account billings including the value of all manpower, equipment, materials, and railroad flagging. Submit the estimate to the Region Finals Administrator.
2. Region Finals Administrator. Create a line item for each force account-billing item and add the line item to the final estimate. Process Form 950 - Project Closure, according to Section 121.3.5 and notify Projects & Grants Accounting by means of Form 96 - Contractor Acceptance of Final Estimate to escrow the amount of the outstanding force account billings.

121.2.5 Rounding of Final Estimate Quantities

If a specification indicates that the method of measurement for a particular item will be plan quantity, all interim estimate quantities will be rounded to the nearest whole unit. Otherwise, the final quantity should be rounded according to this Section. Round the final quantity to the proper decimal as detailed in Figure 100E.

As the unit price value of any item increases, a corresponding increase in number of figures to the right of the decimal will be used. If the last digit of a number to be rounded is 4 or less, round down, if 5 or greater, round up. For example, 2.74 will be rounded to 2.7 and 2.75 will be rounded to 2.8.

121.2.6 Final Project Records

As CDOT transitions from paper to electronic records, Final Project Records will be developed electronically or scanned in an Adobe PDF/ A-1 b ISO compliant format and archived in ProjectWise Explorer. The following final project records, books, and documents will be submitted to the Region Finals Administrator and in some cases to the Materials Final Documentation Coordinator. Electronic format is always preferred:

1. documentation supporting pay quantities,
2. civil rights and labor compliance documentation,
3. survey documentation,
4. as-constructed plans,

5. materials documentation, and
6. any additional documentation required by CDOT Specifications, FHWA or other state or local regulations.

A Final Notebook or Packet will be submitted by the Project Engineer to the Region Finals Administrator. The Project Final Submittal Checklist (Appendix B) will be used as the table of contents to assemble a tabbed notebook for the project documentation.

A separate Final Materials Notebook or Packet will be submitted to the Region Finals Administrator for the project materials documentation. The Final Materials Submittal Checklist (Appendix B) will be used as the table of contents to assemble a tabbed notebook for the project materials documentation.

The “List of Items Retained by the Region” letter will show the distribution of these books, records, and documents. The residency will retain all supporting documentation for stockpiled materials in the project files.

Rounding Criteria for Pay Items	
Pay Unit	Rounding Criteria
Acre	0.X
Cubic Yard (concrete)	0.X
Cubic Yard	X.
Day	X.
Each	X.
Gallon	X.
Hour	X.
Linear Foot	X.
Lump Sum (%)	X.
M-Board Feet	0.XXX
M-Gallon	X.
Mile	0.XX
Pound	X.
Square Feet	X.
Square Yard	X.
Ton	0.XX
Yard-Mile	X.
<u>Legend</u> X. Round to the nearest whole unit. 0.X Round to the nearest tenth. 0.XX Round to the nearest hundredth. 0.XXX Round to the nearest thousandth.	

Figure 100 - 19

121.2.7 Contractor Reports

The following reports and forms shall be submitted by the Contractor to the Project Engineer, who will forward them to the Region Finals Administrator:

1. **Contract Payroll Data.** In accordance with FHWA Form 1273 - Required Contract Provisions Federal-Aid Construction Contracts, payroll data, including all appropriate CDOT forms, are required on all Federal-Aid projects exceeding \$2,000; however, projects on roadways classified as local roads or rural minor collectors are exempt. Contact the Resident Engineer to determine roadway classification.
2. **Buy America Certification.** Buy America Certification is required for steel and iron products.

The Project Engineer will encourage the timely submittal of all required reports as reduction in retainage or final payment cannot be made until all documentation has been received. Any documentation that has not been received at the time of project acceptance will be itemized in the Project Acceptance Letter.

121.3 ADVERTISEMENT FOR FINAL SETTLEMENT

The Region Finals Administrator, by memorandum or electronic mail, will request the Construction Engineering Services Branch to advertise each project for final settlement immediately after the project has been accepted. The Region Finals Administrator will send a copy of the memorandum or electronic mail to the Right-of-Way Program of the Project Development Services Branch, which will allow the Right-of-Way Program to clear any temporary easements.

121.3.1 Region Records

The Region Finals Administrator will maintain, at a minimum, the following records or data on each project:

1. **Number of Elapsed Days.** The number of elapsed days between project acceptance and final Contractor payment for each project will be calculated as shown below and reported on Form 325 - Final Estimate Data. The entry will represent the number of days that are the responsibility of the following parties:
 - a. **Field/CDOT Residency.** Time will accumulate in this category beginning at Final Acceptance and continuing until all required documentation under the control of the Project Engineer has been submitted to the Finals Administrator. Final documentation submittal by the Project Engineer will not be delayed by outstanding disputes or claims. Final checking by the Finals Administrator on all submitted documentation will be done in accordance with established procedures except preparation of the final estimate and submission of CDOT Form 96. Any necessary corrections by the Finals Administrator will be done prior to and independent of any dispute or claim resolution. When disputes or claims are resolved, necessary changes will be made and the final estimate and CDOT Form 96 will be submitted to the Contractor.

For example, a project is accepted on January 15, and the Project Engineer submits all documentation except for that which is required from the Contractor on February 15. The time that the Residency is responsible for will commence on January 15 and accumulate until February 15.

The Project Engineer is responsible for ensuring that the project final documentation is completed in a timely manner. The Project Engineer will actively pursue completion of the final even if the Contractor has not submitted all required documentation. If the Project Engineer completes the final project documentation and the Contractor has not submitted the required documentation (e.g., Form 17, Buy America Certification Letter, Certificates of Compliance, certified payrolls), the final will be submitted to the Region for checking.

- b. Region Finals Administrator. Time will accumulate in this category beginning when the Project Engineer has submitted all documentation under the control of the Project Engineer. For example, the Region Finals Administrator receives the final documentation package from the field on March 27, and completes the Region review on April 7. The Contractor submits missing forms on April 14 and the Region sends out the Form 96 on April 16. The Form 96 is again received by the Region on April 28, and final payment is made on April 30. The Finals Administrator is responsible for the time from March 27 to April 7, April 14 to April 16, and from April 28 to April 30.
- c. Contractor. The Contractor shall be responsible for other periods of time when the only item holding up the review is the lack of documentation from the Contractor. This procedure will ensure final payment is made as soon as possible.

When the Region is experiencing difficulty obtaining the required documentation from the Contractor the following escalation procedure will be used:

- a. The Project Engineer or Resident Engineer will notify the Contractor in writing regarding the need for missing documentation.
 - b. If the Contractor does not respond within 30 days, the Resident Engineer will escalate the issue to the appropriate Region Program Engineer.
2. Date Review Begins. Document the date the final documentation review was started.
 3. Name of Reviewer. Document the name of the final documentation reviewer.
 4. Checking Percentage. Document the number of items checked and the total number of items on the final estimate. The method of computing percentage checked will be the dollar amount of the items checked divided by the final Contract amount.
 5. Date Review Ends. Document the date the final documentation review was completed.

121.3.2 Region Review Procedures

The Region Finals Administrator will review the final project documentation to ensure that the field personnel responsible for creating and checking the project documentation have reasonably followed CDOT specifications, policies, and procedures.

A Final Documentation Risk Analysis will be used to determine the extent of the documentation review required. The Region Finals Administrator may complete the Final Documentation Risk Assessment Form, illustrated in Figure 100F, for each project before commencing review of the final project documentation. If four or more factors in this analysis are considered high risk, the finals documentation for this project will be considered high risk, and additional checking will be instituted.

FINAL DOCUMENTATION RISK ASSESSMENT		
Project Number:		
Project Code Number:		
Description:		
Factor	Risk	
	High	Low
Final Cost/Bid Cost (More than 110% = High Risk).		
Project History (Construction problems?).		
Experience of Project Staff.		
Project Size (Number of pay items/project dollars).		
Complexity of Project (Phases, multiple construction types).		
Number and size of Change Orders.		
Consultant/CDOT Team Performance.		
Organization and Detail of Documentation.		
Percentage of Force Account Work (More than 10% = High Risk).		
Lump Sum Pay Items in excess of 10% of the project		
Comments:		
Region Final Administrator:		Date:

Figure 100 - 20

Final documentation will be reviewed as follows:

1. Review Identification. The Region Finals Administrator will identify information each has reviewed by using a red check mark.
2. Periodic Field Reviews. The Region Finals Administrator may conduct periodic documentation field reviews of active projects.
3. Extensive Reviews. The Region Finals Administrator will make a complete final documentation review on a minimum of one project in every 20 (i.e., five percent). At least one-half of the projects on which a complete review is performed will have a cost exceeding \$1 million.
4. Major Pay Item Reviews. The following procedures will be used to review final documentation on all projects not completely reviewed in Item #3. A major pay item is defined as any pay item with a final cost that exceeds ten percent of the final Contract amount.
 - a. Two pay items will be completely reviewed per each \$1 million of final Contract amount (e.g., three pay items would be completely reviewed on a project with a final Contract amount of \$1.5 million). Major or high-risk pay items will be checked first.
 - b. If any significant documentation deficiencies are found, one additional pay items per \$1 million of final Contract amount will be reviewed. The Project Engineer will meet with the Region Finals Administrator to review the documentation and correct all deficiencies.
5. Other Pay Item Reviews. The Region Finals Administrator may review other pay items if the risk associated with measurement and payment of a pay item is considered significant enough to require a check.
6. Force Account Billings. Force account billings will be reviewed for proper procedure (see Section 120.15.3).
7. Scales and Water Tickets. The Project Engineer will review scale and water tickets. The Region Finals Administrator will verify that established procedures have been followed. No further checks will be required unless the procedural review reveals deficiencies.
8. Signature Authority. The Region Finals Administrator will sign the estimate sheets and voucher for all final estimates. The signature line on the final estimate voucher will state the following: "I hereby approve payment." The signature will constitute full authority for payment to be made on the final estimate.

121.3.3 Distribution by Region Finals Administrator

After the Region Finals Administrator has received, reviewed, and checked all the required and applicable documentation, one copy each of the forms will be distributed by the Region Finals Administrator as illustrated in Figure 100 - 17. As CDOT transitions from paper to electronic records, Final Project Records will be developed electronically or scanned in an Adobe PDF/ A-1 b ISO Compliant format and archived in ProjectWise Explorer.

General Provisions

Document	Distribution
Form 325	Construction Engineering Services Branch ProjectWise Explorer in Adobe PDF/ A-1 b ISO Compliant format Projects & Grants Accounting Resident Engineer
Form 17	Construction Engineering Services Branch (Original) EEO Business Programs
EEO COC	ProjectWise Explorer in Adobe PDF/ A-1 b ISO Compliant format Resident Engineer
Form 1212	FHWA ProjectWise Explorer in Adobe PDF/ A-1 b ISO Compliant format Projects and Grants Section (Center for Accounting)
Form 96 (signed by Contractor)	Projects and Grants Section (Center for Accounting) (Original) Region Business Office Resident Engineer
Final Estimate	Projects and Grants Section (Center for Accounting) (Original w/original voucher) FHWA (Oversight projects only) Materials Engineer Resident Engineer
Form 250	ProjectWise Explorer in Adobe PDF/ A-1 b ISO Compliant format Region Materials Engineer Resident Engineer FHWA (Oversight projects only)
Buy America	ProjectWise Explorer in Adobe PDF/ A-1 b ISO Compliant format FHWA (Oversight projects only) Region Materials Engineer Resident Engineer
Form 473	ProjectWise Explorer in Adobe PDF/ A-1 b ISO Compliant format FHWA (Oversight projects only) Materials and Geotechnical Services Branch Resident Engineer
Form 262/263	FHWA (Final time count only on Oversight projects)

Document	Distribution
List of Items Retained by Region	ProjectWise Explorer in Adobe PDF/ A-1 b ISO Compliant format Resident Engineer
As-Constructed Plans	ProjectWise Explorer in Adobe PDF/ A-1 b ISO Compliant format 1 e-file copy to Staff Right-of-Way # of copies needed + original to Region

Figure 100 - 21

121.3.4 Construction Phase Closure

The CDOT Controller, in conjunction with the Federal Highway Administration, has established procedures to expedite the closure of projects following project acceptance. These procedures require the closure of the construction phase of a project within six months after the project acceptance date. At the end of this six-month period, charges against the project will not be allowed unless an extension notification or request has been submitted in accordance with the requirements discussed in this Section.

Extensions of the construction phase of the project may be needed for settlement of Contract disputes, claims against the Department, or for completion of pending investigations. In the event that a lengthy extension period is anticipated for any reason, procedures are available to escrow project funds to allow for project closure until a determination has been reached on unresolved issues. The procedures for escrowing project funds are discussed in Section 121.3.5 and should be used, as practical, to expedite closure of the construction phase of a project. Consider the following:

1. Content of Correspondence. All correspondence regarding notification or requests for construction phase extensions will include the following information:
 - a. Project Information. Include the project number, project code (subaccount), and location.
 - b. Subject Line. In the subject line, include either “Notification” or “Request” for extension to distinguish between the two possibilities.
 - c. Acceptance Date. Include the project acceptance date and extension period (in months) beyond the acceptance date.
 - d. Justification. Include justification for the extension, including sufficient detail of the circumstances, such as:
 - i. Contractor submittals not received and discussion verifying that the Contractor has been informed of any deficiencies;
 - ii. Contract dispute issues and status of the issues;

- iii. claims against the Department and status of the claims; and
 - iv. status of project final documentation review and discussion of pertinent investigations
- 2. Requests for Extensions Less Than 12 Months. The following procedures are applicable to an extension request of an additional six months up to 12 months after project acceptance:
 - a. If resolution of the pending issues is anticipated between six and 12 months after the project acceptance date, the Project Engineer will request the Region Business Manager to notify the Projects and Grants Section in writing of the need for a six-month extension of the phase closure date.
 - b. The notification will include the information presented in Items 1.a through 1.d above.
 - c. A copy of this notification will be forwarded to the Construction Engineering Services Branch.
 - d. Requests for extensions will not be granted if the pending issues have no financial impact on the project or if outstanding project costs can be escrowed.
- 3. Requests for Extensions Greater Than 12 Months. The following procedures are applicable to an extension request for more than 12 months after project acceptance:
 - a. If the Region determines the phase should remain open longer than 12 months after project acceptance, the Region Business Manager will send a request for the additional extension with appropriate justification to the Office of Financial Management and Budget with copies to Projects & Grants Accounting and the Construction Engineering Services Branch.
 - b. The request will explain why project charges cannot be placed in escrow or borne by a like-funded project.
 - c. Projects & Grants Accounting will record the additional phase extension upon approval.
 - d. The Construction Engineering Services Branch will monitor and track the status of all projects that have been extended beyond the allotted six months after project acceptance.
 - e. The Region is to report the status of construction phase extensions in the remarks section of Form 517 - Status of Construction Project Finals with a brief explanation of the reason for construction phase extensions and the anticipated extension period, in months, after project acceptance.

121.3.5 Escrow of Project Funds

The Department's project closure agreements with the FHWA require that the construction phase of projects be closed six months after CDOT accepts the project from the Contractor.

The procedures discussed in this Section will be used on projects with unresolved labor claims or subcontractor/supplier liens or when the Contractor fails to submit the required forms. Note that this process cannot be used when one of the following applies:

1. The Contractor has filed a claim in accordance with subsection 105.23 of the Standard Special Provision, Revision of Section 105 - Disputes and Claims for Contract Adjustments [projects controlled by the 2005 Spec Book].
2. The Contractor has filed a claim in accordance with subsection 105.24 of the Standard Specifications [projects controlled by the 2011 Spec Book].
3. The amount of any payment is in dispute.

When the project construction phase is complete except that the final estimate cannot be processed because of unresolved labor complaints or supplier liens or the Contractor has not submitted the required forms, the Region Finals Administrator will notify the Projects Accounting and Reporting Section of the Division of Accounting and Finance at dot_projectsandgrantsaccounting@state.co.us to initiate the escrow of project funds. The following actions will be taken:

1. Labor Issues. The following procedures will be used when the issue relates to labor complaints or other labor pay issues:
 - a. Projects & Grants Accounting will charge the project for the amount of the labor complaint and escrow the funds.
 - b. Upon notification, the Region Finals Administrator will run the final pay estimate, close the project, and initiate or request initiation of Form 950.
 - c. When the final estimate is run, the amount of the labor complaint previously withheld from the Contractor will be zeroed out in SiteManager® and the term “Escrowed” entered in the supplemental item description field in the Items Window in SiteManager®.
 - d. The Construction Engineering Services Branch will track the labor complaint and notify both the Region Finals Administrator and Projects & Grants Accounting when the complaint has been resolved.
 - e. Projects & Grants Accounting will prepare a payment voucher in accordance with the final resolution of the labor claim.
2. Subcontractor or Supplier Liens. The following procedures will be used when the issue relates to subcontractor or supplier liens:
 - a. The Region Finals Administrator will run the final estimate, close the project, and initiate or request initiation of Form 950.
 - b. When the final estimate is run, the amount of the lien previously withheld from the Contractor will be zeroed out in SiteManager® and “Escrowed” entered in the supplemental item description field in the Items Window in SiteManager®.

- c. Simultaneously, the Finals Administrator will submit to Projects & Grants Accounting a request to escrow the funds. This written request will include:
 - i. project number,
 - ii. project code number (PCN),
 - iii. Location,
 - iv. reason for escrow,
 - v. dollar amount escrowed,
 - vi. vendor number (from contractor payment voucher),
 - vii. contractor name, and
 - viii. the contractor address.
 - d. When the final pay estimate is processed for payment, Projects & Grants Accounting will establish an escrow for the same amount as the lien.
 - e. When Projects & Grants Accounting receives a release of escrowed liens or other resolution of the escrowed lien, payment will be made to the appropriate party from the escrow account. The Projects Accounting and Reporting Section will notify the Region Finals Administrator of either of these actions.
 3. Contractor Failure to Submit Required Forms. The following procedures will be used if the Contractor fails to submit the required forms, except when final quantities and additional payment may be affected:
 - a. The Region Finals Administrator will verify that the Contractor has been notified of forms not received (i.e., by means of the project acceptance letter and/or other correspondence) and will run the final estimate, close the project, and initiate or request initiation of Form 950.
 - b. Simultaneously, the Finals Administrator will submit to Projects & Grants Accounting a request to escrow the funds. This written request will include:
 - i. project number,
 - ii. project code number (PCN),
 - iii. location,
 - iv. reason for escrow,
 - v. dollar amount escrowed,
 - vi. vendor number (from contractor payment voucher),

- vii. contractor name, and
 - viii. the contractor address.
- c. Upon written notification by the Region Finals Administrator, Projects & Grants Accounting will prepare a journal voucher for the final payment and establish an escrow account.
 - d. When the Contractor submits the required forms, the Region Finals Administrator will notify Projects & Grants Accounting to release the escrowed final pay estimate amount to the Contractor.
 - e. If any of the overdue forms relate to payment issues that depend on paperwork submittal, the Project Engineer will review the forms upon receipt for correctness and forward them to the Region Finals Administrator. The Region Finals Administrator will revise Form 96 and make distribution. Projects & Grants Accounting will release the appropriate amount to the Contractor.

Projects & Grants Accounting will provide a quarterly status report of escrowed final pay estimate amounts to the Region Finals Administrator and the Area Engineers in the Construction Engineering Services Branch.

Note that Form 96 will identify and itemize dollar values that have been escrowed.

SECTION 122 LOCAL AGENCY PROJECT ADMINISTRATION

122.1 ADMINISTRATION OF FEDERAL-AID LOCAL AGENCY PROJECTS

The CDOT Local Agency Manual covers all topics in more detail. Federal-Aid funds are available to Local Agencies for the construction of roads, streets, structures, and other improvements, including enhancement projects. The FHWA requires the Department to certify that such projects are administered in accordance with Federal regulations.

122.2 QUALITY ASSURANCE - CDOT FEDERAL-OVERSIGHT PROGRAM

Regardless of the contract administrative procedures used, a CDOT/FHWA Quality Assurance Review will be performed on random projects in accordance with the CDOT/FHWA Stewardship Agreement (see Section 101.105).

122.3 CONTRACT ADMINISTRATION

The Local Agency Contract Administration Checklist will define the contract administration responsibilities of the parties involved in each Local Agency project, including enhancement projects. The types of contract administration procedures used for these projects are discussed in the following Sections.

122.3.1 Administration by the Department

When administered by the Department, CDOT will advertise, bid, award, and administer the project exactly like any other CDOT construction project. Consider the following:

1. **Region.** The Region will ensure that the project is administered in the same manner as other Federal-Aid projects.
2. **Resident Engineer/Project Engineer.** The Resident Engineer will be in responsible charge of all facets of contract administration and may delegate this responsibility to a Project Engineer.
3. **Change Orders.** The following statement, included in the body of the change order, must be signed by a qualified representative of the Local Agency or private owner for all change orders that involve the expenditure of Local Agency or private owner funds before the work covered by the change order commences:

Should Federal funds not be available to cover these additional costs, or the FHWA decide not to participate in these costs, the Local Agency or private owner agrees to provide the required funds.

The _____
(Name of Local Agency or Private Owner)

Approves this Change Order No. _____ by signing below.

Signature Title Date

Figure 100 - 22

122.3.2 Administration by the Local Agency

CDOT and the Local Agency will execute a project specific agreement that authorizes the Local Agency to assume responsibility for part or all of the contract administration on a specific construction project. The agreement will be completed and signed before the project is advertised.

The agreement will include a Local Agency Contract Administration Checklist. The checklist will indicate whether the Region or the Local Agency has assumed responsibility to perform each specific contract administration task on the project. When the Local Agency has assumed responsibility for any task on a project, the Local Agency will fulfill all requirements associated with that task as referenced in this Manual, including those usually designated to be completed by the Region Program Engineer, Resident Engineer, and Project Engineer.

122.4 REGION RESPONSIBILITIES FOR OVERSIGHT

Regardless of which party advertises, bids, and awards the project, the Resident Engineer, or Project Engineer as assigned, should review the agreement between the Local Agency and the Department to ensure that the following items are addressed:

1. Appointment of Project Engineer. The Local Agency will appoint a qualified Professional Engineer, licensed in the State of Colorado, as the Project Engineer. The Project Engineer may be an employee of the Local Agency or a consultant.
2. Assignment of Responsibility. The following statement will be included in the agreement to protect the CDOT Engineer's Professional Engineering License:

Notwithstanding CRS 12-25-103, the Project Engineer appointed by the Local Agency shall be in responsible charge of the construction supervision for the duties specified in the approved agreement.

3. Administration. The Project Engineer will administer the project in accordance with the approved agreement, Contract requirements, and CDOT policies and procedures. The

agreement should address the project administration tasks that the Local Agency/consultant will perform, such as:

- a. project inspection and testing;
- b. approval of material sources;
- c. record keeping (e.g., testing, inspection, pay documentation);
- d. preparation and approval of pay estimates;
- e. monitoring of project financial status; and
- f. processing of Contractor claims.

The Region will be responsible for assuring that all contract administration tasks not assigned to the Local Agency are performed by CDOT.

122.5 QUALITY CONTROLPROCESS CONTROL - CDOT FEDERAL- OVERSIGHT PROGRAM

The Resident Engineer will be responsible for approving change orders and determining whether the funding for change orders will be participating or non-participating. Before approving the change order, the Resident Engineer will perform the following:

1. Compliance Review. Review the change order and letter of explanation to ensure compliance with CDOT policies and procedures contained in this Manual.
2. Budget Review. Review the financial status of the project to ensure that the projected completion cost does not exceed the allotted budget. If the projected completion cost exceeds the allotted budget, the Resident Engineer will consult with the Region to determine if Federal-Aid funds are available and can be added to the project. Consider the following:
 - a. If additional Federal-Aid funds are available and can be added to the project, the Region will complete the required budget actions.
 - b. If additional Federal-Aid funds are not available, the Local Agency will provide the additional funds.

122.6 PROJECT REVIEWS

The Region will designate a Resident Engineer or Project Engineer to perform random project reviews and provide advice to the Project Engineer of the Local Agency.

The reviews by the Resident Engineer or Project Engineer will be sufficiently detailed to ensure that the Project Engineer of the Local Agency is administering the project in accordance with the terms of the Contract and the approved agreement. All CDOT reviews will be documented in the project diary, on the monthly pay estimate, or in the Field Review Form.

The Resident Engineer or Project Engineer will communicate only with the Project Engineer of the Local Agency, or his duly authorized assistant, and, except in an emergency, will issue no instructions to the Contractor or its Foremen.

122.7 FINAL PROJECT INSPECTION

As a quality control activity, the Resident Engineer will perform the final project inspection. See Section 109.9 for additional information on final project inspection and Form 1212 LA - Final Acceptance Report For Local Agency Projects. Notify Staff Bridge for assistance and coordination on projects with structures.

SECTION 123 COMBINED BRIDGE ENTERPRISE AND CDOT FUNDED PROJECTS

123.1 BACKGROUND

The Bridge Enterprise (BE) and CDOT are two separate entities with two separate funding sources. The BE is funded from an increase in registration fees for vehicles and is a result of legislation passed in Colorado in 2009. CDOT is funded from federal and state highway user taxes on gasoline.

CDOT projects can be set up in AASHTOWare® to accept several different funding sources. The funding sources are identified in AASHTOWare® and assigned a priority which defines the order in which each source of funding is spent. There are fundamentally four reasons why BE and CDOT funds cannot be comingled into one project this way.

1. TABOR Legislation - TABOR legislation prohibits one state governmental entity from giving money to another state governmental entity.
2. AASHTOWare® Voucher System - The AASHTOWare® system is set up to pay a contractor for work from a single owner, or CDOT, and is not capable of paying a contractor from two different owners. The AASHTOWare® Shazam/SAP interface that assigns a payment voucher from CDOT to the contractor would have to be modified to accommodate two owners.
3. Construction Engineering (CE) - CDOT has a CE pool from which indirect costs such as vehicles, buildings, Staff Services, etc. are funded. The BE will be billed directly for these types of charges. Because BE projects are not subject to the CE rate the CE work will have to be separated into two projects.
4. SAP - Numerous forms within SAP would require modification to accept a combination project (i.e., Form 65).

Region personnel must ensure that the work designed and performed is funded from the appropriate source. BE work must be accounted for and paid for separately from other work on the project and to do this the project should be entered into AASHTOWare® as a combination project (combo-project) before the project is advertised. Multiple Projects combined under one Contract/Proposal in the AASHTOWare® Project modules are a combo project. This Combo project approach allows for associating several projects under one Contract, with one Prime project, and one Proposal, for more efficient management both in our software system and in the field. Each project must begin as a separate project with a unique five-digit project code and associated funding in SAP. For further information and assistance with the combo-project business process, please contact the Alternative Delivery Branch or the Staff Bridge Branch. For assistance with AASHTOWare Project (Transport) system support contact the Data Program & Project Analysis group at systemsupport@cdot.mojohelpdesk.com.

123.2 GUIDANCE

1. Administer the project like any other typical project. However, as issues arise the PE and RE must keep BE funds separate from CDOT funds, or funds from any other source. Differences between the BE work and the other work should be clearly identified in the plans.
2. There could be split plan force account items in the BE category and the other work category. Be sure to post work items in the proper category in the Daily Work Report. Inspectors need to post to the correct item/category (i.e., MCR, OJT, Incentive/Disincentive, etc.) Refer to the category definitions above for additional information.
3. There will be a planned force account dollar value for Minor Contract Revisions (MCR) in the BE work category as well as the other work category.
4. Change Orders, if required, must be added to the appropriate category of work. For example, if liquidated damages need to be assessed, two separate lines for posting may need to be added (one for the BE work category and one for the other work category). The PE and RE will determine an accurate proportional difference in costs based on engineering judgment if the change order impacts both the BE work and the other work. Cost justifications will need to clearly identify the funding source, or sources for the additional work.
5. Stockpile materials requests will have to be analyzed to determine if the materials will be used on the BE work, the other work, or as a portion of a like item. If the materials are part of a like item, the materials will have to be proportioned and assigned to the appropriate category.
6. Since there is just one contract, retainage is not a concern and can be handled similarly to standard CDOT projects.

CDOT CONSTRUCTION MANUAL

SECTION 200 EARTHWORK

Section 200 EARTHWORK

200.1 GENERAL

Site preparation and earthwork activities on CDOT construction projects should be carefully monitored. This type of work generally involves removing structures and obstructions, clearing and grubbing objectionable and unsuitable materials, excavating and constructing the roadbed embankment, installing temporary and permanent erosion and sedimentation control measures, and handling and disposing non-hazardous and hazardous waste materials. Throughout this type of work, the Contractor is responsible for preserving all protected properties and for complying with all applicable Federal and State laws and local ordinances in accordance with Section 107 of the *Standard Specifications*.

200.2 PRECONSTRUCTION CONSIDERATIONS

The following section presents issues that should be addressed before earthwork begins. Most of these topics should be communicated to the Contractor at the Preconstruction Conference (see Appendix A).

200.2.1 Limits of Construction

The limits of construction define the area in which construction personnel and equipment are permitted to operate. These limits are generally bounded by State right of way. Private property may be involved as discussed in Section 200.2.2. Verify that these limits have been properly staked. Stakes and other markings should be preserved until they have served their useful purpose.

200.2.2 Access to Private Property

Access to private property is obtained on a project-to-project basis. Private property access is permitted only through written agreement between the landowner and Contractor. This agreement will define the limits of access, permitted use, and restoration requirements. The Contractor shall furnish the Project Engineer a copy of this agreement before using private property. Periodically check that points of access to all affected private properties remain open during the project. Contact the Region Right of Way Manager for assistance.

200.2.3 Utilities and Existing Highway Facilities

The schedule and status of any needed utility adjustment or relocation should be carefully reviewed and clearly understood by all affected parties. Contact the Region Utilities Engineer for assistance.

200.2.4 Historical Sites and Markers

Historical sites and historical markers are scattered throughout the State. Verify that protected historical sites and markers within the limits of construction have been properly marked. Check to ensure that the Contractor is fully aware of the importance of preserving these sites and markers during construction. Contact the Region Planning and Environmental Manager for assistance.

200.2.5 Wetland Areas and Animal Habitats

Ensure that protected wetland areas and animal habitats within the limits of construction are clearly staked or otherwise delineated. Inform the Contractor of the sensitivity of these areas and the importance of their preservation. Contact the Region Planning and Environmental Manager for assistance. See Section 107.13.1 for additional information.

200.2.6 Trees and Shrubs

Verify that protected trees and shrubs are clearly staked or otherwise delineated. Contact the Region Planning and Environmental Manager for assistance. See Section 107.13.2 for additional information

200.2.7 Highly Erodible Soils

Where clearing and grubbing is required, the limits of clearing in highly erodible areas will be discussed in the Stormwater Management Plan and defined in the Contract Plans. Verify that these areas are clearly staked or otherwise delineated. During construction, the effectiveness of the Best Management Practices employed for erosion and sedimentation control will be inspected for compliance. Contact the Region Planning and Environmental Manager for assistance (see Section 208.1.2).

200.2.8 Archaeological and Paleontological Sites

Ensure that archaeological and paleontological sites discovered during the Site Investigation are clearly staked or otherwise delineated. Ensure the Contractor understands the importance of preserving these resources. If unforeseen archeological or paleontological discoveries are encountered during construction, the Contractor's affected operations shall immediately cease and the Region Planning and Environmental Manager shall be notified. See Section 107.23 additional information.

200.2.9 Hazardous Operations

As governed by Section 107 of the Standard Specifications, the Contractor is solely responsible for adhering to Federal and State laws and local ordinances with respect to the safety of project personnel and the public. Periodically review construction operations for obvious signs of non-

compliance. Explosives handling, blasting operations, felling of timber, and burning of debris present significant hazards. Immediately notify the Project Engineer of any suspect operation. Contact the CDOT Safety Officer for assistance.

200.2.10 Hazardous Material/Hazardous Waste

Ensure that all suspected hazardous material/hazardous waste sites that have been identified during the Modified Environmental Site Assessment and Site Investigation are properly staked or otherwise delineated. All special requirements of the Contract should be strictly enforced. Also, ensure that the notification flowchart presented in Figure 200A of Section 250.2.5.1 has been completed and posted. Contact the Region Planning and Environmental Manager who in turn will confer with Hazardous Materials in Safety Services and Hazardous Waste in the Property Management Unit. See Section 250.2 for additional information.

200.2.11 Salvable Materials

Salvable materials that become the property of the Department must be carefully removed in sections and properly marked and stored. Where required, check that the Contractor utilizes match markings for the reassembly of structures. Check the provisions of the Contract for special requirements. Verify that the Contractor is aware of the disposition of all salvable material before earthwork activities begin. Inspect materials for damage if they are to be reused on the project. See Section 200.2.2 where materials must be stored on private property.

200.2.12 Stakes and Survey Monuments

Check stakes for compliance with Section 625 of the Standard Specifications and to ensure that all survey benchmarks, monumentation, and stakes are adequately marked and preserved during the project. Contact the Region Right of Way Manager for assistance.

200.2.13 State Noxious Weeds

All mulch, seed, sod, plants, shrubs and other similar biological material must be free from noxious weeds to minimize their propagation. Noxious weeds are plants that are detrimental to the health and well-being of other living organisms within the State, as determined by the Colorado Department of Agriculture state and county noxious weed list. This should be discussed with the Contractor at the Pre-construction Conference and reiterated at Project Progress Meetings before operations such as excavating topsoil, placing topsoil; seeding, sodding, planting, and mulching begin. Contact the Region Environmental Manager or the Region Noxious Weed Manager for additional information.

200.2.14 Visual Documentation

Visual aids can substantially complement the written documentation required by the Department, especially when claims and litigation are anticipated. Prior to and during the project, use cameras and video recorders to document field results.

SECTION 201 CLEARING AND GRUBBING

201.1 GENERAL REQUIREMENTS

Clearing and grubbing are specified on projects to eliminate all unsuitable material from roadway excavation material and embankments. If organic material is allowed to remain, it will rot and create voids within or under the compacted embankment material. As the embankment material settles to fill the voids, a pavement failure will generally occur. In addition, all branches within 20-foot clear height above the subgrade must be pruned and the cut surface properly treated.

201.1.1 Excavation Areas and Borrow Pits

One objective during roadway design is to balance cuts with fills by reusing excavated material further ahead in station to construct embankments; thus minimizing construction costs. The excavated material is not always suitable for use in roadway embankments. In these areas, specially located borrow pits are used for the additionally needed material. Both excavated and borrowed material must not only be suitable in terms of soil characteristics, but also free from organic matter. Clearing and grubbing is typically specified for excavation areas and borrow pits to completely remove organic matter such as trees, undergrowth, stumps, roots, and ground cover.

201.1.2 Embankment Areas

For embankment areas, the treatment of stumps and vegetation depends on many factors as discussed in this section.

201.1.2.1 Fills Greater Than Four Feet

Many contracts require the underlying embankment foundation to be pre-compacted, which necessitates complete clearing, grubbing, and removal of organic ground cover. If pre-compaction is not specified, however, and the fill (i.e., as measured from natural ground line to subgrade) is greater than four feet, the following practice is acceptable:

1. Vegetation. Vegetative matter may be mowed and remain in place.
2. Stumps. Stumps may be cut to a height of six inches above the natural ground and remain in place. One exception to this practice is where the stump is within two feet of the toe of the fill slope, which requires complete stump removal.

201.1.2.2 Four-Foot Fills or Less

For fills that are four feet or less (i.e., as measured from natural ground line to subgrade), the following practice must be followed:

Vegetation. All vegetative matter must be completely stripped.

Stumps. Stumps may be cut to a height within six inches above the natural ground and remain in place. However, there is a condition to this practice: the final embankment must have at least two feet of compacted fill material between the resulting subgrade or side slope and the top of the stump.

201.2 INSPECTION GUIDELINES

201.2.1 Before Construction

Before clearing and grubbing begins, review the preconstruction considerations presented in Section 200.2. In addition, verify acceptability of the Contractor's proposed method of debris disposal.

201.2.2 During Construction

Blasting. Consult the Project Engineer if violations are suspected.

Stumps and Vegetation. Verify that vegetation and stumps are treated consistent with the criteria presented in Section 201.1. Treatment depends on many factors including fill height and location.

Objectionable Material. Verify that objectionable materials are removed and backfilled as specified in the Contract. Ensure that objectionable materials are not mixed with excavated material.

Tree Branches. Verify that tree branches are pruned to the required vertical clearance. Ensure that unsound and unsightly branches are also pruned. Pruning must be performed using good tree surgery practices.

Debris Disposal. Check that debris is disposed of properly and that approved burning operations are performed safely and within legal limits.

201.2.3 After Construction

A newly cleared site is vulnerable to erosion. Check the Stormwater Management Plan and the provisions of the Contract with respect to the Best Management Practices required for erosion and sedimentation control. See Section 208 for additional information.

SECTION 202 REMOVAL OF STRUCTURES AND OBSTRUCTIONS

202.1 GENERAL REQUIREMENTS

All structures and obstructions marked for demolition within the limits of construction must be safely removed and properly disposed. The trenches, holes, or pits resulting from such activities must be backfilled and compacted. Unless otherwise directed, backfill that is placed below or outside the roadway prism (e.g., below subgrade) will be placed and compacted as close as practical to the density of the in situ soil. Backfill placement and compaction within the roadway prism will be performed as specified in the Contract.

202.2 INSPECTION GUIDELINES

202.2.1 Before Construction

Consider the following guidelines before removal of structures and obstructions:

Methods of Removal. Prior acceptance by CDOT of the Contractor's methods of removal may be necessary. Check the provisions of the Contract.

Damage to Structures. Do not allow any construction method or equipment operation to continue if it could damage an adjacent structure or portion of structure designated to remain in place.

Blasting. The handling of explosives and blasting operations will be performed as specified in the Contract.

Measurements. Many items designated for removal will require measurement for payment prior to the actual removal work (e.g., curb & gutter, sidewalk). Measure and mark these items and ensure that the Contractor understands the limits of removal.

202.2.2 During Construction

Salvable Materials. If culverts are to be reused, ensure they are removed without damage and properly stored. See Section 200.2.11 for additional information.

Pavements and Sidewalks. Where the Contract specifies complete removal of pavement, sidewalks, curbs, etc., verify removal to the proper width and depth. Check that the material is disposed of properly. Some contracts may specify material recycling. Check the provisions of the Contract. If partial removal is specified, verify that sawed cut lines are true and maintained.

Basements. Basements and other similar cavities that are left by demolition must be filled and compacted in accordance with the requirements of the Contract. Special attention is needed to achieve uniform density in such areas.

Maintenance of Traffic. Verify that pavement markings are completely eradicated before new traffic patterns are established. Check the Contract Plans for conformance with the Transportation Management Plan. See Section 630 for additional information.

Bridges. Check for removal to the proper depth (e.g., columns, abutments, footings).

202.2.3 After Construction

Items to be removed are sometimes removed in sections or a portion at a time. Where partial removal is necessary, carefully check the site to ensure that the remaining portion of the item does not impose a public hazard or compromise adjacent property (e.g., the remaining structure appears unstable, a section of guardrail is left exposed without proper end treatment). Prior to reopening roadways to traffic, also check that all debris has been removed from the roadway.

202.3 REMOVAL OF BRIDGE

Projects that include bridge removal will include a project special provision titled Revision of Section 202 - Removal of Bridge.

This special provision requires the Contractor to submit a Bridge Removal Plan, parts of which must be signed and sealed by the Contractor's Engineer. The Contractor's Engineer is not required to be on site when bridge removal operations are in progress, but shall be present to conduct daily inspections to certify in writing that the falsework, bracing, and shoring conform to the details of the Bridge Removal Plan. The Contractor's Engineer must inspect the removal operation daily and submit a daily progress report. When an unplanned event occurs, the Contractor's Engineer must submit a report that describes the operation or procedure proposed to remedy the situation. Conditions under which the Engineer may suspend bridge removal are listed in the special provision.

This special provision also requires that a Pre-Removal Conference be held at least seven days prior to beginning bridge removal. Required attendees include the Engineer, the Contractor, the demolition subcontractor, the Contractor's Engineer, and the Contractor's Traffic Control Supervisor. The agenda for the conference is included in Appendix A.

SECTION 203 EXCAVATION AND EMBANKMENT

203.1 GENERAL REQUIREMENTS

Excavation and embankment (i.e., generally referred to as earthwork) is the construction of a graded roadbed, upon which subsequent base and wearing courses are constructed. Excavation is that part of the earthwork that is dug up, hauled, or reused as fill material to construct the embankment portion of the roadbed. Roadway excavation, which is that material obtained from within the right of way exclusive of structural excavation, may be composed of common earth, solid rock, loose rock, or any combination of these materials. Where there exists insufficient quantities of suitable roadway excavation and structural excavation for embankment construction (i.e., cuts do not balance with fills), borrow excavation is specified to make up the difference.

203.1.1 Excavation

203.1.1.1 Types of Excavation

Unclassified Excavation. Unclassified excavation includes all materials encountered regardless of their nature or the manner in which they must be removed.

Stripping. Stripping consists of the removal of overburden or other specified material from pits before the underlying material is excavated for use in the roadway. Stripping also includes replacing the stripped material.

Removal of Unsuitable Material. Removal of any soils or organic materials that are detrimental to the roadway subgrade or subbase.

Rock Excavation. Rock excavation includes all masses of material that cannot be removed without blasting or ripping and all detached stones or boulders having a volume of 0.5 cubic yards or more as determined by physical or visual measurement meet one of the following criteria:

Ripping Test

Seismic Test

Handling Test

Muck Excavation. Muck excavation provides for the removal and disposal of saturated or unsaturated mixtures of soil and organic matter that are not suitable for a foundation material or embankment. Requests for muck excavation payment should be investigated carefully. Contact the Resident Engineer or the Area Engineer for additional guidance.

Borrow Excavation. Borrow excavation consists of approved material, required for embankments or other portions of work, acquired from outside the right of way.

Potholing. Potholing shall consist of exposing and verifying the location of existing utilities at locations as directed.

203.1.1.2 Excavation Near Wetlands

Excavation in and near wetland areas should be carefully monitored for compliance with environmental requirements. Non-permitted encroachment of wetland areas is unacceptable. Such practices may cause permanent damage to these protected areas and result in litigation. See Section 107.13.1 for additional information.

203.1.2 Embankment Construction

203.1.2.1 Embankment Materials

Embankment material consists of approved material from excavation or imported, and placed in embankments. See subsection 203.03 of the Standard Specifications for definitions of soil embankment, rock embankment, and rock fill.

203.1.2.2 Foundation Inspection

Before embankment construction begins, carefully inspect the area that will serve as the embankment foundation. Pay particular attention to areas that have questionable supporting capacity. Where soft or very wet areas are found, consider the following:

Unsuitable Materials. If the material is found to be unsuitable, it must be replaced with a material that is suitable for use as an embankment foundation.

Springs/Seeps. Where springs or seeps are found, underdrain facilities may be required to adequately remove the spring or seepage water.

Poor Surface Drainage. When material becomes saturated due to poor surface drainage, it must be dried.

203.1.2.3 Embankment Uniformity

The importance of uniformity in embankment construction cannot be overemphasized. Practical construction methods that ensure uniformity of material, layer thickness, moisture content, and compactive effort are paramount in achieving a quality embankment. Most roadway failures can generally be traced to a lack of uniformity in the embankment.

203.1.3 Steep Slopes and Transitions

Where embankments are constructed on steep slopes, a good interlock must be achieved between the sloping foundation and the new embankment material. Material interlock can be effectively achieved by plowing, terracing, or benching the foundation slope. Consider the following guidelines:

Vegetation. Vegetation on very steep slopes must be completely removed to prevent the creation of a slip plane between the foundation slope and the new embankment material.

Hard Sloping Surfaces. Slopes that have a relatively hard surface will create a slip plane unless properly treated. Such slopes must be plowed, terraced, or benched to properly key the embankment material as it is placed and compacted.

Existing Embankments. Where existing embankments are widened or raised in terms of grade, plowing, terracing, or benching are used to key the new material into the existing embankment.

Transition Areas. Benching is used in the transition area between sizable cuts and fills. The transition area is the point where a cut section changes to a fill section. Particular attention should be placed in these areas. Failure to provide sufficient transverse benching and uniformity in compaction generally will result in a rough pavement surface at this junction.

203.2 INSPECTION GUIDELINES

203.2.1 Before Construction

In addition to the general preconstruction guidelines presented in Section 200.2, consider the following before excavation and embankment construction begins:

Utilities. Verify the location of utilities and the status of any relocation work. Note any encroachment permits (see Section 200.2.3).

Environmental Considerations. Verify compliance with respect to erosion and sedimentation control, vegetation and tree protection, wetlands, and other environmental requirements including mitigation measures committed to in the Environmental Assessment or Environmental Impact Statement. Make certain that protected wetland areas are marked and communicated to the Contractor (see Section 200.2.5 and Section 200.2.6).

Types of Excavation. Review the types of excavation that will be required for the project (see Section 203.1.1.1). Verify that borrow sites, where used, have been approved and that cross-sections have been taken. Where explosives and blasting are required for rock excavation, verify compliance with the Contract Specifications.

Compaction Considerations. Become familiar with and understand the moisture and density requirements for embankment construction. Check the provisions of the Contract for any required special compaction equipment. Understand the proper operation of such equipment.

Typical Sections/Staking. Become familiar with the typical sections of the Contract Plans. Pay particular attention to required treatments for steep slopes and transition areas (see Section 203.1.3). Verify that slope stakes are properly set (see Section 200.2.12). Visually check staking for obvious irregularities (e.g., off right of way).

Foundation Inspection. Observe the area for unsuitable material and wet spots. Verify removal or treatment based on the direction given by the Project Engineer. Document the locations, quantities, and disposition of materials and treatments. See Section 203.1.2.2 for additional information.

203.2.2 During Construction

Consider the following guidelines during excavation and embankment construction:

Blasting and Explosives. Monitor any handling of explosives and blasting operations for conformance with legal requirements (see Section 200.2.9).

Slide Areas. Be alert to any condition that could indicate a possible slide area.

Slope Stake Preservation. Make certain the Contractor preserves slope stakes and control point references during the operation (see Section 200.2.12).

Clearing and Grubbing. Verify that the site has been properly cleared and grubbed (see Section 201).

Excavated Materials. Observe and report noticeable changes in excavated material with regard to type, texture, and color. Such factors may indicate the presence of unsuitable materials. Verify removal based on directives from the Project Engineer.

Document the locations, quantities, and disposition of such materials. Watch for encounters with materials that could be used elsewhere (e.g., topsoil, riprap). Where topsoil stripping is specified, ensure that topsoil is properly salvaged (see Section 207).

Base of Cut/Top of Slope. Verify that rock encountered at the base of cuts has been excavated to the proper grade. Observe that rounding along the top of cut slopes is performed where specified.

Subexcavated Areas. Ensure that subexcavated areas have been measured for payment before backfilling.

Drainage and Erosion. Verify ditch construction (e.g., typical sections, staking, natural drainage, interceptor ditches at tops of cuts). Watch for damage to the embankment (e.g., unexpected high water with respect to design, improperly drained foundation or roadbed, damage from precipitation). Ensure that the Best Management Practices for water quality control are monitored as required (see Section 208.1.2).

Benching. Verify that slopes and transition areas are being treated as specified with regard to keying the new material (see Section 203.1.3).

Embankment Material. Check to ensure that the embankment is maintained free of organic and frozen materials and uniformly mixed. Rocks, concrete, and asphalt chunks larger than allowable dimensions must be removed and disposed of properly.

Placement and Compaction. Verify that the embankment material is placed in uniform horizontal lifts that do not exceed the allowable maximum thickness. Note the use and permissibility of any end dumping. Observe the compaction operation for uniformity with respect to moisture content and target density. Monitor the operation of specialized compaction equipment for compliance. Check that the top two feet of embankment is constructed with rock free material.

Structure/Pile Locations. Ensure that embankment material is being placed to avoid damage to adjacent structures. Oversize material should not be used around structures or pile driving locations.

Debris Disposal. Roots, logs, and other unsuitable materials must be disposed of in designated areas outside the fill area.

Cross-Sections. Frequently monitor the earthwork cross-section (e.g., width, side slopes, grade) for conformance with regard to tolerance of typical sections.

203.2.3 After Construction

After construction, verify that the roadway grade and prism are within specified tolerance and that embankment construction meets the density requirements of the Contract. Check the installation of drainage facilities for proper operation and that the Contractor maintains the roadbed in proper condition.

203.2.4 Suggested Practices for Avoiding and Mitigating Localized Soft Subgrade Problems Encountered While Paving

The intent of this section is to provide guidance for field personnel in the appropriate remediation of localized soft subgrade encountered during paving operations and after final approval of finished subgrade and proof rolling have been completed in accordance with Revision of Section 203 Proof Rolling.

It is important to note that the Engineer may suspend work at any time the subgrade is not in proper condition for the placing of the sub base, base course or pavement. The best practices listed below are not intended to replace good engineering judgment.

Suggested Practices - Prior to Construction

The Project Engineer and Inspection Staff should review and be familiar with the appropriate pavement and earthwork specifications and the Construction Manual. Some of these sections include Section 203 (Excavation and Embankment), 306 (Reconditioning), 307 (Lime Treated Subgrade), 401 (Plant Mix Pavements), 403 (Hot Mix Asphalt), 412 (Portland Cement Concrete Pavement) and 420 (Geosynthetics).

203.2.4.1 Contractor Methods Statement

At the Pre-Construction Conference, the Project Engineer should request a Methods Statement from the contractor (to be submitted at the Pre-Paving Conference) as to what method(s) he proposes to use to remediate soft subgrade immediately prior to, or during the course of paving operations. The Project Engineer should evaluate the proposed method(s) and discuss with the Contractor. This methods statement should include, but not be limited to the following:

What methods does the Contractor propose to protect the subgrade from excessive traffic (including construction equipment and construction workers' vehicles), weather, etc., after it has been proof rolled, string-lined and approved by the Engineer?

What equipment does the Contractor propose to have available in case remediation becomes necessary?

What materials will the Contractor have available to assist in repairing these soft spots?

During the Pre-Construction Conference, the Project Engineer should add a note to review the Methods Statement prepared by the Contractor during the PrePaving Conference.

203.2.4.2 Prior to Paving

The following items should be discussed in detail during the Pre-Paving Conference:

1. The Contractor's Proposed Methods Statement(s)
2. The Proof Rolling specification.
3. Paving on frozen subgrade or base material will not be permitted.
4. Excessive vehicle traffic should be minimized on the approved subgrade prior to paving.

Pre-Paving Inspection - It is the Contractor's responsibility to construct the work pursuant to the plans and specifications. The Department's inspectors have a responsibility to thoroughly inspect all subgrade in cooperation with the Contractor's forces. The following are a few of the items that should be considered:

1. Check that subgrade/base has been constructed, string-lined and inspected to assure that the required cross-slope, elevation, and alignment has been obtained as required pursuant to the contract.
2. The subgrade shall be shaped to the required grade and section, free from all ruts, corrugations, or other irregularities, and uniformly compacted and approved in accordance with Section 203.
3. Ensure that the specified materials have been incorporated into the work in accordance with Subsection 203.03.
4. Check that the subgrade/base has been compacted to the required moisture/density. Densities will be determined by nuclear methods in accordance with CP 80.
5. During the proof rolling operation, check for soft spots and ruts, and ensure that the contractor corrects these deficiencies. Any soft spots should be corrected before the paving operation begins.
6. Ensure that the work has been adequately protected once the subgrade has been approved in accordance with the specification.

SECTION 206 EXCAVATION AND BACKFILL FOR STRUCTURES

206.1 GENERAL

If the project includes work on structures, excavation and backfill operations will be specified in the Contract.

206.1.1 Contractor Responsibility

Construction requirements for excavation and backfill for structures are specified in Section 206 of the Standard Specifications. The limiting nature of this criteria (e.g., minimum cover over pipe, backfilling evenly on opposite sides of the structure) does not relieve the Contractor from responsibility for failure or damage caused by unsound construction practices. The Contractor also must consider and effectively use the guidance and recommendations provided by product manufacturers and suppliers. CDOT will not consider participating in the repair or replacement of work if the failure or damage is caused by the fault or negligence of the Contractor.

206.1.2 Damage and Failure Considerations

Structural damage and failures can be avoided if sound construction practices are used in the backfill operation. The Project Inspector should monitor the operation for obvious signs of unsound practices and bring any instances to the attention of the Project Engineer.

Factors that typically contribute to structural damage and failures include:

1. the presence of rock in backfill material,
2. uneven backfilling on opposing sides of the structure,
3. backfilling too soon against freshly poured concrete,
4. placement of backfill material in lifts that are too thick,
5. providing insufficient cover over pipe structures, and
6. operating heavy equipment too close to pipe structures.

CDOT Plans and Specifications are designed so that backfilling operations can be accomplished without causing structural damage or failure, if sound construction practices are employed.

For example, the structural integrity of a large diameter steel pipe relies on the side support provided by the compacted backfill material. If this side support is not adequately developed, the structure may fail. Such types of failure can generally be attributed to a lack of uniformity in the compacted backfill material. It is critical that such operations be carefully monitored for compliance.

206.2 INSPECTION GUIDELINES

206.2.1 Before Construction

Contract Plans and Specifications. Review the Contract for any special requirements. Verify and understand the requirements for excavation and the class and quality of backfill material specified. Take cross-sections and profiles, as needed, for verification.

Payment Factors. Upon receipt of the Contract Plans, consider developing a payment factor for each structure (i.e., factor = total trench volume divided by total length of structure). If, for example, an installed pipe differs from the plans in length but not in cross-section, the factor can be used to quickly adjust final pay quantities.

Staking. Check stakes for any irregularities.

Structure Inspection. Compare the Contract Plans to the site. Inspect and note the condition of the structure. Make certain that structural concrete has attained the minimum required strength before backfilling.

206.2.2 During Construction

Unsuitable Materials. Verify that unsuitable materials have been properly excavated and removed. Document the location, quantity, and disposition of the material.

Embankment. Embankment must be completed, where required, for structures located above natural ground.

Excavation Limits. Check excavated limits, dimensions, and grades. Document quantities.

Trenching. OSHA has strict regulations regarding the provision of shoring in trench operations. As required by Section 107 of the Standard Specifications, such operations are entirely the responsibility of the Contractor. Verify that shoring and side slope treatments are being installed where required.

Base of Excavation. The base of excavation must be firm and comply with specified requirements. Check the base to ensure it has been properly drained and prepared for any placement of concrete.

Pipe. Check the adequacy of the pipe bedding and bed treatment, especially where rock is present. Check the direction of flow, camber, cradles, etc. Pushing the pipe out of line or raising the pipe off its bed during backfilling is unacceptable. Pay particular attention to the backfill material. Direct contact with rock greater than two inches may cause failure in steel pipe.

Compaction. Use extreme caution when backfilling and compacting. Stress uniformity. Verify material lifts, moisture, and the compaction operation for compliance. Do not exceed optimum moisture content. Helical pipe has been known to fail where A-6 and A-7 soils are used. Note any quantities that are not consistent with the Contract.

Hazards. During excavation and backfill operations, protruding structures and surface cavities pose significant hazards to workers and equipment. Check that these types of hazards are clearly marked to prevent mishaps and equipment damage.

SECTION 207 TOPSOIL

207.1 GENERAL

Topsoil obtained from below original ground level in fill sections will increase the quantity of embankment material required to complete construction. Topsoil obtained from cut sections will reduce the material available with which to construct the embankment.

207.2 INSPECTION GUIDELINES

207.2.1 Before Construction

Consider the following guidelines before the topsoil operation begins:

Source/Approval. Verify the source and prior approval of the material.

Slope/Depth. Existing slopes must be acceptable. Note the depth desired for topsoil.

Stockpiling. Verify if stockpiled topsoil is a part of the Contract.

207.2.2 During Construction

Consider the following guidelines during the topsoil operation:

Objectionable Material. Check for the proper removal of debris, roots, heavy clay, hard clods, brush, toxic substances, and stones larger than six inches from the area requiring topsoil. Check topsoil at the site for the presence of State noxious weeds. If State listed noxious weeds, seed, or reproductive vegetative plant parts are present, reject the topsoil. Management controls may be required.

Tilling/Scarification. Verify that tilling or scarification is being performed at the specified depth. Check for cross-tilling, where required. Ensure that topsoil is not applied over untilled or unscarified areas.

Distribution. Check that the Contractor is evenly distributing the topsoil at the specified depth.

Compaction. Check the acceptability of the compaction operation. Over-compaction is unacceptable. Pre-compaction will generally become unnecessary when topsoil is obtained from the roadway.

Grading. Check grades and make certain provision is made for adequately draining surface water, especially away from buildings and other improved structures. Check the finished grade for conformance and tolerance.

Seeding Considerations. Verify light rolling, fine grading, raking, and depth of tillage. Observe whether there are excessive clods in seedbeds. Determine the need for discing and harrowing to provide an acceptable seedbed.

207.2.3 After Construction

Check the Stormwater Management Plan of the Contract Plans for the Best Management Practices for erosion and sedimentation control that is required upon completing the placement of topsoil. See Section 208 for additional information.

SECTION 208 EROSION CONTROL

208.1 GENERAL

Erosion control work consists of the construction, installation, maintenance, and removal of erosion control measures. This work prevents or minimizes erosion, sedimentation, and pollution of State waters (including wetlands). Erosion and sedimentation control measures will be constructed and maintained in accordance with the Best Management Practices (BMPs)/control measures designated in the Stormwater Management Plan (SWMP) for the project.

There are many resources available to the Engineer for assistance with erosion control. Additional design information can be obtained from the CDOT Erosion Control and Stormwater Quality Guide and the CDOT Erosion Control and Stormwater Quality Field Guide. In addition, a comprehensive checklist outlining permit compliance requirements that engineers need to know for their projects is available on the MS4 Construction Program Website https://www.codot.gov/programs/environmental/water-quality/stormwater-programs/construction-sites-program/assets/cdot-project-level-ms4-construction-program-compliance-checklist_draft_1-18-22.xlsx.

The Region Water Pollution Control Manager (RWPCM) is the primary day-to-day point of contact for all issues relating to erosion control. Questions related to final stabilization may be directed to the Landscape Architect representing the Region or to the Landscape Architecture Section at CDOT headquarters. For urgent concerns, conflict resolution, or if the RWPCM is unavailable, the Engineer may contact the Regional Planning Environmental Manager (RPEM). Staff within the Headquarters Environmental Water Quality (WQ) section are also available for questions relating to erosion control and water quality.

208.1.1 Erosion and Sedimentation Process

Erosion and sedimentation are natural processes whereby soil materials are detached and transported from one location and deposited in another due to the action of water, wind, ice, and gravity. Erosion can take many forms including sheet, rill, gully, and channel erosion. The erosion potential of a particular area is determined by interrelated factors including soil characteristics, vegetative cover, topography, and climate.

208.1.2 Water Quality Management Requirements

208.1.2.1 Stormwater Management Plan (SWMP)

The SWMP is included on all CDOT projects and will define the temporary construction control measures required for regulatory compliance and water quality control. The SWMP must be prepared by a CDOT-certified SWMP Preparer and reviewed and accepted by a CDOT employed and certified SWMP Preparer. The RWPCM or CDOT Headquarters HQ staff will conduct routine

storm water management inspections during construction and will provide guidance to the Engineer during construction.

208.1.2.2 Control Measures

Best management practices are schedules of activities, avoidances, administrative procedures, and structural and non-structural control measures that are used to control erosion and sedimentation and minimize pollution of stormwater runoff both during and after construction. Details on control measures, including construction and maintenance requirements, are found in Section 208 of the Standard Specifications and Standard Special Provisions (Standard Specifications apply for projects with a stormwater construction permit [SCP], Standard Special Provisions are available for projects without an SCP).

Soil Stabilization Practices. Soil stabilization practices are temporary, interim, and permanent treatments that stabilize and protect exposed earthen surfaces from erosion due to precipitation, overland flow, and run-on conditions. The definitions and requirements of each soil stabilization practice can be found in subsection 208.04(e) of the Standard Specifications and Standard Special Provisions.

Design and construction criteria for specific control measures are presented in the CDOT Erosion Control and Stormwater Quality Guide and the CDOT Erosion Control and Stormwater Quality Field Guide, and in M&S Standards M-208-1 and M-216-1.

208.1.2.3 Erosion Control Management (ECM)

The number of days for Erosion Control Management (ECM) will be specified in the Contract and is based on the Engineer's estimated schedule to complete the project. See subsection 208.03 of the Standard Specifications and Standard Special Provisions for requirements.

208.2 INSPECTION GUIDELINES

208.2.1 Before Construction

An on-site Environmental Pre-construction Conference shall be held, see subsection 208.03 of the Standard Specifications and Standard Special Provisions for requirements. An RWPCM (Region Water Pollution Control Manager) should be invited to participate in the environmental Pre-construction Conference. An example of an Environmental Pre-construction Conference Agenda is in Appendix A. Consider the following guidelines before clearing and grubbing work begins:

Schedule Review. Review the Contractor's schedule for temporary and permanent erosion control measures to ensure proper coordination with other construction activities. Emphasize the importance of this schedule to the Contractor.

Training Requirements. Verify that the individual(s) assigned as the SWMP Administrator and Erosion Control Inspector(s) met the training requirements specified for the Contract, see

subsection 208.3(c) of the Standard Specifications and Standard Special Provisions for requirements.

Stormwater Management Plan. Review the SWMP and fully understand the types and locations of the control measures that are to be employed. Verify that the Contractor fully understands the requirements and intent of the SWMP. Any changes or modifications to the SWMP requested by the Contractor shall be approved with Form 105. Approved 105s related to water quality should be included in the SWMP.

Stormwater Construction Permit. Colorado Department of Public Health and Environment (CDPHE) issues Colorado Discharge Permit System Stormwater Construction Permits (CDPS- SCP) for all projects with disturbance equal to or greater than one acre. Both CDOT and the Contractor will be co-permittees on the CDPS-SCP before construction begins.

208.2.2 During Construction

Consider the following guidelines during the inspection of erosion control work:

SWMP. The SWMP Administrator shall maintain a SWMP as required by Section 208.03(c) of the Standard Specifications and Standard Special Provisions.

Installation Review. Review the installation of the control measures closely, and document the appropriate pay quantities on CDOT Form 266 - Inspector's Progress Report.

Inspection. The Contractor's ECM staff shall routinely inspect the control measures to ensure they are functioning as intended. The minimum formal inspection frequency can be found in subsection 208.03(c)2 of the Standard Specifications and Standard Special Provisions.

Sedimentation. Sediment buildup behind erosion control features shall be routinely removed by the Contractor. Check control measures to ensure that sediment is being removed as required. See subsection 208.04(f) of the Standard Specifications and Standard Special Provisions for requirements.

Soil Stabilization. The Contractor shall conduct temporary, interim, summer and winter, along with permanent stabilization measures as site conditions allow. See subsection 208.04(e) of the Standard Specifications and Standard Special Provisions for requirements.

Unforeseen Conditions. The Contractor shall adaptively manage control measures to effectively minimize polluted storm water discharges from the project site. This may require the Contractor to install control measures that were not originally included in the SWMP, or to modify the standard control measure details. CDPHE defines major SWMP modifications and minor SWMP modifications in the Non-standard MS4 Permit (CDPS Permit No. COR070000). CDOT is adopting these definitions. The RWPCM will review, and may either approve or reject,

all minor SWMP modifications during the next CDOT MS4 Inspection after the SWMP is modified. For major SWMP modifications, the Project Engineer will follow the Contract Modification Order (CMO) process described in this Construction Manual, or another relevant project delivery manual. The Project Engineer should consult with the RWPCM to discuss how the CMO will impact project compliance with MS4 Permit requirements. Any major changes or modifications to the SWMP shall be approved with Form 105. Approved 105s related to water quality should be included in the SWMP. Modified standard details or substantial modifications to the overall SWMP strategy must be approved by the Engineer with recommendations by the RWPCM. Modifications that affect the Permanent Stabilization Site Map shall be approved by the Landscape Architect representing the Region.

Spill Response. Immediately following a spill, the Contractor shall implement their Spill Response Plan. Colorado Water Quality Control Act, Regulation 5 CCR 1002-61 requires the Contractor to report certain spills to CDPHE. If such a spill occurs, the Contractor shall report the spill to the Engineer prior to CDPHE notification. The Engineer should contact the RWPCM for additional assistance.

CDOT's Municipal Separate Storm Sewer Systems (MS4) Permit COS000005. Headquarters and Region water quality inspections are required for all projects with disturbance equal to or greater than one acre as part of the CDOT's MS4 compliance. The RWPCM and/or Headquarters Water Quality section staff will conduct inspections, see subsection 208.09 of the Standard Specifications for requirements.

Corrective Action Response Log. Following CDOT MS4 inspections, the RWPCM or Headquarters Water Quality section staff will document any findings in the online Corrective Action Response Log (CARL) system. Once the findings have been uploaded, the Engineer is responsible for issuing Form 105s to the Contractor to rectify each finding. Form 105s associated with water quality inspection findings must be issued through the CARL system. The Contractor shall correct each finding within the timeframe defined in subsection 208.09 to avoid liquidated damages, work stoppage or other enforcement authorized under subsection 208.09. Once the required corrective action has been taken, the Contractor's SWMP Administrator will be responsible for documenting the corrective action in CARL. If the Contractor provides the documentation, the Engineer must approve or reject it within CARL. For information and CARL access, contact your RWPCM. Access the appropriate CARL at the following links: http://vdtDESCAN.dot.state.co.us/escan/corrective_action_log/index.aspx or <https://2nform.com/>.

Enforcement of Regulatory Permits and Contract Requirements. The enforcement of the CDOT Specifications with respect to water quality is regulated by CDOT's MS4 Permit. See subsection 208.09 of the Standard Specifications for requirements. The following flow chart outlines the MS4 permit enforcement escalation stages and the deferment request option the Contractor has within the first 24 hours of the initial notice of failure to perform.

Figure 200 - 1

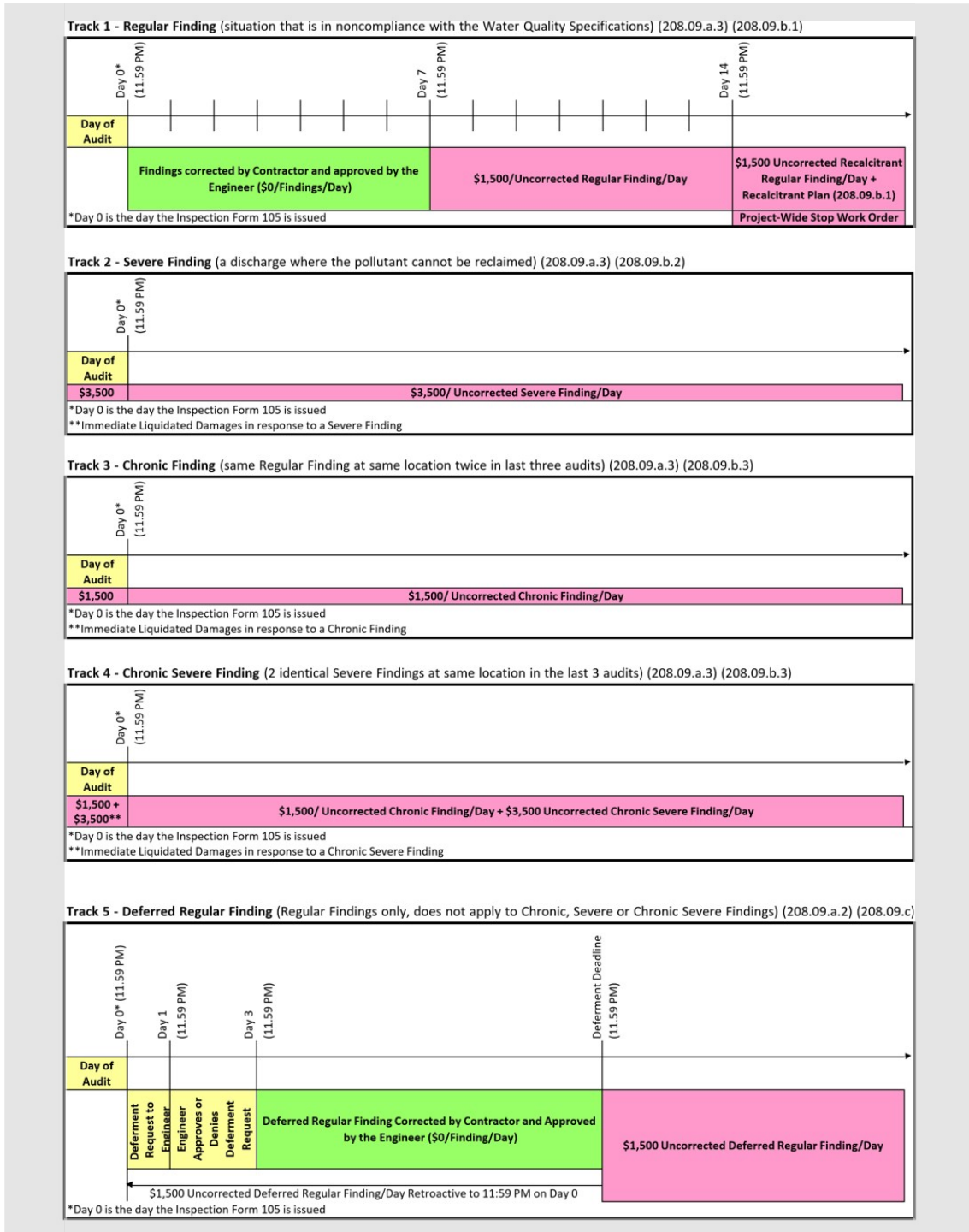

208.2.3 After Construction

Consider the following guidelines after construction:

Removal of Temporary Installations. Upon completion of the project, temporary erosion and sediment control features must be removed by the Contractor as directed by the Engineer, unless biodegradable or otherwise specified by the Engineer.

Partial Acceptance Walkthrough. (Discussed in section 105.21(a)) The Engineer should set up a walkthrough with Region environmental personnel and CDOT Maintenance (or the post construction establishment phase contractor or group). Note the location of any erosion and sediment control measures that will require future maintenance or corrective measure and subsequent removal. If determined necessary, the Engineer should coordinate with Maintenance for further inspections to confirm corrective work has been completed.

When using the CDPS General Permit for Stormwater Discharges Associated with Construction Activity (CDPS-SCP) Transfer to Maintenance Punch List, ensure that all questions, except those listed under the section “Questions for PE/ECM Staff”, are answered “no” or have a corrective work completed associated in the comment section. The corrective action must be completed by the Contractor prior to permit transfer.

Inspections. The Contractor is required to continue inspections until project Final Acceptance. Form 1176 or 1177 (Stormwater Field Inspection Report - Post Construction) must be used to record these inspections.

Closure of Permit. The Engineer will contact the RPEM and RWPCM for the project review to close the permit. The RPEM and RWPCM can check with CDPHE for the most up to date guidance to clarify options available to permittees to achieve final stabilization at construction sites.

SECTION 209 WATERING AND DUST PALLIATIVES

209.1 GENERAL

Water typically is used on projects for such purposes as compaction, seeding, sodding, planting, transplanting, and dust control. Where paid for separately, a complete record of the quantities of water used must be maintained.

209.2 INSPECTION GUIDELINES

209.2.1 Before Construction

Consider the following guidelines before construction begins:

Contract Plans and Specifications. Review the Contract with regard to application rate and any special requirements of the project.

Source Approval. Check to verify that the source of material has been properly approved.

Haul Trucks/Quantities. Establish the method of measuring and documenting quantities. Establish truck identifications, determine, and record the capacity of each haul truck to be used on the project for load count and documentation purposes.

Water Meters. Obtain the necessary water meter certifications in accordance with subsection 209.02 of the Standard Specifications. Retain these certifications in the project records. Ensure that meters are as close to the distribution point as practical. Verify that the outfall pipe from the meter is full and operating under the required pressure. Note any leaks.

Soil Classification/Application. The Project Inspector and the Project Engineer should discuss the soil classifications, required application rate, and equipment operation. Application must be uniform. Be alert to small and remote areas that are difficult to water.

209.2.2 During Construction

Consider the following guidelines during construction:

Runoff/Ice. Note the presence and approximate quantity of runoff when prewetting. In cold weather, watch for excessive ice buildup.

Small Areas. Check small and remote areas to ensure they are not missed. Moisture content in the soil material must be uniform.

Verify Calibration and Quantities. Verify the calibration of equipment and the quantities reported. Watch for loads being spread or dumped in unauthorized places. Compare daily totals with daily production and note any wasting. Immediately investigate unexplained variations.

209.2.3 After Construction

Pay particular attention to locations where water has ponded and where excessive runoff has caused erosion. Areas of ponding indicate possible problems with the finished subgrade. These problem areas could be either a design deficiency or a deficiency on the Contractor's part. Investigate these situations because such areas may need mitigation with temporary erosion control treatments (see Section 208).

SECTION 210 RESET STRUCTURES

210.1 GENERAL

Unserviceable material will be replaced with new material when the Project Engineer determines that this is necessary. New material required for this pay item will be paid for in accordance with subsection 109.04(b) of the *Standard Specifications*. Guardrail and signposts are two of the most common items requiring new material and/or hardware where reset. Make certain that the items needing replacement were not damaged by Contractor personnel.

210.2 INSPECTION GUIDELINES

210.2.1 Before Construction

Consider the following guidelines before barriers (e.g., guardrail, concrete barriers, transitions, and end treatments) are reset or installed:

1. Stakes. Check that stakes are set in their proper location.
2. Contract Plans and Specifications. Review the Contract and become familiar with the installation requirements of the particular type of guardrail being reset or installed. Also, note any requirements for concrete barrier, transitions, and end treatments. Note any peculiar material requirements.
3. Materials. Verify the condition of existing and new materials. The materials must be clean, sound, and serviceable. Verify that the Contractor has furnished the necessary Mill Test Reports and that hardware meets specified requirements. Check the adequacy of any shop bent rail. Verify that concrete and reinforcing steel for concrete barriers meet specified requirements.

210.2.2 During Construction

Consider the following guidelines during the resetting or installation of barriers:

1. Storage and Handling. Materials and hardware must be properly stored and handled to avoid damage. Verify the proper repair and recoating of damaged material. Review and verify compliance with the storage provisions of the Contract. Verify proper disposal of unusable materials and the storage and safekeeping of salvable materials.
2. Posts. Ensure that posts of different types are segregated by groups. If a post has been cut, check that the surface has been properly treated. Make certain that voids under posts are filled with concrete mixture, where required. With respect to meeting Contract requirements, consider the following additional factors when inspecting posts:

- a. type of posts and blockouts required (wood or steel);
 - b. laboratory inspection requirements for wood posts;
 - c. post and blockout dimensions;
 - d. procedures and tolerance for setting posts with respect to rail height;
 - e. backfilling requirements (i.e., material and procedure);
 - f. required treatment for cut posts; and
 - g. requirements for nailing blockouts in place.
3. Unserviceable Items. The Contractor may be reimbursed for furnishing new material for reset items that are not usable. Make sure that damaged items are not the fault of the Contractor. Such damaged items will be restored, repaired, or replaced at the Contractor's expense.
 4. Rail Height. It is critical to check that the height of rail is being reset to that specified in the Contract Plans.
 5. Protection of Traffic. Verify that the Contractor is providing adequate protection to the traveling public from sections that are not complete. Check that installation proceeds in the direction specified. Verify the proper direction of rail lapping. At the end of the workday, check that rail ends have been properly addressed.
 6. Assembly. Verify compliance with the Contract Plans and Specifications. Check washers, bolts, and rail horizontal and vertical alignment. Check that bolts extend beyond the nuts and are being securely tightened. Verify that the rail is being installed in a smooth, continuous vertical and horizontal alignment.
 7. Deadmen. Where deadmen are required, verify proper installation.
 8. Concrete Barriers. Consider the following during the inspection of concrete barrier installation or resetting:
 - a. Concrete Finish. Inspect the finishing of the concrete for compliance.
 - b. Lift Holes. Verify that lift holes in precast sections are being filled with approved material where required.
 - c. Trench/Base. Check trench construction for cast-in-place barriers, or the base for precast barriers, for compliance with the Contract Plans.

- d. Alignment. Check the longitudinal alignment of the barrier with a 10-foot straight edge for conformance.
 - e. Transition. Verify the connection between the concrete barrier and the guardrail for compliance. Different types may be specified.
9. Reflectors. Check that the reflector tabs are being installed as specified.

SECTION 212 SEEDING, FERTILIZER, AND SODDING

212.1 GENERAL

Seed, fertilizing, and sodding are specified on projects for both landscaping and erosion and sedimentation control purposes. Contact the Landscape Architect assigned to the Region for further information.

212.1.1 Landscape Applications

For landscapes to be successful, proper topsoil preparation, adequate fertilization, healthy plants and quality seed material, judicious watering, and proper follow-up care must be performed.

212.2 INSPECTION GUIDELINES

212.2.1 Before Construction

Consider the following guidelines before seeding, fertilizing, and sodding are performed:

1. **Seed Material.** Verify the mixture, names, purity, germination, weed content, and date of last test on seed labels for compliance. Retain seed labels and vendor statements for the project records. Verify certification requirements (i.e., Contractor furnished, laboratory tests). Verify that the pure-live-seed content has been determined based on the formula in the Contract Specifications. Check condition of seed for water, insect, and mold damage. Enforce the provisions of the Contract with respect to rejection. Ensure the mixture is free from weeds included on the State Department of Agriculture and the State and county noxious weeds list (see Section 200.2.13).
2. **Fertilizer Material.** Check the bag label for compliance with respect to mixture type (e.g., pellet or granular), percent, and class. Retain labels for project records. Check certification requirements (e.g., Contractor furnished, soil tests). Verify that the fertilizer is delivered in unopened containers.
3. **Mulch Material.** Where mulch is required, see Section 213.
4. **Plant Material.** Where plants are required, see Section 214.
5. **Sod Material.** Verify from grower certificates that sod is of the correct species. Retain certificates for the project records. Make certain the rectangular sections of sod have uniform widths, retain native soil on roots, and are the specified thickness. Sod should be placed within 24 hours of being cut. Check to ensure sod is maintained in moist condition.

6. Seeding Coverage. Check coverage of seeding.
7. Surface Preparation. Spot check the prepared soil to ensure that the top four inches or specified depth has been prepared as required.
8. Application Rate. Verify the application rate of seed, fertilizer, and water for the operation.
9. Seasonal and Geographical Location Considerations. Verify the season of the year and the geographical location for compliance with respect to seeding, planting, etc. The Project Engineer may waive specified requirements. Do not permit seeding or planting on consistently frozen ground.
10. Watering/Maintenance. If specified, ensure that the irrigation or sprinkler system is completed and inspected.

212.2.2 During Construction

Consider the following guidelines during seeding, fertilizing and sodding:

1. Application Rates. Check for even distribution and rate of application for seed, fertilizer, water, etc. Check coverage of seed in remote areas.
2. High Wind. Watch for loss of seed and fertilizer in high winds and, as necessary, postpone application.
3. Quantity Checks. Check total quantities of seed or fertilizer used against the acreage covered. Retain empty bags until the number is recorded.
4. Drill Seeding. Verify that drill seeding is being performed at right angles to the slope. The seed should be drilled or sown to provide a 0.25-inch cover.
5. Fertilizer Treatment. Verify that the fertilizer is being worked into the top four inches of soil.
6. Mulching, Weed Free. Where mulch is required, see Section 213.
7. Mulch Tackifier. Ensure that the application rate is in accordance with the Contract Specifications.
8. Planting. Where plants are required, see Section 214.
9. Sod. Sod is to be fertilized after laying is completed and before soaking.

10. Maintenance. Seeded areas should be inspected frequently. Areas with failures must be repaired and reseeded.

212.2.3 After Construction

Check the Contract Specifications for landscape maintenance requirements.

SECTION 213 MULCHING

213.1 GENERAL

Mulching is specified on projects for both landscaping and erosion and sedimentation control purposes. In the context of erosion and sedimentation control, mulching is a soil stabilization Best Management Practice that protects the soil surface from raindrop impact and overland flow or runoff. Mulching generally consists of the application of plant residues or other suitable material to the soil surface. Typical mulching material includes straw, hay, and wood cellulose fiber and must be weed free. Contact the Landscape Architect assigned to the Region for assistance.

213.1.1 Material Certification

Proper weed-free certification must accompany all mulch material before it is used within State right of way. The purpose of this certification is to prevent State noxious weeds from entering the State as discussed in Section 200.2.13. Verification of compliance is performed through visual inspection. All bales shall have one of the following, to indicate material acceptability:

1. one of the bale ties is orange and blue twine;
2. one of the bale ties is specially produced, shiny galvanized wire; or
3. a Regional Forage Certification Program Tag, with appropriate certification number, is attached to the bale.

Do not allow the Contractor to unload any quantity of straw or hay or remove any identifying twine, wire, or tag before inspection by the Project Engineer. Also, ensure that the Contractor supplies the transit certificate that has been signed by both the grower and a duly authorized representative of the Colorado Department of Agriculture.

213.2 INSPECTION GUIDELINES

213.2.1 Before Construction

Consider the following guidelines before the weed-free mulching operation begins:

1. Contract Plans and Specifications. Review the Contract for the areas to be treated and any special requirements
2. Slopes/Staking. Verify slope adequacy and any staking for the areas to be mulched. Ensure the Contractor fully understands the limits of mulching.

3. **Mulching Method.** Understand the proper operation of the mulching method that will be used (e.g., mechanically crimped, hydraulic).
4. **Materials.** Verify that the proper type of mulch has been provided. Check mulch for freshness. It should be expandable and springy. Reject mulch that is discolored, brittle, rotten, moldy, or decayed. At a minimum, 50 percent of the mulch, by weight, should be 10 inches or more in length. Retain supplier certificates indicating dry weight for the project records. Hay should consist of native grasses free of State noxious weeds. Straw should consist of clean cereal shafts that are free of weeds that are named on the Noxious Weeds List. Tackifier will be a free flowing non-corrosive powder without mineral filler, recycled cellulose fiber, clays, or other substances that will inhibit plant growth.
5. **Application Rate.** Verify the specified rate of application for the type of mulch material and the method of application to be used.

213.2.2 During Construction

Consider the following guidelines where mulching is performed:

1. **Application.** Applied mulch depth should not be less than one inch and not more than two inches. The mulch should be uniformly applied in accordance with the Contract specifications. Compare weight certificates against the area mulched to determine if the mulch was applied at the specified rate.
2. **Anchoring.** Check method of securing mulch to the ground and depth of anchoring. Hay and straw mulch should be anchored to the soil surface using a tackifier, blanket, or net, or with a mulch crimping machine. Mechanical anchoring, or crimping, is preferred and recommended for slopes flatter than 2:1. Blankets or nets on slopes steeper than 2:1 should be anchored to the soil.
3. **Tackifier Slurry/Application.** Tackifier used for anchoring is generally applied in a slurry with water and wood fiber (e.g., 100 pounds of powder/150 pounds of fiber/700 gallons of water). Application rate of the powder should be between 80 to 200 pounds per acre.
4. **Seeding.** Mulch should be applied immediately after seeding.
5. **Mechanical Method.** Consider the following factors where a mechanical application method is used:
 - a. uniformity of application (i.e., hay, straw);
 - b. crimping method;

- c. application within 24 hours of seeding; and
 - d. areas designated for burlap or blanketing.
6. Hydraulic Method. Consider the following factors where a hydraulic application method is used:
- a. quantity proportions in slurry tank;
 - b. uniformity of application; and
 - c. mulching area free from surface water.
7. Maintenance. Inspect frequently and reapply mulch where necessary.

213.2.3 After Construction

Check the Contract Specifications for maintenance requirements.

SECTION 214 PLANTING

214.1 GENERAL

Planting is specified on projects for landscaping, erosion, and sedimentation control purposes. Contact the Landscape Architect assigned to the Region for needed assistance.

214.2 INSPECTION GUIDELINES

214.2.1 Before Construction

Consider the following guidelines before the planting operation begins:

1. Planting Layout. Review the planting layout that is included in the Contract.
2. Utilities. Verify that planting locations have been properly coordinated with existing utilities and any utilities that will be adjusted or relocated. Also consider any proposed utilities.
3. Plant Types. Check that plants have been properly labeled regarding species and variety with respect to the requirements of the Contract Plans. Verify that the specified types and sizes are provided according to the Plant List in the Contract.
4. Plant Condition. Check quality and size against the requirements in *American Standards for Nursery Stock*, Contract Plan tabulations, and the Contract Specifications. Verify that the plants supplied are healthy with well-developed branch and root systems. Reject all plants on which roots have become dry or damaged. Check foliage for wilting or dryness. Observe any obvious signs of insect or other damage. Verify balled and burlapped plants for a solid ball that conforms to specified dimensions. Check for broken, cracked, soft or pliable balls. Such types of damage are general grounds for rejection.
5. Certification. Check plants, trees, shrubs, vines, and ground cover for compliance. Check the certificates of inspection for plants, trees, and shrubs (e.g., inspected at nursery, Contractor-furnished samples). Do not accept plants without certificates. Retain certificates for the project records.
6. Season. Check that the planting will be performed during the appropriate season. Verify whether the plants should be balled and burlapped or container grown.

214.2.2 During Construction

Consider the following guidelines during the planting operation:

1. Shipping/Handling. Check that the shipping and handling of plants are meeting specified requirements. Check for any damage caused by shipping and handling.

2. **Plant Location.** Check that trees and shrubs are planted according to the Contract Plans, especially with regard to the required roadway clear zone and sight distance. Check for any conflicts with utilities or underground and overhanging structures, and have plants relocated where necessary.
3. **Ground/Plant Preparation.** Verify that the soil has been properly prepared with the proper type and quantity of soil conditioner and fertilizer. Check that the type of material used for this purpose has been properly approved. Check depth and diameter of planting hole and spacing in beds. Topsoil and soil preparation are generally rototilled prior to planting ground cover type plants.
4. **Plant Preparation.** Observe the preparation of plants. Plants must be prepared according to specified requirements (e.g., soaked, unwrapped). Pruning must be performed using good tree-surgery practices.
5. **Backfill.** Check that plants are properly backfilled with the specified soil conditioner and fertilizer. Saucers are to be covered with approved moist wood chip mulch.
6. **Staking.** Deciduous and coniferous trees generally should be staked for stabilization purposes. Verify that trees are staked as specified. Verify staking locations based on prevailing wind direction. Check that the operation is being performed without damage to the tree (e.g., damage from guy wires), and that the tree trunks are being wrapped as required.
7. **Maintenance.** Verify that the Contractor provided for watering and maintenance of the plants as specified in the Contract.

214.2.3 After Construction

Check the Contract Specifications for maintenance requirements.

Landscape Establishment Incentive:

When a force account item for Landscape Establishment Incentive is included in the contract, the dollar amount of the incentive will be transferred to a CDOT escrow account prior to project final acceptance. Project Engineer will contact the Finals Administrator and the Landscape Architect assigned to the Region for assistance when the Landscape Incentive provision is included in the project plans.

Landscape Establishment Incentive

1. The Landscape Establishment period begins upon receipt of the written “Notice of Landscape Completion” from the Engineer and lasts for a period specified in the 214 Landscape Establishment.
2. Project Engineer transfers dollar amount in the Force Account item- Landscape Establishment Incentive to the CDOT escrow account. Dollar amount is based on the Engineer’s Estimate cost of the Item 214 pay items included in the incentive.

3. Ensure that dead plant material is removed within 30 days after notice during the Landscape Establishment period.
4. Conduct Landscape Establishment Inspection with Contractor and CDOT representatives during the time period specified in the specification.
5. Project Engineer determines amount of Incentive based on the results of the inspection.
6. Project Engineer notifies the Finals Administrator who will coordinate with Project Accounting to pay the authorized amount of Incentive (if any).
7. Contractor replaces plant material determined to be unacceptable (dead or extremely distressed) at end of Landscape Establishment Period.

SECTION 215 TRANSPLANTING

215.1 GENERAL

Transplanting is specified on projects for both landscaping and erosion and sedimentation control purposes. Salvable trees and shrubs that can be transplanted to other locations on the project will be designated in the Contract Plans. Contact the Landscape Architect assigned to the Region for needed assistance.

215.2 INSPECTION GUIDELINES

215.2.1 Before Construction

Consider the following guidelines before the transplanting operation begins:

1. Contract Plans and Specifications. Review the Contract for any special requirements of the operation. Verify plant dormancy requirements before transplanting.
2. Marking/Staking. Verify that trees and shrubs to be transplanted have been properly marked and that information has been communicated to the Contractor. Fully understand those plants that are to remain (i.e., marked for protection, trimming, targets for grubbing).
3. Utilities. Verify that transplanting locations have been properly coordinated with existing utilities and utilities that will be adjusted or relocated. Also consider any proposed utilities.
4. Season. Check that the transplanting will be performed during the appropriate season.

215.2.2 During Construction

Consider the following guidelines during the transplanting operation:

1. Roots. Verify that the root system of the plants is being properly pruned, and that the minimum diameter of the balled root system is being maintained.
2. Spraying. Check that plants are sprayed as specified in the Contract. Pay particular attention to the type of spray being applied and any special precautionary measures that are required. Spraying should not be performed in high winds.
3. Pits. Verify that plant pits are the appropriate size. Check that trees remain in the machine spade ready for transplant and that the pits are sufficient in dimension for the machine-dug root ball.
4. Backfill. Check that backfill is being properly worked and watered.

5. Water Basins. Verify that water basins are of appropriate capacity and filled with water at proper intervals.
6. Saucers. As specified, check that saucers are being covered with approved moist wood chip mulch.
7. Fertilizer. Check that the type and application rate of fertilizer conforms to specified requirements.
8. Schedule Considerations. Plants should generally be transplanted the same day they are removed from the ground.
9. Maintenance. Check that transplanted trees and shrubs are being maintained properly and watered as specified in the Contract.

215.2.3 After Construction

Transplanted trees shall be subject to a 180-day maintenance period. Guying material shall be removed after the 180-day establishment period

SECTION 216 SOIL RETENTION COVERING

216.1 GENERAL

Soil retention covering (“blankets”) is typically specified on projects for the purpose of erosion and sedimentation control. In this context, soil retention covering are used to stabilize the soil and protect it from raindrop impact and overland flow or runoff. Areas to be treated will be designated in the Contract Plans. Contact the Landscape Architect assigned to the Region for assistance.

216.2 INSPECTION GUIDELINES

216.2.1 Before Construction

Consider the following guidelines before soil retention covering is placed:

1. Contract Plans and Specifications. Review the Contract for the type of material to be used and any special requirements of the operation.
2. Marking/Staking. Verify that areas to be treated have been properly marked or staked. Ensure the Contractor fully understands the limits of treatment.

216.2.2 During Construction

During construction, verify that blanket material conforms to specified requirements and is placed in the areas designated for treatment. Verify the correct placement of blankets with respect to unrolling and overlapping requirements. Ensure that the blankets are being maintained properly.

SECTION 217 HERBICIDE TREATMENT

217.1 GENERAL

Herbicide treatment is typically specified to eradicate or otherwise control plant material on the project right of way or control weeds that are listed on the Noxious Weeds List. Areas to be treated will be designated in the Contract Plans. Contact the Landscape Architect assigned to the Region for assistance.

217.2 INSPECTION GUIDELINES

217.2.1 Before Construction

Prior to construction, the Region Maintenance Noxious Weed Coordinator should be notified of the location and time when spraying will be performed. Consider the following guidelines before herbicide treatment is performed:

1. Contract Plans and Specifications. Review the Contract for the type of herbicide to be used and any special requirements.
2. Marking/Staking. Verify that the areas to be treated have been properly marked or staked. Ensure the Contractor fully understands the limits of treatment.
3. Safety Precautions. Fully understand the safety precautions for the particular herbicide to be used. Verify that the Contractor understands these requirements.
4. Material/Labels. Check that the type of herbicide provided meets the specified requirements. Verify the herbicide is properly labeled and the Contractor has furnished the necessary label information. Retain the label information in the project files.
5. Licensing. Verify that the Contractor has furnished the required documentation regarding applicator licensing. Retain this documentation in the project records.

217.2.2 During Construction

Consider the following guidelines during herbicide treatment:

1. Mixing/Application. Verify that the Contractor mixes and applies the herbicide in accordance with the manufacturer's recommendations.
2. Weather Conditions. Verify that the weather conditions are appropriate for application. Herbicide should not be applied during high winds. Review the manufacturer's recommendations for adverse weather conditions.
3. Overspray. Check that the Contractor's methods of controlling overspray meets specified requirements

SECTION 250 ENVIRONMENTAL, HEALTH, AND SAFETY MANAGEMENT

250.1 GENERAL

This section provides environmental, health, and safety management considerations related to contaminants that may be encountered on the project. Section 107 and Section 250 of the *Standard Specifications* govern the Contractor's obligations and legal responsibilities for related topics.

250.2 HAZARDOUS MATERIAL/HAZARDOUS WASTE

250.2.1 Governing Specifications and Procedural Directives

Where hazardous materials and hazardous wastes are encountered, Section 250 of the *Standard Specifications* will govern the actions and activities of all construction personnel. Review *CDOT Procedural Directive 89.2 - Medical Monitoring for Hazardous Materials Workers* to identify which CDOT personnel assigned to the project will require medical monitoring, and become familiar with the monitoring procedures. Contact the CDOT Safety Officer of the Office of Transportation Safety for assistance.

250.2.2 Site Investigation

If hazardous materials and/or hazardous waste have been identified within the proposed limits of construction, such areas will be designated in the Contract. Verify that the Contractor has been properly informed with respect to site location and special requirements. Check that such areas are clearly marked.

250.2.3 Importance of Records and Documentation

It is important that complete and accurate records and documentation be maintained throughout the course of processing a hazardous material or hazardous waste discovery. Written notes, reports, detailed cost records, photographs, and videos all should be considered. Such records will assist CDOT in cost recovery and possible litigation.

250.2.4 Create Notification Form for Emergency Response

When the project first starts, the Project Engineer will prepare a list of contact names and telephone numbers to use in the event of a hazardous material/hazardous waste situation. Figure 200A presents a form for the recommended flow of notification. Complete and post this form in an obvious location within the project field office.

250.2.5 Discovery During Construction

Where hazardous materials are discovered during construction, pay particular attention to the encounter and treat each situation uniquely. Use common sense, remain calm, and stay alert.

Use the procedural flowchart in Figure 200B to mitigate and contain the situation and obtain the needed assistance from hazardous-material experts and specialists (e.g., CDOT Staff, CDOT Hazardous Materials Consultants, State and local health officials). The following sections loosely correlate with the steps in the flowchart.

250.2.5.1 Potential Discovery Situations

Be aware of the possibility of encountering a hazardous material/hazardous waste situation during construction. Upon discovery of a potential hazardous substance, do not open any closed container or otherwise attempt to identify the substance. Halt work, and follow the flowchart procedures in Figure 200B. Immediately notify the proper authorities (see Section 250.2.5.4). Consider the following:

Earthwork

PROJECT NUMBER: _____

LOCATION: _____

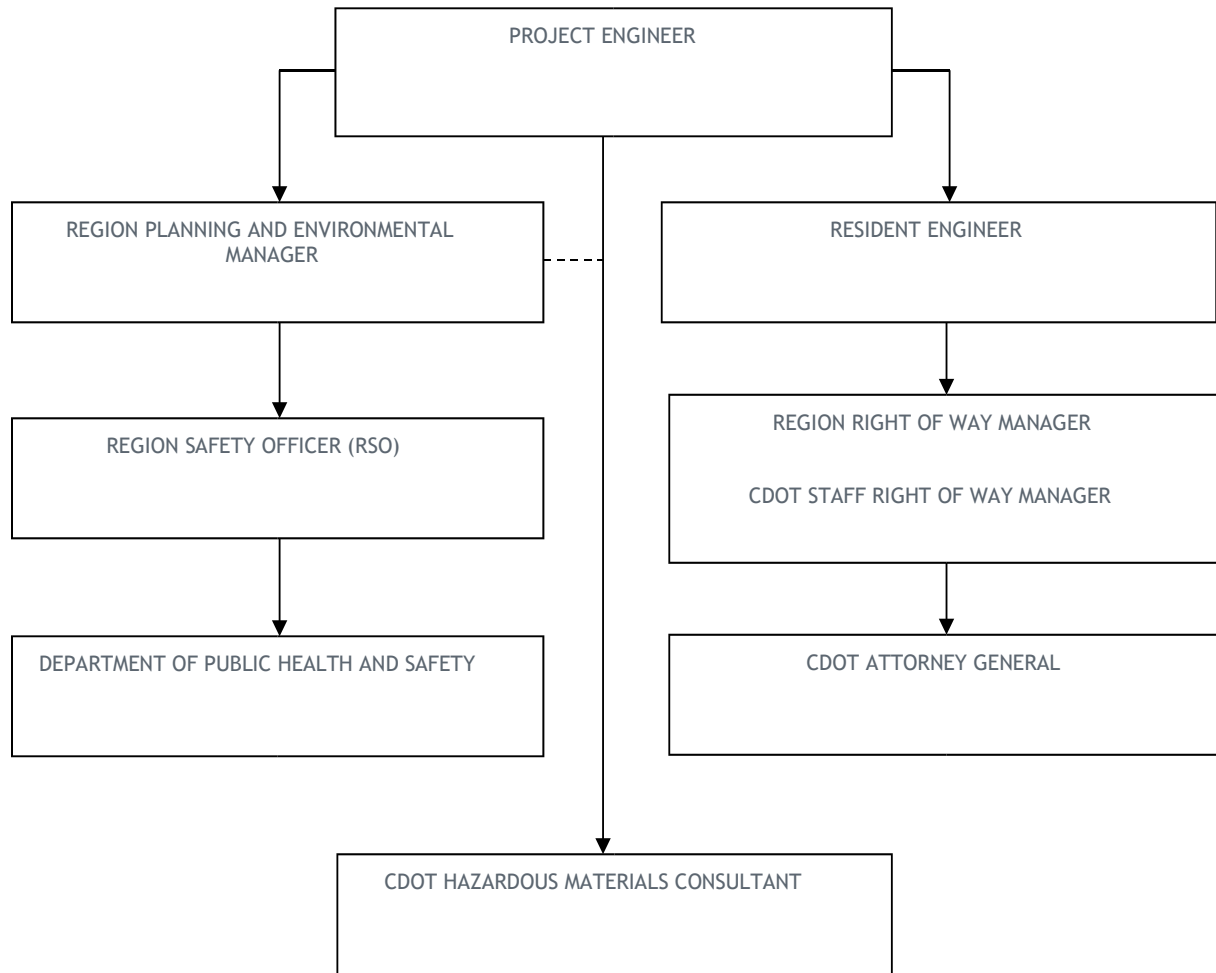

EMERGENCY RESPONSE PHONE NUMBERS:

Emergency Notification (where available) 911
 State Patrol - Dispatcher (24 Hours) (303) 239-4501
 State Patrol - Local (24 Hours) _____

Figure 200 - 2 Notification Form for Contact Numbers for Hazardous Materials Situations Encountered During Construction

Earthwork

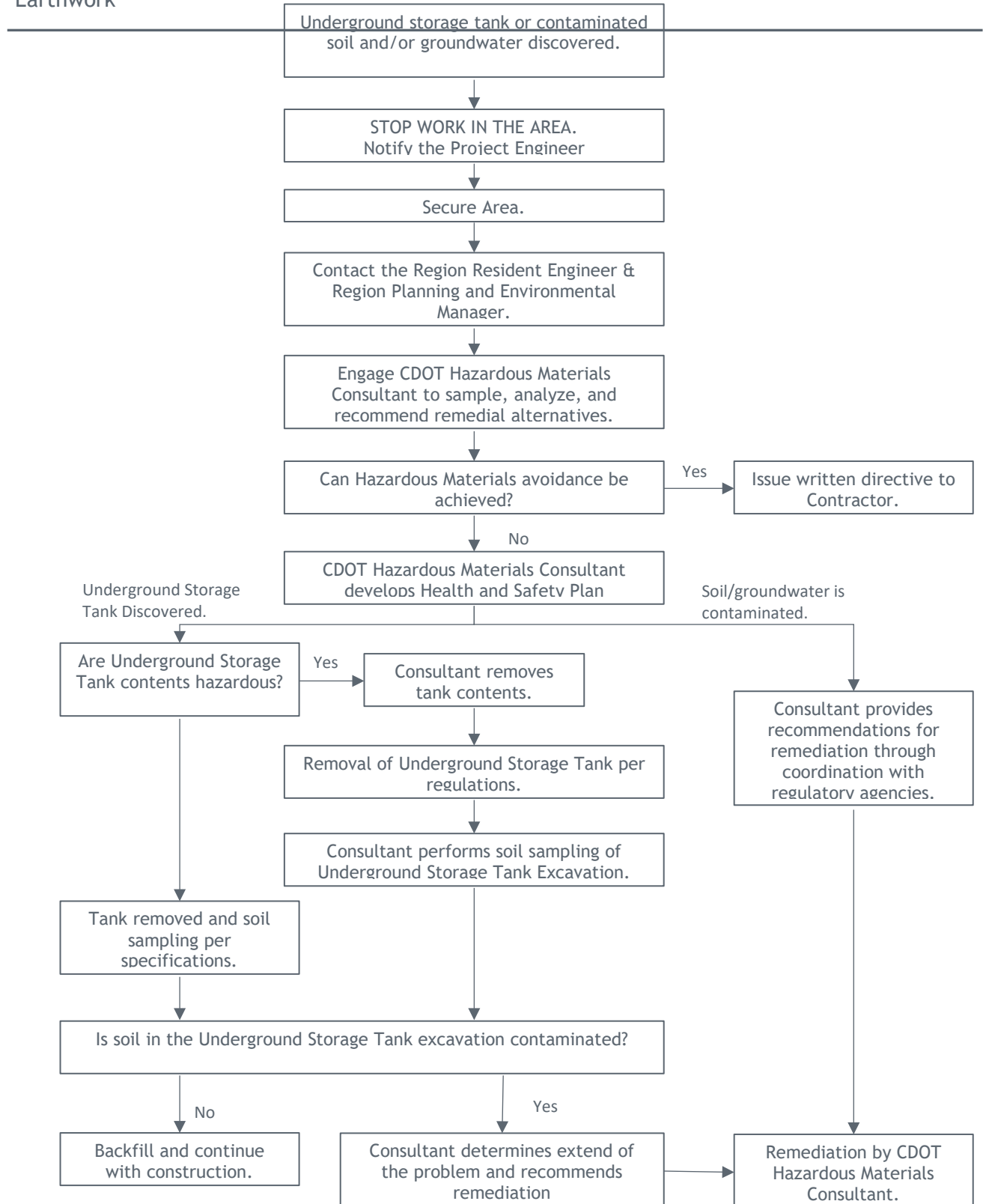

Figure 200 - 3 Procedures for Hazardous Material/Hazardous Waste Situations Encountered During Construction

1. Excavation. Hazardous substances could be encountered during excavation. Treat all underground storage tanks, buried containers, and suspect soil and groundwater as potential hazards. Obnoxious fumes, unusual odors, discolored soils, water surface sheen, and visible fumes and smoke are key indicators.
2. Illegal Dumping. Be aware that hazardous materials could be illegally dumped within the right of way during off-shift hours. Use common sense and collaborative judgment to assess the nature of the encounter. Treat suspect containers and materials as potential hazards.
3. Construction Mishaps. Construction personnel and equipment operations could inadvertently rupture a natural gas or petroleum pipeline or cause a large fuel or chemical spill. Treat such incidents as a hazardous-material situation.

250.2.5.2 Stopping Work

Upon discovery of a suspect substance, immediately notify the Project Engineer. A written directive using Form 105 to stop work near the suspect substance will be issued to the Contractor. This action is necessary to avoid health risks to all personnel at the site and the general public. Health and safety take precedence over construction costs and delays. People who have come into direct contact with suspect substances (e.g., skin contact, inhalation) or exhibit adverse reactions should receive immediate attention by authorized medical personnel. People who have been exposed to suspect substances also should be monitored for adverse delayed reactions based on the recommendations of authorized medical personnel.

250.2.5.3 Securing the Area

After work has been stopped, the area surrounding the suspect substance must be secured to prevent inadvertent or unauthorized access by personnel or the public. Treatments generally consist of cordoning the area, installing temporary fencing, and/or rerouting traffic patterns. Specific actions will depend on the scale, severity, and nature of each situation. In addition, each situation will require appropriate administration of the Contract. After the area has been properly secured, the Project Engineer should consider practical alternatives for the Contractor to continue work on the project. If unavailable, document work delays, because Contractor negotiations may be necessary.

250.2.5.4 Emergency Contact Notification

In a situation where an extremely hazardous or life-threatening substance is encountered, immediately notify the following:

1. 911 Emergency Response (where available);
2. Colorado State Patrol 24-hour line at (303) 239-4501;
3. local fire department; and

4. Colorado Department of Public Health and Environment, Emergency Response Section at (303) 756-4455.

A coordinated effort is necessary to properly address each hazardous material/ hazardous waste situation. To provide continuity within the project, the Project Engineer should always be kept informed. It is extremely important to maintain complete and accurate records (e.g., contacts made, recommendations, decisions, planned and completed activities, schedules). Figure 200A presents the minimum recommended notification procedures. Key contacts are as follows:

1. Project Engineer. After the Project Engineer has been notified, the Project Engineer will contact the Region Resident Engineer and the Region Planning and Environmental Manager. The Region Planning and Environmental Manager will provide guidance regarding the handling of suspect hazardous materials. Do not permit suspect soils that have been excavated to be rehandled unless otherwise recommended by the Region Planning and Environmental Manager.
2. Region Planning and Environmental Manager. The Region Planning and Environmental Manager will contact CDOT Hazardous Waste Staff in the Property Management Unit of the Maintenance and Operations Branch. As needed, the Region Planning and Environmental Manager will contact:
 - a. CDOT Safety Officer in Office of Transportation Safety/Statewide Safety Officer;
 - b. CDOT Environmental Programs Branch of the Division of Transportation Development;
 - c. Emergency Response Section of the Colorado Department of Public Health and Environment; and
 - d. other State and local health and regulatory agencies, as needed.
3. Region Resident Engineer. The Region Resident Engineer or, as directed, the Project Engineer will contact the Region Right of Way Manager for assistance in investigating the substance encroaching private property, originating source of the material, and ownership.
4. Region Right of Way Manager. The Region Right of Way Manager will coordinate with the CDOT Staff Right of Way Manager in Right of Way Programs of the Project Development Branch to determine if it is necessary to contact the CDOT Office of the Attorney General with regard to liability, cost recovery, and documentation issues. If a claim against the State Petroleum Fund is probable, contact Environmental Programs for guidance on record maintenance for the reimbursement application.
5. Other Notifications. Other notifications may be necessary as follows:
 - a. Office of Public Relations. The CDOT Office of Public Relations should be notified in the event of any situation adversely affecting the public or if media

involvement is imminent. During office hours call (303) 757-9228 and after office hours call the Region Public Relations contact.

- b. FHWA. If the project has Federal oversight, inform the FHWA Design/Environmental Engineer of the situation.

For additional information, see the *CDOT Guide to Hazardous Materials Response on State Highways*, and contact the CDOT Safety Officer of Office of Transportation Safety.

250.2.5.5 Hazardous Material/Hazardous Waste Consultants

The Department maintains Consultant contracts for hazardous material/hazardous waste services. The Project Engineer and the Regional Planning and Environmental Manager will determine the scope of services required and whether a Consultant is needed. If needed, the next available candidate, not having a conflict of interest, will be selected, and the Project Engineer will initiate procurement with the Center for Procurement Services. To better assess the feasibility of complete or partial avoidance of the hazardous material/hazardous waste encounter, the Department will typically request recommendations from Consultants based on risk assessment and feasibility studies of various alternatives.

250.2.5.6 Assessment of Avoidance Alternatives

Alternatives to completely or partially avoid the hazardous materials are preferred. The Project Engineer, Region Planning and Environmental Manager, and Region Resident Engineer will initially assess the feasibility of complete avoidance. As needed, CDOT Staff in the Project Development Branch will assess the feasibility of design revisions, partial deletions of work, and construction alternatives. CDOT will also consider the feasibility of terminating the Contract based on the scope of the situation, the costs of other alternatives, the anticipated magnitude of claim settlements, and the project's significance to public safety and other planned improvements. If complete avoidance is not feasible, alternatives for partial avoidance will be considered to minimize health risks. Avoidance alternatives require the Contractor's Health and Safety Officer to prepare and follow a Health and Safety Plan, as governed by Section 250 of the *Standard Specifications*.

If complete avoidance is selected, the Project Engineer will issue the Contractor a written directive addressing changes to the project and revisions to the Contract. One copy of the written directive should be forwarded to each of the following:

1. Region Resident Engineer,
2. Region Planning and Environmental Manager,
3. Region Right of Way Manager,
4. CDOT Staff Right of Way Manager,
5. CDOT Hazardous Waste Management Supervisor, and

6. other individuals as deemed appropriate.

Cost and delay issues will probably necessitate Contractor negotiations and may require a change order. It is, therefore, important to develop and maintain complete and accurate records. As needed, request a revised progress schedule from the Contractor to address the changes to the project.

250.2.5.7 Health and Safety Plan Implementation

Based on the requirements of Section 250 of the *Standard Specifications*, the Contractor's Health and Safety Officer is responsible for preparing and implementing a Health and Safety Plan to proceed with construction. The Health and Safety Plan, as well as the associated plan for site investigation, must properly reflect the requirements of Federal, State, and local regulatory agencies. Concurrence of the Chief Engineer and the FHWA Design/Environmental Engineer also may be required before work proceeds. Development and implementation will significantly involve the services of the CDOT Hazardous Material/Hazardous Waste Consultant assigned to the project. The Project Engineer will prepare and forward a written directive to the Contractor addressing specific requirements. Consider the following:

1. Site Investigation Plan. Prior to developing the Health and Safety Plan, the Contractor's Health and Safety Officer will prepare and implement a detailed work, sampling, and analysis plan to characterize and define the horizontal and vertical limits of contamination. The CDOT Hazardous Material/Hazardous Waste Consultant and the Region Planning and Environmental Manager will review this plan and recommend acceptance, revision, or rejection to the Project Engineer. Upon acceptance, the investigative work will proceed. The CDOT Hazardous Material/Hazardous Waste Consultant will oversee the work for compliance and review analytical reports prepared by the Contractor's personnel.
2. Health and Safety Plan. Based on the results of the site investigation, the Contractor's Health and Safety Officer will prepare a Health and Safety Plan to proceed with construction. The Plan will indicate the necessary training of CDOT and Contractor personnel. The CDOT Hazardous Material/Hazardous Waste Consultant will oversee implementation and report instances of non-compliance immediately to the Project Engineer.
3. Change Order. The Project Engineer is responsible for preparing the change order necessary to address the implementation of Section 250 requirements.

250.2.6 Signature Authority for Manifests

Waste manifests (i.e., chain-of-custody forms) for hazardous materials and hazardous wastes must be properly signed by authorized personnel. Ensure that a copy of the signed manifest is forwarded to the CDOT Records Center with the appropriate project number and project code.

Either the Region Planning and Environmental Manager or his staff is qualified to sign manifests. The project personnel are qualified to sign manifests if they have had proper and adequate training in the disposal of hazardous materials and hazardous waste.

CDOT CONSTRUCTION MANUAL

SECTION 300 BASES

SECTION 300 BASES

In terms of structural longevity and riding smoothness, overall pavement quality depends primarily on the quality and uniformity of the material layers constructed under the surface course. Subgrade, subbase, and base course materials must meet specified requirements and must be properly and uniformly prepared, placed and compacted to adequately support the loads of vehicular traffic. Deficiencies in subgrade, subbase, and base course construction will invariably degrade the riding surface and cause a need for premature rehabilitation.

300.1 SUBGRADE PREPARATION

Section 203 of this Manual discusses roadbed excavation and embankment construction. The resulting subgrade is the primary foundation of the total pavement structure; therefore, its construction should be closely monitored. Examine the subgrade for soft spots, ruts, and grade deficiencies. Such deficiencies must be corrected in accordance with the provisions of the Contract. Consider the following general guidelines:

1. **Low Areas.** Low areas should be filled with a suitable subgrade material, regraded, and compacted to target density. Pay particular attention to areas such as ruts. If not filled and compacted with subgrade material, ruts will invariably be filled with base material, and most compaction equipment will bridge over ruts. This bridging effect creates areas that will fail to meet specified uniform density requirements.
2. **High Areas.** Pay particular attention to rocky areas above grade. It is unacceptable practice to scalp these areas and reuse the resulting rocky material to fill low spots further ahead in station. The rocky material produced by the scalping operation will be poorly graded and will promote pavement failure. Rather, these areas should be scarified to a depth sufficient to accommodate the required compacted thickness of approved base course material.
3. **Moisture Content.** Pay particular attention to the moisture content of the subgrade material placed for compaction. Uniform compaction to target density is critical but will not be achieved if the material is either too wet or too dry.

See Section 306 and Section 307 of this Manual for additional information on subgrade reconditioning and treatment.

300.2 BASE COURSE CONSTRUCTION

The base course, or subbase if specified, is a layer of material (e.g., bituminous mix, aggregate) that is placed, graded, and compacted on top of the subgrade. Depending on the requirements of the Contract Plans, more than one layer of base course material may be required. The base

course provides the pavement structure with a free-draining, non-frost-susceptible material layer that distributes the traffic load from the surface course to the underlying subgrade. Because the base course lies directly beneath the surface course, it is critical that construction parameters be tightly controlled. Consider the following general guidelines:

1. **Material Considerations.** Check to ensure that the base course material meets the requirements of the Contract Specifications in terms of type, gradation, and uniformity. Reject substandard material based on the provisions of the Contract.
2. **Thickness.** Where applicable, lift thickness must not exceed the maximum specified for the material being placed. Verify the total compacted thickness of the base course with that specified in the typical sections of the Contract Plans.
3. **Density.** Check that the material is uniformly compacted to target density. Moisture content greatly affects material consolidation and should be monitored as required. Areas that fail to meet specified requirements must be reworked, compacted, and verified for compliance.
4. **Grade and Surface Tolerance.** To ensure a smooth riding surface and a uniform depth of surface course material, the final grade and cross-section of the base course must be within allowable tolerance. It is unacceptable to adjust the thickness of the surface course for making final adjustments to grade and cross-section.

See Section 304 of this Manual for additional information on aggregate base course construction.

SECTION 304 AGGREGATE BASE COURSE

304.1 GENERAL

Aggregate base course is a graded aggregate material that is hauled, placed, and compacted as a base course for the pavement structure. See Section 300.2 of this Manual for additional information.

304.2 INSPECTION GUIDELINES

304.2.1 Before Construction

Before construction of the aggregate base course begins, consider the following:

1. Contract Plans and Specifications. Review the Contract. Specifically note the allowable lift thickness, total required depth, and cross slope required. Check the Project Special Provisions for any changes to the Method of Measurement or Basis of Payment.
2. Material Requirements. Review the material requirements of the Contract Specifications (e.g., gradation requirements) and the related tests and acceptance criteria. Gradation requirements, in particular, may change on a project-to-project basis.
3. Scale/Weigher Certification (Tonnage Basis). Check to ensure that the commercial scale and weigher have been properly certified.
4. Load Restrictions. Review the load restrictions on public facilities. See Appendix D for applicable legal weight limits.
5. Equipment. Gather the necessary inspection equipment and be prepared to check lift thickness, total depth, and surface tolerance.
6. Spread Yield. Review the method for checking the spread yield for placed base course material. For instructions on calculating spread yields and yield factors, see the example in Appendix B for Form 282 - Asphalt Paving Inspector Daily Report.
7. Subgrade/Subbase. Ensure that the cross slope, elevation, and alignment are correct. Visually inspect the subgrade/subbase for soft spots, ruts, and grade deficiencies. Ensure that the subgrade/subbase is prepared within allowable tolerance to properly receive the required thickness of base course material. See Section 300.1 of this Manual for additional information.
8. Staking. Spot check and verify that width and thickness have been properly staked.

9. Soil Survey. In areas where the subgrade may provide an unusually stable foundation (e.g., rocky areas), consider requesting a soil survey to determine if the total thickness of the aggregate base course can be effectively reduced without compromising the integrity of the pavement structure.

304.2.2 During Construction

Consider the following guidelines when inspecting the construction of aggregate base course:

1. Load Tickets (Tonnage Basis). Do not accept any load of material without receipt of a properly completed and validated load ticket. Do not accept or sign a load ticket unless the load was actually placed as specified. Do not accept load tickets from overweight haul vehicles.
2. Material Quality. Verify that the material delivered meets specified criteria with regard to gradation requirements, and ensure that samples are tested at the required frequency. Poorly graded, oversize, and contaminated material (e.g., balls of clay) are grounds for rejection.
3. Placement. Verify the uniformity of the aggregate material. Observe the material as it is placed and spread for obvious signs of degradation (e.g., segregation, foreign material, mixing with subgrade material). Take measurements, as needed, to verify placement to the required width and depth. Check yield frequently to verify actual quantities.
4. Compaction. Observe the compaction operation for obvious signs of improper operation. Each lift must be uniformly compacted to the target density before subsequent lifts are placed. To ensure optimum density, verify the proper application of water before compaction.
5. Surface Tolerance. Check the cross-section (e.g., cross slope, thickness, elevation), as needed, to ensure that the final compacted base is within the limits of the Contract Specifications.

304.2.3 After Construction

Check that the surface is satisfactorily maintained until the next course (e.g., surface course) is ready to be placed.

SECTION 306 RECONDITIONING

306.1 GENERAL

Reconditioning is the preparation of a specified depth of the top layer of the existing subgrade. This work is generally performed by blading, watering, and compacting. The moisture content of the in situ material is critical during compaction to achieving target density.

306.2 INSPECTION GUIDELINES

306.2.1 Before Construction

Before reconditioning of subgrade material begins, consider the following:

1. Contract Plans and Specifications. Review the Contract. Specifically note the required cross-sectional elements (e.g., width, depth of thickness, cross slope). Specified surface tolerance may change on a project-to-project basis, especially where surface materials are to be placed directly on the reconditioned subgrade.
2. Equipment. Gather the necessary inspection equipment and be prepared to check depth of treatment and surface tolerance.
3. Staking. Spot check and verify that the correct lines and grades have been staked.

306.2.2 During Construction

Consider the following guidelines when inspecting the reconditioning of subgrade material:

1. Blading. Check the depth of treatment for conformance. To ensure that the proper quantity of water is being added to the subgrade material, periodically verify the moisture content with the Project Laboratory, especially in areas suspect of being too wet or too dry.
2. Compaction. Observe the compaction operation for obvious signs of failure. Visually inspect the subgrade for soft spots and other unacceptable deficiencies.
3. Surface Tolerance. Check the surface tolerance frequently for conformance to the Contract Specifications.

306.2.3 After Construction

Check that the surface is satisfactorily maintained until the next course (e.g., base course) is ready to be placed.

SECTION 307 LIME TREATED SUBGRADE

307.1 GENERAL

Hydrated lime is typically added to the in situ subgrade material to improve its stability as a foundation. The required quantities of lime and water are determined through preliminary sampling and testing of the soil. Application rates typically are specified in the Contract Plans, but may be provided by the Project Engineer. The Contract Plans also will designate the depth and width of treatment.

307.2 INSPECTION GUIDELINES

307.2.1 Before Construction

Before work on the subgrade begins, consider the following:

1. Contract Plans and Specifications. Review the Contract. Specifically note the number of courses, depth of treatment, and required cross-sectional tolerance. Check for any changes in the Method of Measurement or Basis of Payment.
2. Material Requirements. Become familiar with the material and processing requirements of the Contract Specifications (e.g., slurry mixing) and the related tests and acceptance criteria.
3. Scale/Weigher Certification. Check to ensure that the commercial scale and weigher have been properly certified.
4. Load Restrictions. Become familiar with the load restrictions on public facilities. See Appendix D for applicable legal weight limits.
5. Equipment. Gather the necessary inspection equipment and be prepared to check depth of treatment and surface tolerance.
6. Application Rate. Review the method for determining and verifying lime and water quantities and the rate of application of lime slurry for the required width and depth of treatment.
7. Hazards. Review the hazard potential and ensure that proper first aid is available to handle bodily contact with lime.

307.2.2 During Construction

Consider the following guidelines when inspecting the construction of lime-treated subgrade:

1. **Preparation.** Ensure that the subgrade has been properly prepared and that the cross-section, elevation, and alignment are correct. Visually inspect the subgrade for soft spots, ruts, and grade deficiencies. See Section 300.1 of this Manual for additional information. Where scarification is required, verify that the maximum depth of loosened material is not exceeded.
2. **Load Tickets.** Do not accept any load of material without receipt of a properly completed and validated load ticket. Do not accept or sign a load ticket unless the material was applied as specified. Do not accept load tickets from overweight haul vehicles.
3. **Material Quality.** Verify that the material delivered meets specified criteria and ensure that sampling and tests are performed at the required frequency. Reject loads based on the provisions of the Contract.
4. **Weather Limitations.** Check weather forecasts and verify that the operation is being performed within the limits of the Contract Specifications with regard to cold and inclement weather. Do not allow the operation to continue when the subgrade material is wet or frozen.
5. **Application Rate.** Check the quantities of lime and water, as needed, to verify that the proper proportions are being used. Periodically verify that the rate of application is as specified in the Contract.
6. **Mixing.** The initial mixing operation must follow immediately behind the application of the lime slurry. Check that the lime slurry, water, and scarified soil are being thoroughly mixed to the required width and depth. Residual lime, clods, lumps, and foreign matter are unacceptable. Several passes may be necessary before final mixing. Based on the results of field tests, ensure that the optimum moisture content is attained before compaction. Additional water may be required.
7. **Compaction.** Observe the compaction operation for obvious signs of improper operation. Verify that the target density is being obtained. Pay particular attention to the density obtained near edges and joints.
8. **Surface Tolerance.** Check the cross-section (e.g., cross-slope, thickness, elevation) as needed to ensure that the final compacted subgrade is within the limits of the Contract Specifications.
9. **Construction Joints.** Construction joints may be required based on the time elapsed between work on adjacent sections. Check the specific requirements of the Contract.
10. **Curing.** Check that the method of curing conforms to specified requirements. Unless an overlying seal or base course is applied, the treated subgrade is typically sprinkled with

water. Ensure that the Contractor corrects any surface damage to the final treated subgrade and that subsequent pavement courses are not prematurely placed.

307.2.3 After Construction

Check that the surface is satisfactorily maintained until the next course (e.g., base course) is ready to be placed.

CDOT CONSTRUCTION MANUAL

SECTION 400 PAVEMENTS

SECTION 400 PAVEMENTS

400.1 GENERAL

Section 400 of the Standard Specifications governs the requirements for Portland cement concrete and hot-mix asphalt (HMA) pavement construction, including rehabilitative treatments. The following Sections briefly discuss considerations that are common to these pavement construction materials.

400.1.1 Process Control/Quality Assurance Provisions

The Contractor is responsible for process control, and CDOT is responsible for quality assurance, including final acceptance of pay items under the provisions of the Contract. It is the Project Engineer's responsibility to review the appropriate specifications and provisions for the project.

It is important that CDOT and Contractor personnel clearly understand their respective responsibilities. As such, these provisions are discussed at the Pre-paving Conference and at the beginning of each major phase of the project (see Appendix A for example Pre-paving Conference Agenda). The status and results of PC/OA sampling and testing are typically discussed during routine weekly meetings. Attendees generally include: Contractor Superintendent, Quality Control/Process control Supervisor, Paving Foreman, Plant Operator, Material Supplier, Trucking Foreman, Project Engineer, Project Inspectors, and PC/OA Testers.

400.1.2 Vertical Clearance Under Structures

The Construction Manager will verify the vertical clearance of structures before, during, and after construction on any new or rehab paving project that includes work under a structure. This requires measuring the vertical clearance under bridges and overhead signs and reporting the findings to Staff Bridge Branch. See Appendix D for additional guidance.

SECTION 401 PLANT - MIX PAVEMENTS - GENERAL

Section 401 provides guidance and considerations that are common to inspecting typical CDOT plant-mix asphalt pavement projects.

401.1 PRELIMINARY CONSIDERATIONS

Before plant-mix production and paving operations begin, many factors should be considered. The following Sections briefly discuss these considerations.

401.1.1 Contract Plans and Specifications

Review the Contract, including any Special Provisions. Pay particular attention to the following:

1. type of pavement specified;
2. material specifications and mix design requirements;
3. temperature limitations (e.g., mix, mat, air);
4. number and thickness of courses;
5. construction dimensions and tolerances (e.g., widths, grades, cross-section);
6. compaction procedures and density requirements;
7. 7. sampling and testing requirements and responsibilities; and
8. acceptance and payment criteria.

401.1.2 Asphalt Paving Publications

As needed for additional guidance, review and reference the following publications during the project:

1. Hot-Mix Asphalt Paving Handbook, American Association of State Highways and Transportation Officials (AASHTO);
2. Segregation Causes and Cures for Hot-Mix Asphalt, AASHTO;
3. The Asphalt Handbook, Manual Series No. 4 (MS-4), Asphalt Institute;
4. Superpave Series No. 2 SP-2, Asphalt Institute; and

5. Special Report 180 Superpave Construction Guidelines, National Asphalt Paving Association.

401.1.3 Job - Mix Formula

The Contractor is required to submit a proposed mix design. The Regional Materials Engineer's Office will review the proposed mix design and issue a Form 43 - Job-Mix Formula when the mix design has been approved. The Form 43 will include the following information:

1. mix design number;
2. mix gradation;
3. source of materials;
4. percent of materials;
5. name of suppliers;
6. percent of reclaimed asphalt pavement materials, if selected;
7. grade of asphalt binder;
8. warm mix asphalt technology, if selected; and
9. other relevant project information.

The Project Engineer should require the Contractor to have an approved Form 43 prior to the Pre-paving Conference. Verify that copies of the reviewed and accepted Form 43 are distributed to the proper personnel. Changes affecting mix design (e.g., type and source of materials) require the Contractor to obtain a revised Form 43.

401.1.4 Longitudinal Joint and Pavement Marking Plan

The Contractor is responsible for submitting a Longitudinal Joint and Pavement Marking Plan that illustrates the location and configuration of longitudinal joints and pavement markings, including the proposed method of establishing control. Verify that the Contractor submits this Plan for review at least three days before the Pre-paving Conference. Acceptance must be provided in written form to the Contractor.

401.1.5 Pre-Paving Conference/Communications/Process Control Plan

Discuss project requirements with the Contractor at the Pre-paving Conference (see Section 400.1.1). Maintain effective communications with Contractor personnel (e.g., Superintendent, Foremen, Material Testing Supervisor, Certified Weigher). Feedback between the production

plant and the paving site is invaluable to effect needed mix adjustments in a timely manner and ensure a quality pavement.

The Contractor is responsible for submitting a Quality Control/Process control Plan to the Project Engineer for review and acceptance before the paving operation begins.

401.1.6 Weather Conditions

Review the Contract limitations with respect to cold-weather paving and inclement weather, including allowable conditions for placing prime and tack coats and underlying pavement layers and surface lifts.

401.1.7 Foundation Preparation and Conditioning

Quality, in terms of surface smoothness and durability, will be no better than that of the underlying foundation (e.g., subgrade, base, existing pavement). If the foundation is not true to grade and cross-section or is rutted, the surface course thickness will vary, and it will be difficult to obtain uniform density. This will generally result in surface undulations, dips, and swales.

401.7.1. Subgrade/Base

Verify that the subgrade and/or base have been properly graded and compacted. Check the cross-slope, elevation, and alignment for conformance. Check for soft spots and ruts, and ensure that the Contractor corrects these deficiencies. Require that any damage to the subgrade or base be repaired before paving. Do not permit paving on frozen subgrade or base material. Approve the foundation preparation and conditioning work prior to placement of the surface course.

401.7.2. Existing Pavement

On rehabilitation projects requiring an overlay, any needed pavement repair shall be completed and approved before the overlay is placed. The entire surface, including edge of pavement, also must be swept and maintained in a clean and dry condition just prior to placing and compacting the plant-mix asphalt overlay.

401.1.8 Application of Prime and Tack Coats

As specified or directed, ensure that the underlying surface is properly tacked with an approved bituminous material before the mix is placed. In addition, verify that contact surfaces such as curbs, gutters, manholes, and barriers are tacked just ahead of the paving operation. Tack and prime coat materials should not be applied beyond the limits of the final surface course. Where overspray or smearing is observed, require the affected surfaces to be cleaned. See Sections 407 and 411 for additional information.

401.1.9 Project Stationing

Verify that project stationing has been clearly marked for the purpose of documenting mix placement and yield checks. Review the method that will be used to perform yield checks. See the example for Form 282 in Appendix B for guidance on yield checks.

401.1.10 Compaction Test Section

The Contractor shall construct a test section using material that conforms to the approved Form 43 - Job-Mix Formula (see 401.1.3). The purpose of the test section is to establish the rolling pattern and sequence, including number, type, and combination of rollers, that are necessary to obtain target density. Density tests will be performed to verify compliance. The Contractor is responsible for documenting the results in a report to the Project Engineer. Before production paving begins, the Contractor shall have a Compaction Test Section Report that has been reviewed and approved by the Project Engineer. Changes to the compaction process will require a new compaction test section.

401.1.11 Mix Segregation

Mix segregation is the distribution of non-uniformly graded coarse and fine aggregate material throughout the mix. In simple terms, the aggregate material in various locations in the mat can fail to meet gradation specifications. This is a common problem with plant-mix asphalt pavements that should be closely monitored. Areas with too much coarse aggregate will be low in asphalt content and high in voids, which makes them prone to premature deterioration. Segregation can be introduced in several locations throughout the paving process (e.g., stockpiling, mixing, hauling, dumping, laydown). For example, segregation can be introduced where a windrow is not completely picked up and deposited into the paver. Suggested Best Practices for Minimizing Segregation have been summarized in the HMA Pre-paving Conference Agenda.

401.2 PRODUCTION

401.2.1 Plant Facilities

The plant must be in good mechanical condition and have adequate capacity to balance production with the laydown and compaction operations. Prior to production, consider the guidelines in the following Sections.

401.1.1. Laboratory Facilities

Verify that the Contractor has furnished the required laboratory facilities and is prepared to perform the process control sampling and testing specified in the Contract.

401.1.2. Air Quality Considerations

Verify that the Plant Operator is in receipt of a proper and current air quality certification from the governing State agency. See subsections 107.01 and 107.24 of the Standard Specifications.

401.1.3. Plant Scales

Verify scales with respect to certification, checks for accuracy and zero balance, and operation by a Certified Weigher (see subsection 109.01 of the Standard Specifications). Verify that the platform is clean, free of obstructions, and operating freely. Verify that scale tickets document the proper information. Ticket takers shall verify correct information is provided on the scale ticket as required in subsection 109.01 and shall add:

1. Placement location (station or milepost)
2. Signature of ticket taker responsible for quantities and
3. Spread data

401.1.4. Job - Mix Formula

Verify that the Plant Operator is in receipt of a properly completed and approved Form 43 - Job-Mix Formula.

401.2.2 Material Considerations

There are several factors related to material type, storage, and handling that should be considered at the plant, as discussed in the following Sections.

401.2.1. Component Materials

Prior to mix production, verify that component materials at the plant (e.g., aggregates, mineral filler, hydrated lime, bituminous material, reclaimed asphalt pavement, additives) have been properly sampled, tested, and approved for use as provided for in the Contract.

401.2.2. Aggregate Stockpiles

Aggregate stockpiles should be built in layers to minimize segregation and separated to avoid intermingling. Discourage any handling procedure that would push or dump aggregate over the side of a stockpile or otherwise degrade the material.

401.2.3. Aggregate Handling

To minimize segregation, the loader operator should work the full face of the aggregate stockpile. Dividers should be installed between cold-feed bin compartments so that aggregate piles do not overflow.

401.2.3 Mix Production and Storage

Once the plant is in operation, many factors should be monitored with respect to mix production and storage. Consider the guidelines in the following Sections.

401.3.1. Bituminous Materials

The bituminous material should be uniformly heated to the correct temperature. Localized overheating is unacceptable and should be carefully monitored. Improper handling can destroy or deteriorate the binder properties that are required by the Contract. Examples of improper handling include:

1. storing in tanks at excessive temperature,
2. storing for excessive periods of time,
3. mixing in the plant at excessive temperature, and
4. contamination by storing in tanks containing other material.

The mix discharge and delivery temperatures required in subsection 401.07 of the Standard Specifications should be verified. The Contractor should consult his binder supplier for further information on the ideal production temperatures appropriate for the grades of binder supplied to the project. In addition, verify the Contractor has a Field Binder Management Plan (see Colorado Procedure 11 in the CDOT Field Materials Manual, bullet 14).

401.3.2. Addition of Lime

Verify that lime is introduced to the aggregate as required. Verify the proportions of lime and water for conformance, and check that the pugmill uniformly combines the materials (see subsection 401.14 of the Standard Specifications).

401.3.3. Mixing Efficiency

Look for brown fines at the discharge conveyor. This is a good indication of non-uniform asphalt content caused by inefficient mixing, especially in drum-mix plants. The temperature of the dryer discharge gas, at the hood, should generally not be greater than 20 degrees higher than the aggregate temperature.

401.3.4. Mix Proportions

Verify that PC/OA samples and tests are performed as specified in subsection 106.05 of the Standard Specifications and the Field Materials Manual. Make frequent visual checks to ensure acceptability of the mix. If the aggregates are not completely and uniformly coated with bituminous material, it will result in non-uniform asphalt content.

Check for signs of segregation.

401.3.5. Mix Discharge Temperature

Check the mix temperature at plant discharge for conformance with Contract requirements. Require adjustments as needed to conform.

401.3.6. Surge Silo Storage

Temporary storage in a surge silo is acceptable, provided it does not adversely affect mix quality (e.g., binder stripping, segregation, heat loss). Pay particular attention to evidence of segregation. If the silo is improperly charged or operated, mix segregation is inevitable. The conveying device should deposit the mix into the center of the batcher at the top of the silo. The batcher gate should remain closed while charging, be fully opened when the batch is dropped, and then be quickly closed to prevent dribbling.

401.3 LOADING/HAULING OPERATION

The following Sections provide general inspection guidance.

401.3.1 Haul Trucks

The Contractor should have available an adequate number of haul trucks to provide a constant supply of mix to the paving site. Check that truck beds are tight, smooth, clean, and treated with an approved release agent before loading. Fuel oil is not an acceptable release agent.

401.3.2 Truck Loading Considerations

If trucks are not loaded properly, segregation of the mix may occur. Trucks should be laterally centered (i.e., left to right) under the discharge gate of the surge silo. Trucks should be loaded in multiple drops (e.g., first drop at the rear, second drop at the front, alternating drops in between). From three to seven drops may be necessary depending on the size of the truck (e.g., single unit, semi). The mix should not dribble from the bottom gate of the surge silo into the bed of the truck.

401.4 LAYDOWN OPERATION

Project Inspectors should focus on the following areas because poor workmanship often occurs at these locations: tapers, ramps, manholes, joints and where adverse paving conditions are encountered (e.g., cold weather, wind, rain, snow, equipment breakdowns).

401.4.1 Paving Equipment

Verify that approved and properly adjusted paving equipment is furnished and used by the Contractor. Pay particular attention to the acceptability of the receiving hopper, screed, strike-off assembly, automatic screed control, grade sensors, and sensor reference line. Verify the paver is capable of placing the mix uniformly and nonsegregated in front of the screed. Check the length of the automatic leveling ski for acceptability.

401.4.2 Mix Delivery

Once an acceptable mix has been established, note the appearance of the load (e.g., peaking or flat, dull or shiny, white or blue smoke). A differing appearance in subsequent loads may indicate an unacceptable change in mix proportions or temperature. Visually inspect the mix for signs of segregation or incomplete coating of the aggregate. The Project Inspector should notify the Construction Manager if any of the previous conditions occur.

401.4.3 Charging the Paver Hopper

When mix is dumped into the paver hopper, the truck should be aligned properly with the hopper and should not bump or jar the paver. Before the tailgate is opened, the truck operator should first raise the bed to move the material to the tailgate. Once opened, this will provide the necessary surge of mix into the hopper, which minimizes segregation. If mix is spilled on the roadway in front of the paver, ensure that it is removed before the paver moves ahead. The hopper should be kept more than half full at all times.

401.4.4 Paver Operation and Adjustment

To ensure the mix is placed properly without segregation, consider the guidelines in the following Sections.

401.4.1. Paver Control

The paver should be operated under automated controls (e.g., screed controls, grade sensors, sensor reference lines). The proper use of this automated control system is paramount to ensure a quality pavement. However, the following instances of manual operation are acceptable:

1. Irregular Areas. Manual operation of the paver is permitted in irregularly shaped and minor areas (e.g., tapers). Closely monitor these areas for conformance.

2. Automated System Failure. If the automated control system of the paver fails, the equipment may be operated manually for the remainder of the workday. Paving shall not commence if the Contractor is unable to fix the control system before the next workday.

401.4.2. Paver Speed

The operator should use the slowest paver speed that will accommodate production and delivery of the mix. The paver should be stopped and started quickly at normal operating speed to avoid gradual deceleration and acceleration. This will minimize imperfections and damage to the mat such as holes, tears, and drags.

401.4.3. Material Feed

The feed sensor and flow gates at the rear of the hopper should be adjusted so that the quantity of material moved by the slat conveyor from the hopper to the midpoint of the augers is continuous. The hopper should be kept no less than half full.

401.4.4. Paver Hopper Wings

Paver wings should be cycled at a regular interval to prevent large buildups of the material. Material retained on the wings should not be incorporated into the pavement, unless regular cycling intervals are used. The material remaining after dumping the wings at the end of the day shall be disposed of properly and not incorporated into the pavement.

401.4.5. Augers

The augers should span the full-width of the screed. The auger height should be adjusted so that the bottom of the auger is at least two inches above the finished surface of the mat.

401.4.6. Screed

The paver should be equipped with a full-width vibratory screed. A sufficient quantity of mix should be supplied by the augers to maintain a constant level of mix in front of and across the full-width of the screed. The use of drag wings is unacceptable. Verify that the screed is in proper adjustment to produce an acceptable mat.

401.4.5 Quality Considerations

The Project Inspector should consider the following guidelines:

1. Surface and Texture. The surface of the mat should be uniform in appearance and texture (without holes, tears, gouges, drags, or segregation).

2. Segregation. If segregation is observed behind the paver, immediately notify the Construction Manager and the Contractor.
3. Mat Temperature. Check the temperature of the mat behind the paver screed for conformance. Ensure the mixture is at proper temperature before rolling. The risk of thermal segregation increases when paving in cool temperatures. See Section 401.5 for additional information.
4. Subsequent Lifts. Ensure that rejected areas (e.g., segregated areas, soft spots) have been corrected prior to placing a subsequent lift.
5. Cross-Section/Thickness/Yield. Ensure that the mat is placed in conformance with the required cross-section (e.g., slope, crown) and lift thickness. Check the total thickness and yield as required. Require screed adjustments, if necessary.

401.5 COMPACTION OPERATION

The mat will be uniformly compacted using the procedures established by the compaction test section (see Section 401.1.10). Consider the guidelines in the following Sections.

401.5.1 Rolling Procedures

Document the rolling procedures used by the Contractor. Particularly note deviations from the procedures established by the compaction test section (see Section 401.1.10) and any conversations with the Contractor.

401.1.1. Rolling Sequence

In general, the compaction operation will be sequenced as follows:

1. Initial Breakdown Rolling. Initial rolling is the first pass of the rollers on the freshly placed mat just behind the paver. It is used to break down and consolidate the mix.
2. Intermediate Rolling. Intermediate rolling is the second pass of the rollers that takes place just after initial rolling. It is performed to obtain the required mat density in accordance with applicable temperature requirements.
3. Finish Rolling. Finish rolling is performed after intermediate rolling to improve the finish of the surface. It is performed while the mix is warm enough to permit the removal of roller marks.

401.1.2. Roller Speed

Rollers should, in general, not travel faster than approximately three miles per hour (brisk walking pace). A rippled surface may occur if the rollers are operated at too high a speed. The Contractor should avoid stopping rollers on the freshly placed mat.

401.1.3. Pneumatic Tire Rollers

Where pneumatic-tire rollers are used, the compactive effort is directly related to the tire pressure. Verify that the correct tire pressure is used in accordance with the compaction test section.

401.1.4. Vibratory Rollers

Vibratory rollers can be used in either the static or vibratory mode. Where the vibratory mode is used, the frequency should be as high as practical without detriment to the mat.

Consider the following guidelines:

1. **Static Mode.** Static mode, or non-vibratory rollers, should be used on mats that are less than 1.25 inches thick. The vibratory mode should not be used during finish rolling of surface courses or on waterproofed bridge decks.
2. **Low Amplitude.** A low-amplitude vibratory mode should be used for mat thicknesses between 1.25 and three inches.
3. **High Amplitude.** A high-amplitude vibratory mode should be used for mats greater than three inches thick.

401.1.5. Manual Compaction Methods

Hand-operated mechanical tampers should be used in areas that are inaccessible to rollers.

401.5.2 Temperature Considerations

Temperature plays a critical role in the compaction of plant-mix asphalt pavements and should be closely monitored. See subsection 401.07 of the Standard Specifications.

401.5.3 Joint Construction

The quality of longitudinal and transverse joints will affect the quality and long-term performance of the asphalt pavement. The surface must be smooth across the joints after density is obtained. See Section 401.1.4 for additional information. The following Sections provide additional guidance.

401.3.1. Traverse Joints

When transverse joints are required, see subsection 401.18 of the Standard Specifications.

401.3.2. Longitudinal Joints

When longitudinal joints are required, see subsection 401.16 of the Standard Specifications. Refer to Colorado Procedure 11 in the CDOT Field Materials Manual, bullet 14.

401.5.4 Safety Edge

The paver shall include an approved longitudinal wedge system to create a sloped safety edge as shown on the plans.

401.6 SMOOTHNESS

Consider the following guidelines:

1. Contractor PC/OA Smoothness Profiling. The contractor shall perform the following PC operations for smoothness profiling:
 - a. Profiler. The contractor will perform PC profiling on the first 2000 tons of the final layer or each day's paving within 24 hours after the concrete has achieved sufficient strength for PCCP. The Contractor shall not perform the PC testing until after the concrete has attained a compressive strength of 1,000 psi if a light weight profiler is used or 2,000 psi if a high speed profiler is used. The profiler is operated by Contractor staff; this profiling does not have to be in the presence of a CDOT inspector. Only CDOT certified profiling equipment may be used for CDOT projects. The contractor's staff must be properly trained and have a current CDOT Operator's certification. A list of certified profilers and operators can be found on the CDOT website at

<https://www.codot.gov/business/designsupport/matgeo/pave-smooth-testing>

Prior to PC profiling the contractor shall submit a traffic control plan for approval.

Profile results from the PC smoothness profiling must be submitted to the Engineer within 48 hours after profiling. The profile results shall show the Mean Roughness Index (MRI) for each 0.1 mile section. Paving should be suspended when profile results show corrective work is required. Paving will remain suspended until the contractor proposes corrective actions in writing to the Engineer.

- b. Straightedge. A 10-foot straight edge is supplied by the contractor. The straightedge method performed by the Contractor will be employed in areas not requiring profiling by the profiler or areas that could not be profiled by the profiler. Observe the operation, document deviations greater than 3/16 of an inch.
2. Initial Smoothness Acceptance Profiling. The Contractor's High-Speed Profiler will be used for acceptance of the pavement. This profiling is performed to set the incentive for each 0.1-mile section and to designate areas requiring corrective work. To prepare for the profiling the contractor shall perform the following:
 - a. Submit a traffic control plan that will allow the continuous collection of data for a lane. The traffic control plan shall allow the profiler to run the length of the lane at a constant speed without stopping. Profile testing shall not be performed without traffic control using the approved MHT.
 - b. The contractor shall mark the paving limits and each excluded area. These marks need to be verified by the CDOT inspector.
 - c. The contractor shall lay out a distance calibration site. This site may be outside the project limits, but must be checked by the inspector.
 - d. The lanes must be in their final configuration and allow the profiler to profile in the intended direction of traffic.
 - e. The lanes shall be free of debris and construction activity while profiling.
 - f. This profiling cannot occur when the pavement is wet or icy. The ambient temperature shall be at least 34° F for the profiler to operate.

When the contractor is ready for acceptance, he must submit a request at least 10 days prior to profiling. The contractor will also notify the Staff Materials and Geotechnical Branch's Concrete Unit. The Staff Materials and Geotechnical Branch's Concrete Unit may verify the Contractor's profile results. Verification will occur at the same time that the contractor profiles the pavement. This testing should be witnessed by the CDOT inspector in CDOT is not performing verification testing.

After the profiling, the contractor shall submit the electronic data to the Project Engineer. The Project Engineer will submit the electronic data to the Staff Materials and Geotechnical Branch's Concrete Unit at DOT_Profiles@state.co.us. The data shall be submitted as soon as possible so that the contractor's profiling may be verified within the allowable amount of time. The Staff Materials and Geotechnical Branch's Concrete Unit may verify the Contractor's profile results and will notify the Project Engineer of its intent to verify the data. The contractor shall not perform any corrective work until after the verification profiling has occurred. The Project

Engineer may call the Staff Materials and Geotechnical Branch's Concrete Unit prior to QA profiling to ask if the contractor needs to be verified. The verification profiling can take place at the same time as the contractor's QA profiling to save on traffic control.

A report for each lane will be sent to the Project Engineer showing the HRI MRI for each 0.1-mile section, the incentive/disincentive for each 0.1-mile section and areas requiring corrective work. If the contractor performed any corrective work prior to this initial smoothness profiling, the engineer shall reduce the incentive for any 0.1-mile section where the contractor performed corrective work to \$0.00 even if it was a short distance of grinding. The disincentive will not be changed.

Corrective Work. The contractor will perform the indicated corrective work. Once the corrective work is completed, recheck the acceptability of the corrected final surface with respect to texture and skid resistance. Joint sealant and pavement markings damaged by grinding shall be removed and replaced.

1. Final Smoothness Acceptance Profiling. The Contractor's Profiler will be used for acceptance of the pavement. This profiling is used to check that the contractor performed and fixed all areas of corrective work. The profiling and contractor's responsibilities are the same as the initial smoothness profiling.

After the profiling, a report for each lane will be sent to the project showing the HRI MRI for each 0.1-mile section, the revised incentive/disincentive for each 0.1-mile section and areas requiring corrective work. Each 0.1-mile section showing an initial disincentive can have that disincentive reduced or eliminated, but that section cannot earn incentive.

If corrective work is still indicated, the contractor shall perform the corrective work and the lane will be re-profiled. For every re-profile after the first Final Smoothness Acceptance Profiling, the contractor will be charged \$500.

Verification profiling may occur on any profiling done by the contractor.

SECTION 402 RESERVED

SECTION 403 HOT - MIX ASPHALT

403.1 GENERAL

The Contract Plans will designate the type and extent of base preparation, the number and thickness of mix courses required, and the lines, grade, and cross-section required for the final HMA surface. Use the guidelines presented in Section 401.

403.2 WARM MIX ASPHALT

Warm mix technology is an additive that the contractor may elect to use.

Foaming is another warm mix technology where the asphalt producer injects water into the mix, through a special nozzle. Currently this technology is only approved for up to 10,000 tons per project, until performance data is submitted and analyzed. This method is less costly than the chemical additive used in the first warm mix asphalt method, as the only additive is water.

When either method of warm mix asphalt is used, it is treated the same as conventional hot mix asphalt, both in the field and in the laboratory, with respect to compaction and testing. The only difference is the contractor is able to obtain proper compaction at lower temperatures, thus being able to extend haul distances.

SECTION 404 RESERVED

SECTION 405 HEATING AND SCARIFYING TREATMENT

405.1 GENERAL

Heating and scarifying treatment is a rehabilitative process typically specified to recycle the uppermost layer of an existing asphalt pavement in preparation for a new asphalt overlay.

405.2 INSPECTION GUIDELINES

405.2.1 Before Construction

Before the heating and scarifying operation begins, consider the following guidelines:

1. **Contract Plans and Specifications.** Pay particular attention to the requirements for the rejuvenating agent.
2. **Surface Preparation.** Verify that the surface is properly prepared before the operation begins. The surface should be cleaned of all loose and foreign debris by using either mechanical or hand methods. Items such as manholes also should be clearly marked.
3. **Equipment.** Verify that the Contractor has available the proper type and number of equipment for the operation. Verify that the heating and scarifying, paving, and rolling equipment conforms to specified requirements. Pay particular attention to the acceptability of the type and number of steel-wheel and pneumatic-tire rollers provided.
4. **Flammable Materials.** Inform the State Patrol or local law enforcement agency of project scope and limits. Additional signing may be required.

405.2.2 During Construction

Consider the following guidelines during the heating and scarifying operation:

1. **Width of Heating.** Verify that the width of heating beyond that of scarification meets minimum specified requirements.
2. **Width and Depth of Scarification.** Check the width and depth of scarification for conformance. Verify that the Contractor maintains adequate control over the scarification depth and that testing is performed as required.
3. **Overlap of Adjacent Passes.** Adjacent passes of the heating and scarifying operation should overlap. Verify that the overlap of adjacent passes extends into the previously placed mat to the minimum specified requirements.

4. Temperature. Check the temperature of the scarified material for conformance. See subsection 405.03 of the Standard Specifications.
5. Rejuvenating Agent. Check the conformance of the rejuvenating agent applied to the scarified material. The agent must be applied while the scarified material is hot and before it is transferred to the paving machine.
6. Distribution of Material. After the hot recycled material is transferred to the paving machine, the mix will be distributed (i.e., screeded) to the cross-section designated on the Contract Plans. Verify the width, depth, and cross-slope for conformance.
7. Compaction. Immediately behind the paver, the rolling operation should begin. Check that the type and number of rollers and the rolling pattern employed meet the requirements for breakdown and finish rolling. Pay particular attention to the temperature of the material at the time of compaction, and verify that the required density is being obtained.

405.2.3 After Construction

Review the work to ensure acceptability, and discuss with the Contractor any unacceptable areas. Enforce the Contract provisions with respect to needed corrections. Do not allow the Contractor to place a subsequent asphalt overlay over the treated surface before the minimum specified elapsed time.

SECTION 406 COLD ASPHALT PAVEMENT (RECYCLE)

406.1 GENERAL

Cold asphalt pavement recycling is typically specified as a rehabilitative treatment for asphalt pavements. The work generally consists of pulverizing (e.g., milling) the existing asphalt surface within the limits and to the depth required by the Contract, mixing a recycling agent with the pulverized material, and then spreading and compacting the recycled material to the specified grade, cross-section, and density.

406.2 INSPECTION GUIDELINES

406.2.1 Before Construction

Before the cold asphalt pavement recycling operation begins, consider the following guidelines:

1. Contract Plans and Specifications. Pay particular attention to the requirements for the pulverized material, recycling agent, temperature requirements, and sealing emulsion.
2. Surface Preparation. Items such as manholes should be clearly marked.
3. Recycling Equipment. Check the operation of the recycling equipment for conformance with respect to its pulverizing capabilities, control over width and longitudinal joint offset, automatic depth control, screening and crushing capabilities, continuous measurement of recycled material and automatic metering of recycling agent, and mixing and windrow placement capabilities.
4. Paving Equipment. Check the paving equipment for conformance. Verify the proper operation and adjustment of the pick-up machine, paver, and screed. The screed does not have to be heated.
5. Compaction Equipment. Check the compaction equipment for conformance. Both pneumatic-tire and steel-wheel rollers, either static or vibratory, will be required. The use of the vibratory mode for finishing requires previous approval.
6. Representative. Verify that a representative of the manufacturer of the recycling agent is present at the beginning of the operation and remains on site to provide guidance until acceptable production has been established.

406.2.2 During Construction

During the cold asphalt pavement recycling operation, consider the following guidelines:

1. Depth of Milling. Verify that the underlying material is not disturbed beyond the depth of milling designated on the Contract Plans.
2. Longitudinal Overlap. Verify that the overlap of adjacent passes meets specified minimum requirements.
3. End Overlap. Where the operation is halted, check that the operation is restarted by overlapping the end where the operation stopped.
4. Vertical Faces. Verify that the faces of vertical cuts in the pavement are properly cleaned during the operation and are not left overnight.
5. Mixing Operation. The recycling agent will be automatically metered based on the continuous weight measurement of pulverized material. Verify that the rate of application is calibrated to within allowable tolerance. Water may be added to the pulverized material to facilitate mixing uniformity.
6. Spreading Mix. Verify that the production of recycled material is balanced with paving for a continuous operation. Check that the mix is uniformly placed in windrows to prevent segregation. The paving equipment should pick up the entire windrow and place the recycled material in one pass to the required grade and cross-section.
7. Segregation Considerations. Watch for segregation in the windrows and the screeded surface, and enforce the provisions of the Contract with respect to removal and replacement of unacceptable mix. If segregation is evident, suspend the operation until the problem can be identified and corrected.
8. Compaction Operation. Pneumatic-tire rollers shall be used for initial breakdown and compaction rolling. Compaction should generally stop where no further displacement is observed. Hand methods will be necessary for areas inaccessible to rollers. Finish rolling will be performed with steel-wheel rollers using either the static or vibratory mode. Note, however, that the use of the vibratory mode requires previous approval and low amplitude. Verify that the required density is obtained and that the surface finish is free of roller marks and damage. Where cracks, movement, or pavement distress is observed, suspend the operation until the problem can be identified and resolved. Enforce the Contract provisions with respect to removal and replacement of deficient areas. See subsection 406.07 of the Standard Specifications.
9. Longitudinal Joints. Verify that longitudinal joints are laterally offset between layers at the specified minimum distance but do not fall in wheel paths.
10. Free Moisture Tests. Check that free moisture tests are being performed as required, and enforce the specified limits of free moisture before allowing placement of a designated sealing emulsion or asphalt overlay. Enforce the Contract provisions with

respect to removal and replacement of damaged and soft areas before any sealing emulsion or asphalt overlay is placed. See subsection 406.07 of the Standard Specifications.

406.2.3 After Construction

Review the work to ensure acceptability, and discuss with the Contractor any unacceptable areas. Enforce the Contract provisions with respect to needed corrections and minimum time before opening the section to any traffic after compaction. A sealing emulsion may be specified to minimize surface raveling. Where applicable, verify the limits of treatment and rate of application for conformance. Where an asphalt overlay is designated, verify that the minimum overlay thickness is placed over the recycled pavement within the minimum specified time limit. Check the density, grade, and crosssection of the final surface for conformance.

SECTION 407 PRIME COAT, TACK COAT, AND REJUVENATING AGENT

407.1 GENERAL

Where prime or tack coat is specified, the Contractor will be responsible for preparing and treating the surface with a bituminous material within the limits designated on the Contract Plans. Prime coat is typically applied to a base or foundation course to provide a dust-free surface that promotes adhesion between the underlying surface and the overlying asphalt mix. The tack coat promotes bonding between the new and old materials. The rate of application should be carefully monitored. Too much tack coat promotes slippage between the two layers, rather than adhesion, and the excess material generally bleeds to the surface along construction joints. If tack coat is applied too far ahead of the paving operation, the material will usually collect a film of dust, which also causes poor adhesion.

407.2 INSPECTION GUIDELINES

407.2.1 Before Construction

Before prime or tack coat is applied, consider the following guidelines:

1. **Contract Plans and Specifications.** Pay particular attention to the type and grade of bituminous material specified and its application rate and temperature requirements.
2. **Distribution Equipment.** Verify that the distribution unit meets specified requirements with respect to material heating, circulation, and application control. Before the operation, verify that the application rate and the spray width have been properly set and that the distributor is capable of positively cutting off the flow of material.
3. **Material Considerations.** Retain and check the Certificates of Compliance and delivery tickets to ensure that the type and grade of bituminous material conform to specified requirements.
4. **Surface Preparation.** Verify that the surface to be treated has been properly prepared. The base must not be too dry, because this will cause the prime coat material to ball up. Before tack coat is applied, ensure that the existing surface has been properly repaired, patched, and swept. Vertical edges, such as curbs and manholes, must also be clean. Otherwise, the tack will not adhere to the surface.

407.2.2 During Construction

Consider the following guidelines during the application of prime and tack coats:

1. **Application Rate.** The application must be uniform and continuous at the specified rate. Verify that spray bar nozzles deliver without streaking. Skipped or deficient areas must be corrected. Excess material (e.g., overlaps, puddling) also must be corrected (e.g., squeegee, blotter material). In general, no more material than that needed for the day's operation should be applied. Overspray and smearing of curbs, gutters, and barriers is unacceptable and should be corrected. Consult the Project Engineer if penetration appears to be an issue.
2. **Blotter Material.** Where traffic must be maintained on the treated lane and the material does not adequately penetrate the surface, blotter material must be spread to absorb the excess bituminous material.
3. **Traffic.** Check for proper handling of traffic to prevent pickup, tracking, and contamination of the bituminous material. Traffic should generally be kept off the material as long as practical. Where traffic must be maintained on the facility, not more than one-half the width of the section should be treated in the same pass.

SECTION 408 JOINT AND CRACK SEALANT

408.1 GENERAL

Joint and crack sealing is a routine method of pavement rehabilitation. Joints and cracks in the pavement surface that are not properly sealed will allow water to infiltrate into the underlying layers of the pavement structure causing premature deterioration. Where joint and crack sealing is specified, the Contractor will be responsible for cleaning and preparing joints and cracks and furnishing and placing sealant material.

408.2 INSPECTION GUIDELINES

408.2.1 Before Construction

Consider the following guidelines before the joint and crack sealing operation begins:

1. **Contract Plans and Specifications.** Pay particular attention to the material requirements for the hot poured joint and crack sealant material.
2. **Material.** The Contractor shall supply approved sealant material and under no circumstance should different materials be mixed during the operation. The Materials and Geotechnical Branch pretests all batches of crack sealant. Contact the Bituminous Unit of the Asphalt Pavement Program (303) 398-6530 for approved crack sealant.
3. **Equipment.** Verify that the Contractor has adequate equipment to properly heat and pour the sealant material in a continuous operation.
4. **Material Preparation.** Check to ensure that the Contractor prepares the sealant material according to the manufacturer's recommendations.

408.2.2 During Construction

During the joint and crack sealing operation, consider the following guidelines:

1. **Crack Width.** The Contractor should be sealing cracks between 0.125 and one inch in width.
2. **Joint and Crack Preparation.** Prior to sealing, verify that joints and cracks are properly cleaned of loose and foreign material to the specified depth. This operation is generally performed with hot compressed air. Immediately prior to sealing, the vertical faces of the joint or crack should be clean, dry, and warm. This promotes a positive bond of the sealant material to the vertical faces.

3. Sealant Temperature. Periodically verify the sealant temperature for conformance. Overheating degrades the material and should not be permitted.
4. Sealing Operation. Verify that the sealant is poured in the crack or joint reservoir to a height flush with the pavement surface. Excess sealant material must not remain on the surface but should be squeegeed to the specified width on either side of the crack or joint.

408.2.3 After Construction

Before opening to traffic, the sealant material should be allowed to cure sufficiently to prevent being picked up or pulled out of the crack or joint by traffic. If this becomes a problem, require blotter material to be applied to the sealant material. Enforce the Contract provisions with respect to removal and replacement of damaged seals.

SECTION 409 CHIP SEAL

409.1 GENERAL

Seal coats are typically specified to lengthen the service life of an existing pavement and to improve the skid resistance of the surface. Prior to chip seal, it is important that the surface be properly prepared. The bituminous and aggregate cover materials must not be placed prior to the Project Engineer's approval of the prepared surface. The Contract Plans will designate the limits of treatment. Where the bituminous material is to be used as a fog seal, aggregate cover generally will not be specified.

409.2 INSPECTION GUIDELINES

409.2.1 Before Construction

Before the seal coat operation, consider the following guidelines:

1. Contract Plans and Specifications. Pay particular attention to the type, grade, and temperature requirements of the bituminous material, the gradation requirements of the aggregate cover material, and their respective rates of application.
2. Equipment. Check equipment for conformance. The Contractor should provide adequate bituminous distributors, aggregate spreaders, pneumatic-tire rollers, and rotary power brooms for a continuous operation. Pay particular attention to the distributor. It should have adequate means for controlling and monitoring the temperature, rate, and width of application of bituminous material.
3. Test Section. A test section will be used, as needed, to evaluate the application rates, yield, and penetration. Embedment of approximately 75 percent of aggregate into the bituminous material is recommended. The operation should consistently use either butt or lap seams, but no seams should be placed in the wheel paths of operating traffic. The sequence of placement should minimize turning movements on the freshly placed surface.
4. Maintenance of Traffic. Verify that the correct types of temporary pavement markings and signing have been properly placed.
5. Surface Preparation. Prior to sealing, verify that the surface has been properly prepared and approved. The surface should be to the desired line and grade, free of irregularities, clean, and dry. Power brooms are generally used to remove loose and foreign material. Items such as manhole covers, drop inlets, valve boxes, and valley pans should be covered with dirt or paper to prevent bonding with the bituminous material.

409.2.2 During Construction

409.2.2.1 Application of Bituminous Material

During the application of the bituminous material, the Project Inspector should ensure conformance with respect to the type, grade, temperature, and application rate of the material within the limits designated on the Contract Plans. Consider the following guidelines:

1. **Temperature/Initial Quantity.** Check the temperature of the material in the distribution truck for conformance. Determine the initial quantity of material in the distribution truck before it is applied.
2. **Distribution Bar/Nozzles.** Check that the distribution bar applies at a uniform, continuous spread. End nozzles should be normal to the surface (i.e., turned at 90 degrees) to reduce overspray on curbs and reduce development of false seams. Adequate bituminous material should be applied along the seam line, not just oversprayed. The Contractor should have spare nozzles readily available.
3. **Application Uniformity.** Check to ensure that the bituminous material is applied at the specified rate uniformly over the surface in a continuous operation without producing deficient areas or areas of excess material. Check the yield as required for confirmation. Particularly watch for streaking. Halt the operation if streaking is observed and require corrective action. Junctions of adjacent passes should be closely monitored. Areas with too little or too much bituminous material must be corrected before application of the cover aggregate. In addition, the application rate should be adjusted to compensate for oxidized and open-graded surfaces. Contact the Project Engineer where such areas become problems.
4. **Overspray.** Check that the bituminous material is not oversprayed on adjacent items such as curbs and sidewalks. If observed, require the Contractor to thoroughly clean such excess.
5. **End Overlaps.** Pay particular attention to the start and cut-off operation of the distribution truck. The truck should be moving forward in the direction of application when the spray bar is opened or closed. Verify that building paper is used at the beginning and end of each spread. Such practice minimizes excess from overspray and dripping and helps to square the ends of application.
6. **Length of Application.** The length of application of the bituminous material should be balanced with the aggregate spreader. In general, the spreader should be maintained relatively close behind the distribution truck. Otherwise, the bituminous material may begin to cool sufficiently to prevent the aggregate from being embedded and held in place by the bituminous material when rolled.

7. Fog Seal. Where fog seal is specified, verify that the bituminous material is applied at the specified rate. Aggregate cover will generally not be required where fog seal is specified.

409.2.2.2 Application of Aggregate Cover

During the application of aggregate cover material, the Project Inspector should ensure conformance with respect to the type, gradation, and application rate of the material within the limits designated on the Contract Plans. Consider the following guidelines:

1. Material and Quantity. Check that the type and gradation of the aggregate material conforms to specified requirements. Record the quantity of aggregate delivered and spread (i.e., volume or weight from delivery ticket).
2. Dust Considerations. The cover material shall be moistened with water prior to placement to reduce dust emission. This also reduces the dust coating on the aggregate, which enhances bonding with the bituminous material.
3. Timing of Operation. The aggregate spreader should be following relatively closely behind the application of the bituminous material. Do not allow the aggregate to be placed on bituminous material that has been allowed to chill, set, or dry.
4. Width of Application. Check to ensure that the aggregate cover is placed within the limits of the bituminous material previously applied to the surface.
5. Application Rate/Yield. Ensure adequate coverage and verify the application rate and yield for conformance. Deficient areas must be adequately covered with additional aggregate, and excess piles must be trimmed prior to rolling.
6. Haul Truck Considerations. Verify that the equipment tires do not roll over and damage the freshly applied and uncovered bituminous material. Also check that equipment tires do not pick up the aggregate material. Enforce the Contract provisions with respect to needed repairs. To help embed the aggregate into the bituminous material, haul trucks should stagger their wheel paths.

409.2.2.3 Rolling Operation

After the aggregate has been spread, the rolling operation should begin immediately behind the spreader to embed the aggregate into the bituminous material. Consider the following guidelines:

1. Roller Tires. The correct pressure should be used in the tires of the pneumatic tire rollers. Pay particular attention to the operation to ensure that the aggregate is not picked up by the tires.

2. **Rolling Operation.** To properly embed the aggregate, pneumatic-tire rollers should perform three complete passes over the aggregate prior to the bituminous material taking its initial set. Verify that the rolling operation is keeping up with the aggregate spreader; otherwise, it will be difficult to embed the aggregate into the bituminous material. Verify that areas of exposed bituminous or loose aggregate are not left at the end of the day. In addition, rapid start and stop movements should be avoided to minimize damage to the treated surface.
3. **Coverage.** Check the surface behind the rolling operation to ensure that adequate coverage of aggregate remains over the bituminous material. Require correction of areas identified with deficient or excess aggregate material.
4. **Embedment.** Check the acceptability of embedment of the aggregate in the bituminous material. Embedment of approximately 75 percent of aggregate into the bituminous material is recommended. In addition, check for proper bonding of the two materials. If weak bonding is evident after the bituminous material takes its initial set, notify the Contractor of the deficient area.
5. **Bleeding.** Blotting sand should be used in areas where excess bituminous material bleeding occurs.

409.2.2.4 Brooming Operation

After the rolling operation has embedded the aggregate into the bituminous material and set sufficiently to hold bond, the brooming operation should begin. Brooming is performed to remove loose aggregate and chips that did not bond with the bituminous material. The operation is generally performed at the beginning of the next work day. Ensure that the operation does not remove embedded aggregate. In such cases, lighter brooming or a delay in the operation may be needed.

409.2.3 After Construction

After the brooming operation, verify the acceptability of the final surface with respect to proper coverage, embedment, and bonding of the aggregate with the bituminous material. Enforce the Contract provisions for any needed surface corrections. Verify the correct installation of traffic control devices (e.g., temporary paving markings, drums) prior to opening the section to traffic.

SECTION 410 RESERVED

SECTION 411 ASPHALT MATERIALS

411.1 GENERAL

Various types of bituminous materials may be specified in the Contract, and the type specified will depend on its intended application (e.g., prime, tack, seal coat).

411.2 INSPECTION GUIDELINES

411.2.1 Before Construction

Before the Contractor applies the bituminous material, consider the following:

1. Contract Plans and Specifications. Pay particular attention to the type and grade of bituminous material specified and any dilution or additive requirements.
2. Storage. Depending on the project, several different types of bituminous material may be necessary for different operations. Check to ensure that the Contractor properly stores different types of bituminous material separately without mixing. Verify the Contractor has a Field Binder Management Plan (see Colorado Procedure 11 in the CDOT Field Materials Manual).

411.2.2 During Construction

Check to ensure that the Contractor's application operation does not result in overspray on adjacent items such as curbs, gutters, sidewalks, and structures. Enforce the Contract provisions with respect to cleaning such marred areas.

411.2.3 After Construction

In general, it is best not to close the facility to traffic, even if this means maintaining a one-way operation. In such cases, verify that the bituminous material is not oversprayed into the adjacent lane. To avoid damage from traffic, do not open the facility to traffic until the bituminous treatment has sufficiently cured.

SECTION 412 PORTLAND CEMENT CONCRETE PAVEMENT

412.1 PRELIMINARY CONSIDERATIONS

The construction of Portland cement concrete pavement is a highly mechanized operation that requires the inspection of a vast quantity of material and a working knowledge of numerous types of equipment. Project Inspectors that are assigned to the work should be thoroughly familiar with the Contract Plans and Specifications, Special Provisions, construction methods and details, and the sequence of operations.

412.1.1 Contract Plans and Specifications

Pay particular attention to the class of concrete required, component material specifications, mix design requirements, consistency requirements for the proposed method of operation, and the requirements for reinforcement, dowel bars, tie bars, joint sealant, and curing materials. Become familiar with the proposed method and sequence of operation with respect to mix production, mix hauling, joint construction, reinforcement and concrete placement (i.e., fixed form, slip form), finishing, curing, joint sawing, profiling, surface tolerance, and slab and surface correction requirements.

412.1.2 Portland Cement Concrete Mix Design

Before mix production and paving begins, the Project Engineer and Project Inspector should understand the mixing and batching procedures, and be able to verify that the Portland cement concrete mix design has been approved for use on the project.

412.1.3 Process Control Plan

Verify that the Contractor's Process Control Plan has been submitted and approved. The Process Control Plan will document the Contractor's proposed sampling and testing procedures for quality control process control of pavement thickness. It shall address the sampling and testing method and frequency for traffic lanes, shoulders, intersections, entrances, and crossovers. Use the Process Control Plan to verify conformance of quality control process control by the Contractor.

412.1.4 Pre-paving Conference/Communications

Discuss project requirements and sequence of operations with the Contractor at the Prepaving Conference (see Section 400.1.1). Establish and maintain communications with Contractor personnel (e.g., Superintendent, Foremen, Material Testing Supervisor, Certified Weigher). During the paving operation, communication between the plant and the paving site is invaluable to effect needed adjustments to the mix and ensure quality.

412.1.5 Equipment Considerations

Verify the acceptability of the number and type of equipment supplied by the Contractor.

Consider the following:

1. Hauling/Placing Equipment. Check the acceptability of haul trucks, spreading, strike-off, consolidation, and finishing equipment for the particular method of paving used (i.e., fixed-form or slip-form paving).
2. Load Transfer Devices/Bars. Check the location and operation of equipment used to place load transfer devices and bars.
3. Vibrators. Check vibrators for conformance with respect to specified type, diameter and spacing. Frequency of vibrators should be tested and documented.
4. Test Bridge. Verify the acceptability of the test bridge provided for CDOT personnel.
5. Safety Edge. The Contractor shall use an approved longitudinal paver wedge system to create a sloped safety edge.
6. Joint Sawing Equipment. Check that extra saws, blades, and lighting equipment have been provided to continue joint sawing sufficiently to control cracking.
7. Curing Equipment. Verify that standby equipment has been provided for the curing operation in the event of a mechanical breakdown.
8. Texturing Equipment. Check the acceptability of the equipment needed for surface texturing.
9. Concrete Protection. Check that the Contractor has available the tools and materials necessary to protect the concrete from cold and wet weather damage.
10. Profiler. Check that the high speed profiler has been calibrated as specified.

412.1.6 Utilities

Verify that the manholes, inlets, and utilities that will be incorporated into the pavement are properly located and marked.

412.1.7 Subgrade/Base Preparation

Check that the subgrade/base has been constructed to the required grade and crosssection and compacted to the required density. Ensure that high or low spots and soft or muddy spots have been properly corrected. The final grade must be in a smooth and non-frozen condition. Where

the prepared grade is untreated, verify that the material is maintained in a moist condition just ahead of the paver without forming mud or pools of water. Intermittent sprinkling may be required.

412.1.7.1 Fixed-form Considerations

For fixed-form paving operations, consider the following guidelines:

1. Rail Forms. Verify rail forms for conformance with respect to dimensions and condition. Rails should be clean and in good repair. Reject damaged forms.
2. Limits of Trimming. Check the limits of trimming beyond the width of the forms. This area will be used as a track path for finishing, curing, and surface texturing equipment.
3. Foundation. Verify that the rail foundation is uniform and properly compacted. The foundation must support the operation so that the top face of the rails remains flush with the final pavement surface without moving.
4. Rail Movement. Verify rails are secured with stakes and locked pins. Check for movement in any direction. Visible springing or settlement is unacceptable.
5. Oiling. Ensure that the forms are thoroughly cleaned and coated with oil or other approved release agents.
6. Resetting/Removal. Require resetting of unacceptable forms. The forms should not be removed until the concrete has set sufficiently to hold the edge of the slab.

412.1.7.2 Slip-form Considerations

For slip-form paving operations, the Contractor shall adjust the automatic alignment and elevation controls to spread, consolidate, screed, and finish the concrete in a single pass.

412.2 REINFORCEMENT AND JOINT CONSIDERATIONS

There are many factors that the Project Inspector should consider with respect to the provisions for reinforcement and joint construction. Consider the guidelines in the following Sections.

412.2.1 Reinforcing Steel

Where reinforcing steel is specified, check the reinforcement for conformance with respect to material type and condition. Verify that the Contractor properly stores the reinforcing steel without damage or degradation. Pay particular attention to the storage and handling of epoxy coated bars. Require repair or replacement of the epoxy coated material, as needed. Verify the acceptability of the placement operation. The Contractor shall supply and use a MIT-Scan-2.

Check the method of securing bars and the depth and location of placement. Observe the consolidation operation for evidence of unacceptable bar movement. Vibrators must not come into contact with reinforcement.

412.2.2 Construction Joints

Use the following guidelines to inspect longitudinal and transverse construction joints:

1. Longitudinal Construction Joints. Where longitudinal construction joints are built, check the following for conformance:
 - a. Location. Check that longitudinal construction joints are properly located, especially with respect to lane lines.
 - b. Keyways. Verify the correct installation of keyways. It is preferable to construct female keyways.
 - c. Tie Bars. Where tie bars are specified, verify the diameter and length of the epoxy coated bars for conformance. Observe the insertion operation for proper location and spacing of bars. Ensure that the Contractor demonstrates, by testing, the required pullout resistance where tie bars are stabbed or drilled and epoxied into place.
2. Transverse Construction Joints. Verify that transverse construction joints are properly located and constructed. Check to ensure the location of joints for conformance with minimum spacing requirements.

412.2.3 Weakened Plane Joints

Use the following guidelines to inspect longitudinal and transverse weakened plane joints:

1. Longitudinal Weakened Plane Joints. Where longitudinal weakened plane joints are constructed, check the following for conformance:
 - a. Location. Check that longitudinal weakened plane joints are properly located, especially with respect to lane lines.
 - b. Tie Bars. Where tie bars are specified, verify the diameter and length of the epoxy coated bars. Check that the bars are inserted by an approved method ahead of the vibration operation. Observe the insertion operation for proper location, depth, and spacing of bars.
 - c. Sawing. Check the dimensions of saw cuts. Ensure that the sawing is completed at the proper time to prevent random cracking and raveling.

2. Transverse Weakened Plane Joints. Where transverse weakened plane joints are constructed, check the following for conformance:
 - a. Location. Check that transverse weakened plane joints are located as designated on the Contract Plans.
 - b. Load Transfer Devices. Verify that dowels conform to the specified type, diameter, and length of material. Check to ensure that the number and size of shipping braces does not exceed what is specified in subsection 412.13(b)2 of the Standard Specifications. Check to ensure that the horizontal support wires and shipping braces are not cut prior to concrete placement and that the assembly is firmly secured to the subbase as required. Check welding to ensure that only one end is welded. Check the tolerance of placement for acceptability with respect to location, depth, and spacing. Ensure that the Contractor marks the center of the dowel assembly on both sides of the slab for reference by the saw crew. Verify dowel lubrication for conformance. Ensure that joints in widening and shoulders align with those in the adjacent slab.

The Project Inspector should do quality assurance to ensure the location of the dowels in the plastic pavement behind the paver.

- c. Sawing. Check the dimensions of the saw cuts for conformance. Ensure that the sawing is completed at the proper time to prevent random cracking and raveling. If uncontrolled cracking is observed, verify that the Contractor moves the sawing operation ahead and then returns to saw the joints that were skipped.

412.2.4 Expansion Joints

Check that transverse expansion joints are properly constructed at the locations specified. Verify that preformed joint filler material is placed at all structures, manholes, inlets, and other projections into the pavement.

412.3 PLACEMENT AND CONSOLIDATION OPERATION

412.3.1 Moistening of Grade

Just ahead of the placement operation, verify that the grade is kept moist without creating standing water or soft spots. Additional sprinkling of the grade may be required throughout the day, especially during hot, dry, and windy conditions.

412.3.2 Hauling and Delivery Considerations

For each load, retain the delivery ticket and check that the required information is provided. Refer to subsection 601.06 of the Standard Specifications for details on delivery tickets

requirements. Check the mix for acceptability. The mix should be visually similar from load to load with respect to uniformity and consistency (i.e., slump). Pay particular attention to signs of segregation, and verify that the mix temperature is within acceptable limits. Ensure that molds for strength tests are cast as required and that air and slump tests are performed as specified. Verify that the concrete is completely discharged within the required time limits, especially from non-agitating trucks. When water is added to truck mixers, record the additional quantity, verify the water-cement ratio and record the number of mixer revolutions before discharge. Pay particular attention to any unacceptable movement of joint and reinforcement materials when the concrete is deposited.

412.3.3 Spreading and Strike-Off Considerations

Concrete shall be deposited uniformly over the base ahead of the strike-off operation. Concrete should be placed so that minimal rehandling is necessary. Where hand methods are needed, verify that shovels, not rakes, are used. Workers with muddy boots should not be permitted to walk through the freshly placed concrete. Ensure that any footprint areas are properly vibrated.

412.3.4 Vibration Considerations

The concrete should be vibrated across the full width of the slab. Observe consolidation and require any needed frequency adjustments. When the equipment train halts, verify that vibrators are shut off. If any vibrator malfunctions, halt the operation until it can be effectively repaired or replaced. Verify that hand-held vibrators are used to consolidate concrete adjacent to forms and joint assemblies.

412.4 SURFACE FINISHING OPERATION

412.4.1 Floating Considerations

After the concrete has been placed, struck off, and consolidated, the floating operation will begin. Hand floating finishing is only permitted to finish areas inaccessible to finishing equipment (e.g., narrow widths, irregular shapes) and for short periods where finishing equipment breaks down. The Contractor should not use the CDOT test bridge for the finishing operation. Verify the grade and cross-section of the floated surface for conformance. Check for surface irregularities and enforce the Contract provisions with respect to stopping work and correcting surface defects. Check the edge for rock pockets and edge slump. A consistent concrete slump will promote a consistent slab edge.

412.4.2 Adding Water to Surface

The Contractor shall not be permitted to add water or finishing aids (water with a small amount of chemical) to the surface for the purpose of finishing the concrete. The intent is to ensure that the concrete placed will be high quality and durable. In situations where the surface

becomes dry and difficult to finish, as evidenced by tearing, paving shall cease and adjustments be made to the concrete mix or paving sequence.

412.4.3 Surface Texturing

Verify that the surface is textured in an acceptable manner. The acceptability of the surface texture is determined by CP 77 Method B. If the texture is deficient, identify the limits of the deficiency. Deficient surface texture will be corrected by diamond grinding prior to pavement smoothness testing. Consider the following guidelines:

1. Plastic Turf/Burlap. Where plastic turf and burlap are used, verify that the dragging operation completely covers the surface and produces a uniform gritty texture. The drag material should be maintained clean and free of dry mortar. Require replacement of the material as needed to ensure production of an acceptable texture. Burlap should be maintained in a moist condition during the operation; however, the quantity of added water shall not be enough to introduce additional water to the surface of the concrete.
2. Diamond Grinding. Diamond Grinding shall be uniform in appearance. Diamond grinding shall not occur prior to the concrete achieving a compressive strength of at least 2500 psi.

412.4.4 Stationing

Verify that stations are imprinted on the pavement surface at the specified locations.

412.4.5 Rumble Strips

Verify that rumble strips are placed where specified (e.g., deceleration lanes, ramps, shoulders). Check the size, shape, depth, and orientation of the strips for conformance.

412.5 CONCRETE CURING OPERATION

Immediately after finishing, check that the surface and edges are completely and uniformly sprayed with an approved impervious membrane material at a rate of at least 1 gallon per 180 square feet of pavement surface. Concrete shall not be exposed for more than 10 minutes before being covered with curing compound. Edges and irregular areas will usually be sprayed by hand. Halt paving if operations are not balanced sufficiently to ensure timely and adequate treatment. Ensure that all membrane damaged within 72 hours of application is immediately repaired. The Contractor shall be adequately prepared to protect the pavement from rain and cold weather damage. Use strength tests to verify compressive strength before allowing equipment to operate on the new slab.

412.6 SLAB REPAIR WORK

Know the conditions requiring repair work and the limits of removal and replacement. Coring should be used as needed to verify questionable areas. Enforce the Contract provisions with respect to repairing deficient areas. Verify that spalled joints and cracks are corrected as specified.

412.7 SURFACE SMOOTHNESS TESTING

After the concrete has cured sufficiently to support the smoothness testing operation, test the pavement (i.e., mainline, shoulders, ramps) according to the method specified. Consider the following guidelines:

1. Contractor QC Smoothness Testing. The contractor shall perform the following QC operations for smoothness testing:
 - a. Profiler. After the concrete has cured sufficiently to support the smoothness testing operation, 1,000 psi for a light weight profiler (LWP) or 2,000 psi for a high-speed profiler (HSP), the contractor will perform QC testing of each day's paving, high speed or light weight. The profiler is operated by Contractor staff; this testing does not have to be in the presence of a CDOT inspector. The profiler shall be certified according to CP78 to test concrete pavement. A list of certified profilers can be found on the CDOT website at <http://www.coloradodot.info/business/designsupport/design-docs>. The contractor's staff must be properly trained and have a current LABCAT Level S certification. Retain a copy of the operator's certification.

Prior to QC testing the contractor shall submit a traffic control plan for approval.

Test results from the QC smoothness testing must be submitted to the Engineer within 48 hours after testing. The test results shall show the Half-car Roughness Index (HRI) for each 0.1-mile section and areas of localized roughness. Paving should be suspended when test results show corrective work is required. Paving will remain suspended until the contractor proposes corrective actions in writing to the Engineer

- b. Straightedge. A 10-foot straight edge is supplied by the contractor. The straightedge method performed by the Contractor will be employed in areas not requiring testing by the profiler or areas that could not be tested by the profiler. Observe the operation, document deviations greater than 3/16 of an inch.
2. Department Initial Smoothness Acceptance Testing. The Department's High-Speed Profiler will be used for acceptance of the concrete pavement. This testing is performed prior to any corrective work to set the incentive & disincentive for each 0.1-mile section

and to designate areas requiring corrective work. To prepare for the Department's testing the contractor shall perform the following:

- a. Submit a traffic control plan that will allow the continuous collection of data for a lane. The traffic control plan shall allow the department's profiler to run the length of the lane without stopping
- b. The contractor shall mark the paving limits and each excluded area.
- c. The contractor shall lay out a distance calibration site. This site may be outside the project limits, but must be checked by the inspector.
- d. The lanes must be in their final configuration and allow the profiler to test in the intended direction of traffic.
- e. The lanes shall be free of debris and construction activity while testing.
- f. This testing cannot occur when the pavement is wet or icy.

When the contractor is ready for acceptance, they must submit a written request at least 10 days before they want the testing to occur. Since the Department only has one profiler, the contractor's requested date may not be available and will need to be rescheduled. The project will schedule the department's profiler by calling the Staff Materials and Geotechnical Branch's Concrete Unit at 303398-6548 or 303-398-6549.

After the testing, a report for each lane will be sent to the project showing the HRI for each 0.1-mile section, the incentive/disincentive for each 0.1 mile section and areas requiring corrective work. If the contractor performed any corrective work prior to this initial smoothness testing, the engineer shall reduce the incentive for any 0.1-mile section where the contractor performed corrective work to \$0.00 even if it was a short distance of grinding. The disincentive will not be changed.

3. **Corrective Work.** The contractor will perform the indicated corrective work and any additional corrective work to reduce disincentive payments. Once the corrective work is completed, recheck the acceptability of the corrected final surface with respect to texture and skid resistance. Joint sealant and pavement markings damaged by grinding shall be removed and replaced.
4. **Department Final Smoothness Acceptance Testing.** The Department's High-Speed Profiler will be used for acceptance of the concrete pavement. This testing is used to check that the contractor performed and fixed all areas of corrective work and to reduce the disincentive payments. The testing and contractor's responsibilities are the same as the initial smoothness testing.

After the testing, a report for each lane will be sent to the project showing the HRI for each 0.1-mile section, the revised incentive/disincentive for each 0.1-mile section and areas requiring corrective work. Each 0.1-mile sections showing an initial disincentive can have that disincentive reduced or eliminated, but that section cannot earn incentive.

If corrective work is still indicated, the contractor shall perform the corrective work and the lane will be retested by the Department. For every retest after the first Final Smoothness Acceptance Testing, the contractor will be charged \$500.

412.8 JOINT SAWING AND SEALING

412.8.1 Sawing Operation

Verify that the location of cuts that are sawed over load transfer devices are within specified tolerance. On the same day joints are to be sealed, verify that the saw cuts are properly cleaned and that all residue is removed from the joint reservoir and surface (e.g., flushing with water, sandblasting, compressed air). Follow the requirements of subsection 107.25 of the Standard Specifications for concrete slurry removal.

412.8.2 Sealing Operation

The sealing operation will begin after completion of all corrective work, joint sawing, and curing. Immediately prior to placement of the backer rod and sealant material, verify that the joint reservoir is further cleaned with compressed air. Pay particular attention to any oil or moisture that may be blown into the cavity. This will prevent the sealant from bonding with the walls of the reservoir. Require additional cleaning as needed. The sealing operation should not be conducted during wet weather conditions or when the ambient temperature falls below the manufacturer's recommendations. Verify that the sealant material is properly stored, prepared, and heated prior to application. Check the acceptability of the installed backer rod and sealant material (e.g., depth, height in relation to slab surface). Require the Contractor to clean any sealant material that may have smeared on the pavement surface.

412.9 PAVEMENT THICKNESS DETERMINATION

Ensure that the Contractor's coring operation conforms with the requirements of the Contract Specifications and the Contractor's Process Control Plan (see Section 412.1.3). Pay particular attention to the frequency of coring required for the mainline, shoulders, intersections, and miscellaneous areas. Verify that the Contractor documents daily thickness measurements. Acceptance tests must be witnessed by the Project Inspector and will be based on the length of core samples measured at the time the cores are taken by the Contractor. Determine the average length of cores and require additional coring as specified for deficient areas. Enforce the provisions of the Contract with respect to any needed price adjustments and the removal

and replacement of unacceptable slabs. Verify that the Contractor properly fills all core holes left in the pavement.

412.10 TRAFFIC CONSIDERATIONS

Where appropriate, ensure that the Contractor provides adequate maintenance of traffic through the construction zone (e.g., crossovers for construction equipment and public vehicles). Construction traffic should not be permitted on the pavement until the sawing and sealing operation has been completed. The pavement shall not be opened to traffic until the test specimens obtained during the placement of the concrete indicate that the pavement has reached its minimum specified strength.

Figure 400 - 1

GUIDELINES FOR INTERPRETING NON-STANDARD READINGS USING THE MIT-SCAN-2

When verifying dowel placement using the MIT-Scan-2 for dowels placed using a dowel bar inserter (DBI) machine or when using dowel baskets, some detailed exceptions have been observed:

A common cause of incorrect dowel bar placement is incorrect sawing of the transverse joint. The specification requires: The Contractor shall detail his methodology for ensuring correct marking of dowel bar insertion points and correct sawing of the joints. There may be instances with dowel baskets where additional analysis and engineering judgment may be required to make a final determination of the acceptability of the placed dowel bars.

The Engineer is encouraged to discuss the proposed dowel placement and potential MIT-Scan-2 reading exceptions at the Pre-construction or Pre-pave conferences to determine a method of handling these conditions.

This guidance is attached for your reference. Before applying these guidelines, ensure the MIT-Scan-2 device has been calibrated properly and settings entered correctly.

SECTION 413 RESERVED

SECTION 414 RESERVED

SECTION 415 RESERVED

SECTION 416 RESERVED

SECTION 417 RESERVED

SECTION 418 RESERVED

SECTION 419 RESERVED

SECTION 420 GEOSYNTHETICS

420.1 PRELIMINARY CONSIDERATIONS

Geosynthetics (e.g., geotextiles, geogrids, geomembranes) are specified for many types of applications. For the material to function as intended, it is important that the specified type of material be furnished and properly placed. Before the application of geosynthetics, consider the following guidelines:

1. Contract Plans and Specifications. Review the Contract, including Special Provisions, with respect to the type of application, limits of treatment, and material, construction, measurement, and payment requirements.
2. Material Considerations. Various types of geosynthetics are available for different applications. Check the material delivered for conformance.
3. Geosynthetic Technician. Where required for paving applications, verify that a technician from the geotextile supplier is present for technical advice.
4. Surface Preparation/Tearing Considerations. Pay particular attention to the surface upon which the geosynthetic will be placed. The surface should be reasonably smooth to a grade that conforms to the intended application. Observe the surface for items that could tear the material. In addition, the cover material should be placed carefully to avoid ruptures and tears.

420.2 INSPECTION GUIDELINES

420.2.1 Paving Applications

Geotextiles are typically used in paving applications for crack reduction. Consider the following guidelines:

1. Surface Preparation. Before the material is laid, verify that the surface is properly cleaned. Power brooms are generally used for this purpose.
2. Asphalt Cement Binder. After cleaning and before the fabric is laid, check that the asphalt cement is applied at the specified temperature and rate, and is the same grade as the asphalt cement used for item 403.
3. Fabric Placement. Immediately after the application of asphalt cement, the fabric should be laid. Verify that the geotextile fabric is placed within the limits of the Contract Plans with proper overlaps at joints and without wrinkles or tearing. No more

fabric than that which can be covered by a subsequent asphalt mix course should be applied during the work day.

4. Traffic Considerations. To avoid damage, check to ensure that equipment does not park or make sudden starts, stops, or short turns on the fabric. Traffic on the fabric should be minimal.

420.2.2 Impervious Lining Applications

Geomembranes are typically used for impervious lining applications. Check to ensure that the geomembrane is loosely laid to avoid rupture and that wrinkles are smoothed where practical. Verify that field lap joints are properly placed and that the joint contact surfaces are cleaned and treated with bonding adhesive as specified. Enforce the provisions of the Contract with respect to any needed repairs.

420.2.3 Erosion Control and Drainage Applications

Geotextiles are typically used for erosion control and drainage applications. The manner in which the geotextile is laid should minimize displacement of the fabric by water. Check that the fabric is loosely laid in the direction of water flow and anchored as required. Verify that trenching is placed at the top of slopes where designated on the Contract Plans. Check joint overlaps and sewn seams for conformance.

420.2.4 Subgrade Applications

Geotextiles and geogrids are typically used in subgrade applications. Prior to placement, inspect the prepared surface for acceptability. Consider the following guidelines:

1. Fabric Placement. The fabric should be placed in the direction of construction traffic in a relatively stretched condition without wrinkles or folds and secured as specified. Folds that are in the direction of construction traffic are acceptable on curved sections. Do not allow the fabric to be dragged across the subgrade. Verify overlaps at joints for conformance and inspect the fabric for damage prior to placement of cover material. Enforce the Contract provisions with respect to any needed repairs.
2. Cover Placement/Compaction. Verify that the placement, grading, and compaction operation for the first lift of cover material conforms to specified requirements. Watch for damage to the fabric caused by the compaction operation and ensure that needed repairs are made.
3. Traffic Considerations. Enforce the provisions with respect to equipment traffic (e.g., minimum thickness of cover, type and weight limitations). In general, equipment should not make turning movements on the first lift of compacted cover. Watch for fabric damage and subgrade rutting and ensure that any needed repairs are made.

420.2.5 Landscape Applications

Geotextile fabric is typically used for weed barriers in mulched landscape applications. Prior to placement, verify that the soil has been properly prepared and graded. Check to ensure that the fabric is placed loosely, lapped in the direction of water flow, and anchored as required. Where designated on the Contract Plans, verify check slots are provided at the top of slopes. Also check for the installation of metal landscape borders where required.

CDOT CONSTRUCTION MANUAL

SECTION 500 STRUCTURES

SECTION 501 STEEL SHEET PILING

501.1 GENERAL

Sheet piling is typically specified in Contracts for applications such as cofferdams and cutoff walls at the base of retaining-wall footings. In such applications, sheet piling provides a tight interlocking bulkhead that restricts the lateral movement of material behind it. The Contract will designate the location, extent, and type of sheet piling required. The primary duty of the Project Inspector is to verify that the Contractor furnishes the correct material and properly installs the sheet piling.

501.2 INSPECTION GUIDELINES

501.2.1 Before Construction

Consider the following guidelines before the pile driving operation begins:

1. Contract Plans and Specifications. Review the Contract with respect to the designated limits of treatment (e.g., location, driving depth, cut-off elevation) and the type of sheet piling. Pay particular attention to splicing, welding, and painting requirements.
2. Types of Sheet Piling. The Contract will designate the type of sheet piling required. Upon delivery, review the Mill Test Reports to ensure that the heat numbers on the sheet piles correspond to those on the reports. Document the width and length of each sheet pile. Where painting is designated in the Contract, check that the sheets are in accordance with the Contract Specifications. Two types of sheet piling may be designated in the Contract. Consider the following:
 - a. Type I. Where Type I sheet piling is designated, verify that the piling is corrugated, non-galvanized steel sheeting of the interlocking type. Check the material grade, thickness, and section modulus for compliance.
 - b. Type II. Where Type II sheet piling is designated, check that the material grade and thickness conform to the requirements for steel sheet piling.

501.2.2 During Construction

Consider the following guidelines during the driving of sheet piling:

1. Driving Head. Verify that a driving head is used during the operation. Check for damaged piling and enforce the Contract provisions with respect to pulling and replacing damaged piling.

2. Penetration. Verify conformance of the method used to determine acceptable penetration (e.g., measured depth, refusal).
3. Cut-Off Elevation. Where a sheet extends above the designated cut-off elevation, ensure that it is cut to the required elevation by an approved method. Document the area of cut sheets that are not used at other locations or for splice work.
4. Splicing. Where a standard length of sheet piling must be driven so that its top is below the designated cut-off elevation, verify that additional sheeting is spliced (i.e., cut, installed, and welded) to raise the height of the piling to the required elevation. Check the cutting and welding operation for acceptability. Where multiple splices are needed, ensure that the minimum specified distance between splices is not exceeded. Document the number, width, and length of splices performed and accepted.

SECTION 502 PILING

502.1 GENERAL

Structural steel shapes are typically used as foundation piles. These piles are driven vertically or near vertically into natural ground to help support the structure and minimize settlement. Without a solid foundation, the attention given to constructing a quality structure is meaningless. As such, the Project Inspector must thoroughly and competently inspect the foundation piling provided for structures.

Many types of piles are available for foundation designs, and each design will differ based on the specific conditions at the site. The Contract will designate criteria such as pile type, number, length, horizontal arrangement, orientation (i.e., plumb, batter), and driving specifications such as design load, driving energy, depth, and number of blows. Each pile that is driven to specification will provide a bearing capacity that will support a fraction of the structure's total load (i.e., design load). The pile's bearing capacity results from a combination of resistant forces, including the surface friction between the pile and natural ground and the bearing pressure of the pile tip on the substrata material (e.g., bedrock).

Although it is equally important to check items such as pile type, location, and orientation, it is paramount to continually inspect the driving operation. If driving is stopped too soon, the pile will not have developed the required bearing capacity to resist the design load, and the structure may eventually settle due to a lack of support. If overdriven, the pile may incur structural damage, increasing the chance that the foundation will settle or otherwise fail at the location of the damaged pile.

502.2 INSPECTION GUIDELINES

502.2.1 Before Construction

Significant information will need to be documented with respect to pile driving. See Appendix B for an example of a completed Piling Form.

502.2.1.1 Contract Plans and Specifications

Review the Contract with respect to equipment requirements and pile type, length, location, orientation, anticipated driving depth, structural refusal, bearing capacity, and cut-off elevation. Review the splicing, capping, and painting requirements.

502.2.1.2 Pile Location and Utility Considerations

Verify that utility locations have been staked and that any known conflicts have been resolved before the operation begins. Review to ensure that all pile locations have been properly staked in accordance with the Contract.

502.2.1.3 Excavation

Where excavation is required, check the limits of excavation (i.e., plan dimensions and depth) for compliance. Unless otherwise authorized, excavation must be completed and accepted prior to driving foundation piles.

502.2.1.4 Equipment Considerations

Various types and energy ratings of pile drivers are available. Equipment selection depends on the type and size of piles to be driven. More than one type of driver may be required for the project. Based on the methods and criteria specified in the Contract, the Project Engineer will determine equipment acceptability before delivery to the job site.

This task generally involves analysis and comparison of data supplied by the Contractor and, if questionable, further inspection and testing (e.g., pile driving analyzer). As soon as practical, provide the Contractor with written notification of equipment acceptance or rejection. Verify that the Contractor furnishes the pre-approved equipment and ensure that substitutions are not made during the work. Otherwise, equipment acceptability must be reassessed. Consider the following guidelines:

1. Hammer Cushion/Striker Plate. Hammer cushions and striker plates are typically used to ensure uniform driving behavior and minimize damage to the pile. Where required, verify conformance with respect to type and size.
2. Pile Driving Head. Where a pile driving head is required, verify compliance with the manufacturer's recommendations.
3. Pile Driving Leads. Pile driving leads are typically used to guide the movement of the hammer, thus ensuring the pile receives a concentric impact with each blow. It is essential that the fall of the hammer be in line with the pile; otherwise the head of the pile may be severely damaged, the hammer may be damaged, the energy of the hammer may be reduced, or the pile may change direction. Also, check lead alignment to ensure that it does not hinder the movement of the hammer.
4. Followers. Where required, verify the proper use of followers.

502.2.1.5 Material Considerations

Use the following guidelines to inspect materials for the pile driving operation:

1. **Pile Types.** The pile types that are typically used in foundation applications include structural steel shapes, steel pipe, and steel shell piles. The Contract will designate the types required. Upon delivery, review the Mill Test Reports to ensure that the heat numbers on the piles correspond to those on the Reports and that the piles have been manufactured in the United States of America. Also, check and document conformance with respect to pile condition, material grade, length, and cross-sectional shape and dimensions.
2. **Pile Tips.** Where their use is specified, check pile tips and fastening details for compliance.
3. **Concrete.** Concrete is used to fill the interior of steel pipe and steel shell piles after they are driven and their interior cleaned of debris and water. Where specified, check the concrete class for conformance.

502.2.1.6 Test Piles and Pre-drilling

As designated or directed, test piles will be used to determine the need for pre-drilling. In general, if a test pile is driven to specification without reaching the designated minimum penetration depth and bearing elevation, pre-drilling will be required. Check and record the location, depth, and diameter of all pre-drilled holes. The hole diameter depends on the type and size of pile required. This ensures that the pile will be in an accurate and stable position for driving. If the maximum diameter is exceeded, verify that voids are backfilled as specified.

502.2.1.7 Welder Certification

As needed for splice work, ensure that welders are prequalified for the work. Check each welder's Certificate of Qualification. Ensure that the document complies with the minimum period of satisfactory performance for the type of welding to be performed. Retain a copy of all Certificates of Qualification.

502.2.2 During Construction

During the driving of foundation piles, consider the inspection guidelines in the following Sections. See Appendix B for a sample piling form.

502.2.2.1 Pile Location and Direction

Verify that each pile is driven within tolerance of its designated location. Also, check pile alignment (i.e., vertical, batter) for deviation from allowable tolerance. Verify that pile flanges

are oriented as designated in the layout of the Contract. Watch the pile as it is driven for sudden changes in direction. This is a good indication that the pile has failed below the ground surface. In such cases, contact the Engineer of Record for assistance.

502.2.2.2 Hammer Cushion/Striker Plate

As needed during driving, inspect the integrity of cushions and striker plates for compliance. Pay particular attention to the thickness of the material and require replacement based on the minimum specified thickness.

502.2.2.3 Water Jetting

Water jets, where authorized, are used to facilitate pile penetration. Ensure that water jets are removed, as specified, for the final depth of penetration. Once removed, determine average penetration using test blows.

502.2.2.4 Pile Penetration and Bearing Elevation

Piles must be driven to virtual refusal into natural ground so that the elevation of the tip of the pile is at or below the designated bearing elevation. At bridge structures, the bearing elevation of the pile must be below the 500-year scour depth. Check and document pile elevation, number of blows at minimum final penetration, and final depth of the pile. Consider the following guidelines:

1. **Adjacent Piles.** Where a new pile is being driven, closely monitor the elevation of adjacent piles. In some cases, adjacent piles will tend to “push up.” Ensure that the Contractor re-drives affected piles to the proper bearing elevation.
2. **Sudden Changes in Penetration.** Monitor the pile for sudden changes in penetration between blows. This usually indicates that the pile has failed or an unusually soft subsurface strata has been encountered. Sudden disappearance of the pile confirms the presence of a cavern or large void. In such cases, contact the Engineer of Record for assistance.
3. **Unusually High Bedrock.** Where the designated penetration depth and bearing elevation cannot be obtained without damaging the pile (e.g., encounter with unusually high bedrock), contact the Project Engineer for assistance. Pre-drilling may be required.
4. **Springing/Bouncing.** Watch for pile springing and hammer bouncing. Springing may occur where spliced members are not properly aligned, the pile head is not squared properly, or the pile and hammer are misaligned. Bouncing may occur where the pile has reached the point of virtual refusal, a hammer of insufficient weight is used, or too much steam or air pressure is used in double-acting hammers.

5. Pile Driving Analyzer. The Project Engineer will determine the number and location of piles to be monitored by a pile driving analyzer. If the Contractor is directed to setup the analyzer and monitor the piles, check and document the number and location of piles that were monitored and the results of the analysis.

502.2.2.5 Cutting of Piles

Ensure that the piles are cut by an approved method and to the correct cut-off elevation. Check that the cuts made at splices are normal to the longitudinal axis of the pile. Document the pile location, the pile's initial length, and the length of pile that was cut. Pay particular attention to the disposition of cut lengths of piles. They may or may not be reused. If reused in field-splice work, document the pile location and the length of pile that was reused.

502.2.2.6 Pile Splicing

For those piles driven deeper than the minimum penetration depth, splicing may be necessary to raise the top of the pile to the correct cut-off elevation. Either commercial splices or field-welded splices may be used. Check for acceptability and document the location, type, and number of all splices. Where commercial splices are used, check that they are of an approved type and fastened in accordance with the manufacturer's recommendations. Thoroughly inspect welding for compliance with respect to welder certification, surface preparation, root opening, welding method, type of weld, number and order of passes, and removal of slag.

502.2.2.7 Filling and Capping of Hollow Piles

After steel pipe, shell piles, and the adjacent piles have been driven and accepted, inspect the inside cavity using the Contractor-supplied lighting system. Pay particular attention to buckling or crushing. Ensure that water and debris are removed from within the pile before the Contractor fills the interior with the designated class of concrete.

502.2.2.8 Pile Damage and Defects

During the driving operation, continually monitor piles for damage and defects, and review the provisions of the Contract with respect to corrective work. Pay particular attention to head damage, internal damage, splice defects, and improper pile location, direction, and final bearing elevation. Contact the Project Engineer and the Engineer of Record as needed for assistance. Defective piles may need to be removed and replaced, or they may be permitted to remain with the provision of another treatment (e.g., new adjacent pile, footing adjustment, additional extension). Note any unusual conditions encountered. Re-inspect all corrective work.

502.2.3 After Construction

Once foundation piles have been driven to specification, verify that the pile tops are cut square. Ensure that all loose material is removed from around the piles before the foundation concrete is poured.

SECTION 503 DRILLED CAISSONS

503.1 GENERAL

Caissons are relatively large-diameter, underground columns of reinforced concrete that are constructed in pre-drilled holes to provide foundation support for structures. They are designed to transfer and distribute structural loads to underlying strata through side shear and end bearing. In general, caisson construction consists of drilling a hole at a designated location, depth, and diameter; constructing and placing a cage of reinforcing steel; and placing and finishing concrete to the elevation required by the foundation details of the Contract.

503.2 INSPECTION GUIDELINES

503.2.1 Before Construction

Before the construction of drilled caissons, consider the following guidelines:

1. **Contract Plans and Specifications.** Review the Contract with respect to the requirements for reinforcing steel and concrete materials and caisson location, depth, diameter, and elevation. Pay particular attention to the caisson drilling sequence and dewatering requirements.
2. **Caisson Location/Utilities.** Verify that utility locations have been staked. Verify that all caisson locations have been staked in accordance with the Contract.
3. **Boring Log/Geological Reports.** Review the boring log and geological reports. Become familiar with the appearance of the type of material anticipated at the depth of the bearing strata.
4. **Blasting.** The use of explosives for caisson construction is not permitted.
5. **Materials.** Check to ensure that the type of reinforcing steel and class of concrete conforms to specified requirements. Where steel casing is required, verify conformance with respect to wall thickness, strength, diameter, and condition.

503.2.2 During Construction

503.2.2.1 Drilling Operation

Where holes are drilled for caissons, consider the following:

1. **Location.** Check the location of the center of the shaft to ensure it is within allowable tolerance from that designated in the Contract.

2. **Depth of Embedment.** The designated bottom elevation is specified, which may be revised by the Project Engineer to ensure proper load bearing capacity. Document the depth drilled into the target bearing strata, and compare the excavated material with geological information to ensure that adequate bearing material has been reached.
3. **Diameter/Sides.** Check the hole diameter and sides to ensure compliance to size, vertical orientation, and allowable tolerance. Where caving is encountered, halt the operation until the situation can be evaluated and corrected. Protective steel casing may be needed.
4. **Excavated Material/Cleaning.** Check to ensure that the hole is dewatered and cleaned of all loose material. If dewatering is not practical, the provisions of the Contract with respect to placing concrete under water will govern.
5. **Protective Covers.** Once the hole has been accepted, verify that protective covering is installed to prevent persons and materials from falling into the hole.
6. **Shale / Claystone Considerations.** Where a caisson is to be socketed into shale / claystone, the reinforcing cage, support system, and concrete must be placed within the specified time limit after drilling. If the limit is exceeded, require the Contractor to drill the specified additional depth into the shale / claystone just prior to placement of the concrete, and verify that the reinforcement cage is adjusted to the new depth.

503.2.2.2 Caisson Reinforcement/Steel Casing

Caisson reinforcement will consist of a single-unit cage of reinforcing steel. The cage must be inspected prior to being placed into the drilled hole. Consider the following:

1. **Cage Construction.** Inspect the cage for proper bar size, spacing, and fastening. Check the cage height and diameter for conformance.
2. **Steel Casing.** Where designated or as directed, ensure that the proper size of steel casing is installed prior to placement of the cage, support system, and concrete.
3. **Installation Timing.** After the hole and cage have been inspected, the cage and support system must be installed in the hole just prior to pouring concrete. If the concrete is not immediately poured, require removal of the cage, re-inspect the hole for loose material, and check the surface condition of the steel for acceptability.
4. **Support System.** A support system must be provided so that the cage does not sit on the bottom nor lean against the wall of the hole. Check conformance with respect to the number and interval of spacers along the length of the cage. Verify that the support system does not rack or skew the cage, and require additional steel as needed to stiffen the cage.

503.2.2.3 Concrete Placement

Acceptability of the placement method used for concrete will depend on whether the hole is considered dry or wet. Just prior to placement, check the depth of water at the bottom of the hole. If the depth, without pumping, is less than approximately two inches, the hole may be considered dry for the purpose of method approval. Otherwise, the hole should be considered wet. Consider the following guidelines:

1. **Dry-hole Placement.** Where the hole is dry, the concrete may be poured continuously in a free fall from the surface with the use of a hopper or approved device. Check to ensure that the concrete does not hit the reinforcing cage or the sides of the hole on the way down.
2. **Wet-hole Placement.** For wet holes, the Project Engineer must review the proposed method of placement. The Contract provisions regarding placement under water will govern. Verify that the hole is dewatered.
3. **Vibration Operation.** Check the vibration operation for compliance with respect to the minimum depth of concrete consolidation at the top of the caisson.
4. **Removal of Water-Diluted Concrete.** Where water-diluted concrete has floated to the top of the caisson during the pour, verify that the minimum depth of the top surface is removed and wasted as specified.
5. **Steel Casing.** Unless otherwise designated or directed, the steel casing shall be removed from the caisson.
6. **Concrete Curing.** Check that the top surface of the concrete is properly cured.
7. **Adjacent Construction.** Where work for foundation piles, excavation, or caissons is to be performed adjacent to the freshly poured caisson, check compliance with respect to minimum lateral clearance and compressive strength requirements.

503.2.3 After Construction

Verify that the projecting reinforcing steel is in the correct location and properly cleaned of mortar.

503.2.4 Caisson Construction Inspection Documentation

The CDOT Form No. 1333 should be used as a minimum standard for the as-built documentation of each caisson (drilled shaft) installation. Assistance with inspection can come from CDOT's Material and Geotechnical Branch or a geotechnical consultant.

Structures

Some of the site-specific geotechnical items to review include depth to bedrock, groundwater elevations, overburden soil and bedrock material types, and potential for caving soil. The inspection staff should be able to perform a visual field verification of the soil/rock material for comparison to supplied geologic boring logs.

The inspection staff should consider the need for the following equipment.

1. Weighted 100-Foot Tape
2. Mirror / High Intensity Light
3. Plumb Bob

The Inspection Staff should regularly communicate with the Engineer regarding the progress of installation, any irregularities, and the quality of the contractor's methods and means.

SECTION 504 WALLS

504.1 GENERAL

Mechanically Stabilized Earth (MSE) walls are earth-retaining structures that are constructed by placing alternating layers of reinforcement and compacted soil behind a facing element to form a composite material, which acts integrally to restrain lateral forces. MSE walls are gravity structures that are relatively flexible and can tolerate horizontal and vertical deformations. MSE walls can be used in cut situations, though they are most efficient in fill or embankment applications.

504.2 INSPECTION GUIDELINES

504.2.1 Before Construction

The Contractor shall submit six sets of shop drawings and certified material test reports for review prior to construction of the wall.

Before construction begins, consider the following guidelines:

1. Wall Layouts. Review the Contract with respect to the location, limits, and type of wall-required lines, grades, starting, corner and end stations, leveling pad step breaks, total number of panels and top and bottom wall elevations. Pay particular attention to the shop drawings and submittal requirements outlined in Revision of Section 504. Form 1401 - Block Faced MSE Wall Submittal Checklist or Form 1402 - Panel Faced MSE Wall Submittal Checklist shall be submitted with the Shop Drawings.
2. Panel and Reinforcement Locations. Panel to panel, panel to reinforcement connection detail, and limits of special panels at curved wall corner shall be shown.
3. Wall Elevations. Except for the top of the leveling pad, wall elevations given on the plans are based on the desirable wall height.
4. Soil Reinforcement Materials. Review the material requirements with respect to color, size, shape, efflorescence, and test results for freeze and thaw durability of block and or panels, etc. Visually observe the samples if a submittal requirement is included. Ensure the soil reinforcement type meets the Long-Term Design Strength (LTDS) of the Ultimate tensile strength, TULT (MARV) for geosynthetic soil reinforcement or LTDS for metallic soil reinforcement.
5. Soil Reinforcement Length. See table for minimum reinforcement length requirements.

6. Panel Size and Soil Reinforcement Spacing. Verify requirements for minimum soil reinforcement spacing.
7. Long Term Design Strength (LTDS) of Reinforcement. Verify requirements for long-term design strength of reinforcement.
8. Surface Preparation/Excavation. Verify the acceptability of the slope after it is prepared, including the bed for the leveling pad. Check the excavation for the toe or cut-off wall, where required, to ensure that it conforms to the lines designated in the Contract. Check for the need for over excavation for incompetent foundation material. If over excavation is needed, inspect the replacement Class 1 backfill material and operations.
9. Prior to construction, it is recommended to have a preconstruction meeting with the Contractor to review all checklists.

504.2.2 During Construction

The following Sections present inspection guidelines that should be considered during the construction of MSE walls.

504.2.2.1 Block Facing MSE Walls

The Inspector's Checklist for Concrete Block Facing MSE Wall shall be filled out during the construction of the Block Facing MSE Wall.

Review the specifications for additional requirements during construction.

504.2.2.2 Concrete Panel Facing MSE Walls

The Inspector's Checklist for Concrete Panel Facing MSE Wall shall be filled out during the construction of the Concrete Panel Facing MSE Wall and any Hybrid MSE Wall systems.

Review the specifications for additional requirements during construction.

SECTION 505 RESERVED

SECTION 506 RIPRAP, GABIONS, AND SLOPE MATTRESS

506.1 GENERAL

Erodible slopes within the right-of-way (e.g., along the banks around bridge structures) are typically treated with an erosion and sedimentation countermeasure. Three types of treatments may be designated: riprap, gabions, or slope mattresses. Riprap is the careful placement of relatively large, angular stone on the erodible slope. Gabions and slope mattresses, used on highly erodible banks, are similar to riprap, except that fabricated wire-cage units containing the graded rock are placed on the slope.

506.2 INSPECTION GUIDELINES

506.2.1 Before Construction

Before construction begins, consider the following guidelines:

1. **Contract Plans and Specifications.** Review the Contract with respect to the location, limits, and type of treatment required. Pay particular attention to the nominal size and material requirements of the stone, depth of treatment, and fabrication details for wire-cage units.
2. **Materials.** Review the requirements for riprap with respect to nominal size, shape, dimensional ratio, specific gravity, gradation, abrasion resistance, and compressive strength. Visually observe the required material samples from the quarry and site for compliance (i.e., size, angularity, gradation). Where the material is suspect, request laboratory results for verification or require the Contractor to provide the necessary equipment for gradation testing. Where gabions or slope mattresses are designated, check compliance of the tie wire, wire mesh, cages, anchor stakes, and stone material.
3. **Surface Preparation/Excavation.** Verify the acceptability of the slope after it is prepared, including the bed for gabions and slope mattresses. Check the excavation for the toe or cut-off wall, where required, to ensure that it conforms to the lines designated in the Contract.

506.2.2 During Construction

The following Sections present inspection guidelines that should be considered during the construction of riprap treatments, gabions, and slope mattresses.

506.2.2.1 Riprap Treatment

Check the limits of treatment and depth of stone for compliance. Pay particular attention to the placement of the final surface layer. The final surface shall appear relatively smooth with interlocking faces of adjacent stones.

506.2.2.2 Gabion Treatment

Gabions are wire cages (i.e., building blocks) that are filled with riprap material, placed, and tied to each other on the slope to provide a larger protective structure. Check the acceptability of the wire cages in terms of dimensions and perimeter edges (i.e., selvedged, bound). Ensure that the stone material is placed in the cages as dense as practical. Verify the units are placed closely together and tied to each other as specified.

506.2.2.3 Slope Mattress Treatment

Slope mattresses are similar to gabions except that the horizontal dimensions of the wire cage are much greater than the depth. Where slope mattresses are specified, verify the proper use of secured diaphragms within the cage. Their use will depend on the unit's length-to-width ratio. Each diaphragm contains the stone material in smaller cells within the mattress. Prior to filling, check that adjoining surfaces and edges of lids are tied as specified. Verify that each mattress is properly anchored with stakes. Where holes are predrilled for stakes, check the depth for compliance. Where wire cages are pre-fabricated and placed on the slope, ensure that damage to the zinc coating is properly repaired. .

506.2.3 After Construction

Walk the treated area and look for obvious signs of improperly placed stone, inadequate depth of stone, and misaligned or untied wire cages.

SECTION 507 SLOPE AND DITCH PAVING

507.1 GENERAL

Slope and ditch paving is used primarily for erosion and sedimentation control, but it also offers a neater appearance over other treatments, especially on slopes around major structures. Where designated in the Contract, the Project Inspector must ensure compliance as discussed in this Section.

507.2 INSPECTION GUIDELINES

507.2.1 Before Construction

Before slope and ditch paving begins, consider the following guidelines:

1. **Contract Plans and Specifications.** Review the Contract. Pay particular attention to the location, limits, depth, and type of paving required.
2. **Materials.** The materials required for the work will depend on the type of paving specified, which may include: concrete, reinforcing steel, grout, bituminous material, riprap, and dry rubble. Check the required materials for compliance (e.g., type, class, size, classification, gradation). Where dry rubble is required, do not allow the use of riprap material. The purpose of dry rubble is to provide a natural appearing slope around bridge abutments without introducing a rock slope that is potentially hazardous to the traveling public.
3. **Surface Preparation/Excavation.** Ensure that the area to be treated is properly prepared. Check the toe or cut-off wall excavation for compliance... The paving slope may need to be adjusted in the field to properly match the ditch line. This may occur where a road on steep grade traverses under a structure or where rough terrain does not permit a smooth transition with approach fill. Note that the paving slope designated in the Contract is the maximum allowed, and any required field adjustment must be in the direction of providing a flatter slope.

507.2.2 During Construction

Use the guidelines in the following Sections to inspect slope and ditch paving construction.

507.2.2.1 Concrete Paving

Where concrete slope and ditch paving is specified, check the mixing and placement of concrete for conformance. To enforce the Contract provisions for slip-form and hand placement methods, pay particular attention to the designated paving thickness and that, which is

proposed by the Contractor. Where required, check the acceptability of forms and the placement of reinforcing steel. Monitor the depth of paving for compliance, and ensure that expansion joint materials, where required, are placed at the proper thickness and location. Verify compliance with requirements for cold-weather paving, curing method and material, surface moisture, and curing period.

507.2.2.2 Dry-Rubble Paving

Riprap is not allowable where dry-rubble slope and ditch paving is specified. Check that larger stones are placed on the lower course. Verify compliance of joint location and treatment, total paving thickness, and the appearance of the final surface. Pay particular attention to oversize stones and protrusions that could present a safety hazard, and require immediate corrective action.

507.2.2.3 Grouted-Rubble Paving

Where grouted-rubble slope and ditch paving is specified, check the placement of the stone for acceptability. Inspect the joints prior to grouting and require cleaning as needed to remove soil and debris. Ensure that the elapsed time between grout mixing and placement does not exceed specified limits. Do not permit grouting during freezing weather. Check that all joints are properly grouted and that the grout is kept moist for the required curing period. This is especially important during hot, dry, and windy conditions. Verify that the final surface is swept to expose the faces of the rock without removing grout from the joints.

507.2.2.4 Grouted-Riprap Paving

Where grouted-riprap slope and ditch paving is specified, verify that the riprap material is properly placed. Where required, check weep holes with respect to bedding, pipe, geotextile fabric, and rock cover. Ensure that the elapsed time between mixing and placement of concrete mortar does not exceed specified limits, and do not permit mortar to be applied during freezing weather. Verify the use of pencil vibrators between rocks, and inspect mortar penetration for acceptability. Verify that the top layer of exposed rock is properly cleaned and the required height above the mortar. Check to ensure that the concrete mortar is properly finished and cured.

507.2.2.5 Bituminous Paving

Where bituminous slope and ditch paving is specified, check to ensure that the bituminous material is placed and compacted to the cross-section designated in the Contract. Verify that a fog coat is applied at the specified rate to the final surface.

507.2.3 After Construction

After construction, ensure that excavated areas that were not paved are properly backfilled with acceptable material and tamped to the level of the original ground.

SECTION 508 TIMBER STRUCTURES

508.1 GENERAL

The requirements for timber structures, as well as portions of other structures that are timber, are governed by the provisions specified in Section 508 of the Standard Specifications.

508.2 INSPECTION GUIDELINES

508.2.1 Before Construction

Before beginning work that involves treated and untreated timber members, consider the following guidelines:

1. **Contract Plans and Specifications.** Review the Contract. Pay particular attention to material requirements and designations for timber grade, working stress, and preservative treatments. Know where and how specific timber members are to be arranged, fastened, primed, and painted.
2. **Timber Members.** Upon delivery, inspect the timber members to ensure that they are grade-marked by a grading agency certified by the American Lumber Standards Committee. As needed, reference the Lumber Inspection Agency Certification Grade Verification Guidelines contained in Appendix D. Check the certificate of inspection to ensure that it designates the correct destination and project.
3. **Fasteners/Incidental Materials.** Fasteners that are typically used in timber construction include bolts, washers, nuts, drift pins, dowels, nails, and screws. Check compliance with respect to the type and size of materials required. Pay particular attention to thread length and galvanization requirements.
4. **Shop Drawings.** Bridges made from timber require shop drawings to be submitted. The Project Engineer will send the drawings to the Staff Bridge Branch for processing according to Section 105.2.3.

508.2.2 During Construction

Consider the following guidelines during the inspection of work involving treated and untreated timber members:

1. **Field Cuts/Drilled Holes.** Unless otherwise directed, treated timber will not be cut in the field. Where it is necessary and approved by the Engineer to cut or drill treated

timber, ensure that the Contractor properly applies the required preservative treatment to the exposed timber.

2. Construction Details. Check compliance of the following items with respect to type, size, location, grain orientation, clearance, and fastening details:
 - a. bracing and framing;
 - b. piling and posts;
 - c. bulkheads, longitudinal X-braces, trusses, and bent timbers;
 - d. treated fill pieces and dapping;
 - e. sills and caps, including sheet metal and burlap caps;
 - f. hot asphalt swabbing;
 - g. joints, blocking, and shimming;
 - h. stringers, floor planks, laminated flooring; and
 - i. handrails and handrail posts.
3. Bolts/Bolt Holes. Check the diameter of drilled holes for the type of bolt specified, and ensure that the correct type and number of washers are used.
4. Painting. Where designated in the Contract, check that wood and metal surfaces are properly cleaned, prepared, primed, and painted.
5. Structure Number. Check to ensure that the structure number is placed as designated in the details of the Contract.

508.2.3 After Construction

Perform a final review of the timber structure for obvious errors and omissions, and require immediate corrective action based on the provisions of the Contract.

SECTION 509 STEEL STRUCTURES

509.1 GENERAL

The work for steel structures, as designated in the Contract, will be governed by Section 509 of the Standard Specifications.

Prior to fabrication of steel structures, contact the Staff Bridge Fabrication Inspection Unit (303) 757-9339 to arrange quality assurance inspections.

See specification 509 for pre-erection requirements and see appendix A for the pre-erection conference agenda.

509.2 INSPECTION GUIDELINES

509.2.1 Before Construction

Many different activities must be performed before construction begins. Consider the following guidelines:

1. Contract Plans and Specifications. Inspection of steel structures requires a great deal of coordination, attention to detail, and a thorough working knowledge of the Contract documents. These documents include, but are not limited to, the following:
 - a. CDOT Standard Specifications;
 - b. Standard Special Provisions;
 - c. Project Special Provisions;
 - d. ASTM Material and Testing Specifications;
 - e. AASHTO Material and Testing Specifications;
 - f. AASHTO Standard Specifications for Bridges;
 - g. AISC Steel Construction Manual;
 - h. Bridge Welding Code ANSI/AASHTO/AWS D1.5;
 - i. Shop Drawings; and
 - j. Quality Control Process Control Plan.

Prior to the start of work, review this documentation and become familiar with the responsibilities of CDOT and Contractor inspection personnel; material sampling and testing requirements; fabrication, assembly, and erection details; welding and painting requirements; and the acceptance criteria specified in the Contract.

2. **Storage.** Do not allow bent or damaged steel members to be incorporated in the work without prior review by the Project Engineer.
3. **Shop Drawings.** Shop drawings are required for all steel structures governed under Section 509 of the Standard Specifications. Review the drawings and become familiar with the types and locations of steel and fasteners required, member identification and marking system, rolling orientation designations, types and location of welds, and the location, extent, and criteria for non-destructive tests.

509.2.2 During Construction

Consider the following guidelines during field assembly and erection:

1. **Material Inspection, Delivery, and Erection.** Watch for materials and work that have not been previously inspected and documented on the Form 193. Pay particular attention to the following:
 - a. **Straightening.** Straightening of bent members, check to ensure the process does not fracture or damage the member. Visually inspect members immediately after straightening and, if fractures are suspected, use magnetic particle and dye penetration testing for verification.
 - b. **Match Marking.** Check match marks on members and assemblies to ensure that they are arranged, assembled, and erected based on the Contractor's match-marking diagram.
 - c. **Coating Damage.** Watch for damage to shop coating (e.g., galvanization, paint) caused by mishandling upon delivery and during erection, and require the Contractor to make immediate repairs.
2. **False work Considerations.** Where false work is required, verify conformance with subsection 601.11 of the Standard Specifications.
3. **Bearings and Bearing Seats.** Where bearing devices are designated for steel structures, see Section 512.
4. **Field Welding Considerations.** With the exception of attaching studs, field welding is only permitted where designated in the Contract or as approved by the Engineer. The Engineer shall obtain written permission from Staff Bridge.

5. Bolt Installation and Inspection. The Staff Bridge Fabrication Inspection Unit will perform rotational capacity tests of all bolts on the project before installation. The Project Engineer will notify the Staff Bridge Fabrication Inspection Unit no less than 72 hours before installation. Connections must be drawn tightly together. All bolts in the connection must be installed before final tightening of the connection. Once the connection is complete, check bolts for proper tension, as specified.
6. Field Cleaning and Painting. After inspection and acceptance of erection work, verify that surfaces to be field painted are properly cleaned. Self-weathering steel will be cleaned but not painted to promote development of a uniform coat of rust. Ensure that a prime coat is applied to all uncoated surfaces to be painted, including damaged shop painted surfaces. Once the prime coat has cured, verify that the top coat is applied in the manner specified. Pay particular attention to the mishandling of painting materials, and enforce the Contract provisions with respect to mitigating environmental contamination.

509.2.3 After Construction

Upon completing the steel structure, consider the following guidelines:

1. Removal of Supports. Check that all blocking, supports, and false work are removed without damaging the structure.
2. Final Appearance. Check the fit and appearance of diaphragms, transverse bracing, field splices, and floor beam connections.
3. Damaged Coating. Verify repair of galvanized units on which the spelter coating has been burned by welding or damaged during erection.
4. Structure Number. Verify that the number stenciled on the structure is correct and placed in the proper location.

SECTION 510 STRUCTURAL PLATE STRUCTURES

510.1 GENERAL

Structural plate pipes are typically used in culvert and bridge applications. Depending on the particular needs of the application, the plates will be fabricated from steel or aluminum alloy and assembled to form an arch, elliptical, or circular pipe. To obtain full design strength, this type of structure depends primarily on the specified tensioning of bolts and backfill placement.

510.2 INSPECTION GUIDELINES

510.2.1 Before Construction

Before work begins, consider the following guidelines:

1. **Contract Plans and Specifications.** Review the Contract. Pay particular attention to the location, type and size of structure, excavation and flow line, assembly method and sequence, and material requirements. At the Preconstruction Conference, the Contractor shall state the type of material (steel or aluminum) they will use.
2. **Materials.** Check structural plates for conformance with applicable material specifications for steel and aluminum alloy.
3. **Manufacturer/Fabricator Certificates.** Verify that the Contractor has furnished the appropriate Certificates of Compliance. Also, check that the manufacturer has furnished the required data sheets.
4. **Field Coating.** Where designated in the Contract, check the application of field coating with respect to the material used, application method, rate of application, and number of coats applied.
5. **Damaged Coating.** Plates delivered with broken or bruised spelter coating shall be repaired in accordance with subsection 707.09 of the Standard Specifications.

510.2.2 During Construction

Consider the following guidelines during the work involving structural plate pipes:

1. **Excavation.** Check the width and depth of excavation (e.g., trenching) for conformance to the lines and grades designated in the Contract. Ensure the embankment has been completed to a height 0.3 of the rise above the flow line or 0.3 of the diameter of the structure before excavation. Check the bedding of the flow line for compliance paying particular attention to oversize rocks and rock protrusions.

2. **Test Pits.** Verify compliance of test-pit excavation with respect to the required number, location, and depth below the flow line. Where unsuitable foundation material is encountered, ensure that the material is removed to the minimum specified depth below the flow line and backfilled with suitable material.
3. **Field Cutting.** Where plates are cut to form skewed or sloped ends, check the angle of the cut for compliance. Ensure that the cut plates are numbered or match-marked as required.
4. **Spelter Coating.** Verify that damage to spelter coating caused by field cutting or welding is properly repaired in accordance with subsection 707.09 of the Standard Specifications.
5. **Assembly.** Watch for correct sequencing of plate assembly. Check to ensure that thicker invert plates are placed in the proper position. Check longitudinal and circumferential seams, joint staggering, and bolt connections for compliance with specified requirements. Require the Contractor to demonstrate that bolts have been tightened to within the specified range. After complete assembly but before backfilling, check all bolts for proper torque. After backfilling, perform spot checks to verify that uniform bolt tension has not been lost due to backfilling or vibratory compaction equipment. If the structure is assembled in other than its final location and is to be set in place after erection, all bolts must be tightened to specification requirements before lifting.
6. **Pipe Distortion.** Prior to backfilling, check to ensure pipes are not distorted and are properly set.
7. **Backfilling.** Check that backfilling complies with the details of the Contract. Watch for damage to the pipe and require immediate correction. Pay particular attention to the progression of the backfill operation. The height of the backfill on each side of the structure should progress equally in uniform compacted layers. This will minimize uneven lateral stresses on the structure.

510.2.3 After Construction

After assembly and backfilling, check the dimensions of the final cross-section (e.g., diameter, span and rise) and the grade of the flow line for conformance. Check to ensure that adequate earth cover has been placed and compacted before allowing heavy equipment traffic to operate over the structure.

SECTION 511 RESERVED

SECTION 512 BEARING DEVICES

512.1 GENERAL

Bearing devices are used in structures to allow movement (i.e., longitudinal, transverse, rotational) due to such factors as temperature change, post tensioning, and girder rotation.

512.2 INSPECTION GUIDELINES

512.2.1 Before Construction

Before work involving the installation of bearing devices begins, consider the following guidelines:

1. Contract Plans and Specifications. Review the Contract. Pay particular attention to the location and types of bearing devices required. Know the certification and installation requirements for each type of bearing to be installed.
2. Inspection Upon Delivery Testing and Acceptance. Prior to delivery, the Engineer may witness testing either at the plant or at an independent testing facility. Upon delivery, verify compliance with the required certification documentation. Retain all written certifications and applicable
3. Certificates of Compliance in the permanent project files. Check the documentation to ensure that the bearings have been delivered to the correct location and are the proper type for the structure. Check that each bearing is properly packaged to prevent damage and contamination. Verify that bearing components are marked where required. Reject bearings that fail to meet these delivery requirements.

512.2.2 During Construction

Consider the following guidelines during the installation of bearing devices:

1. Concrete Surface/Bearing Seat. Check to ensure that the concrete surface and bearing seat are within tolerance of the required elevation and horizontal or super elevated plane. Verify that the concrete surface is clean and free of cracks. Do not accept grout pads unless previously authorized by the Project Engineer.
2. Installation/Adjustment. Check to ensure that sole plates are positioned to the correct grade and super elevation and are in full contact with the bottom flange of the girder. Check the bearing alignment for conformance with the Contract. Verify proper adjustment for temperature, post tensioning, and shrinkage. Watch for interference between anchor bolts and the upper part of the bearing device.

3. Type III - Special Considerations. Verify that Type III masonry plates are set on the proper sheeting where monolithic cap seats are used. Ensure that a representative of the manufacturer of the Type III bearing is present to provide guidance during installation and to assist with inspection. Ensure the Type III bearing device does not move during girder placement or erection.
4. Protection of Bearings. Where welding is performed in proximity to non-metallic bearing pads, check for the proper use of wax pencils to monitor the heat generated and prevent damage to the pads. Where the structure is painted, verify protection from overspray and contamination.

512.2.3 After Construction

Perform a final check of the bearing devices and require corrective work based on the provisions of the Contract. Following completion of the superstructure, inspect the installation and alignment of each Type III device in the presence of the Contractor and the manufacturer's representative. Obtain written certification from the Contractor that the installation of all Type III bearing devices have been correctly installed.

SECTION 513 RESERVED

SECTION 514 PEDESTRIAN AND BIKEWAY RAILING

514.1 GENERAL

Pedestrian and bikeway railing is typically designated for pedestrian walkways and bikeways, including those combined with bridge rails across structures. Depending on the particular needs of the application, different designs and materials may be specified, including steel and timber.

514.2 INSPECTION GUIDELINES

514.2.1 Before Construction

Before work involving pedestrian and bikeway railing begins, consider the following guidelines:

1. **Contract Plans and Specifications.** Review the Contract. Pay particular attention to the type and limits of railing, material requirements, and fastening details (e.g., hardware and bracket locations).
2. **Materials.** Check that the type of railing delivered conforms to specified quantity, dimensional, and material requirements. In general, timber will be governed by Section 508, and steel by Section 509 of the Standard Specifications. For pipe railing, verify the coating (e.g., black, galvanized, painted, powder coated) and threaded and slip fittings for compliance. For steel tube railing, verify compliance of the steel tubes, plates, bars, fastening hardware, zinc coating, and prefabrication welding. For timber railing, verify that the correct fastening hardware has been delivered, and check that the timber members are pressure treated as specified. Upon delivery, verify the destination and project from the Certificate of Inspection, and inspect the timber members to ensure that they are properly grade-marked (see Section 508.2.1).
3. **Working Drawings.** Check that the Contractor has submitted the required working drawings. Review the working drawings and become familiar with the fastening details.

514.2.2 During Construction

Consider the following guidelines during the installation of pedestrian and bikeway railing:

1. **Posts/Rail Installation.** Check posts for proper location, alignment, and plumb tolerance. Check that the rails are rigidly braced and secured and that connections are tight and free of rattle and noticeable deflection.
2. **Fastening/Welding Considerations.** Check to ensure that bolts are long enough to extend beyond nuts and that the thread extensions are oriented away from pedestrian and bicycle traffic (i.e., the smooth, round heads of carriage bolts will face pedestrians).

Where welding is required, verify conformance with specified requirements. For timber members, verify that bolts are recessed as required. Check hand and rub rails for projections, and require immediate correction.

3. Electrolytic Isolation. Where dissimilar metals meet each other, electrolytic isolation will be designated in the Contract. Verify the proper installation of electrolytic isolation.
4. Painting. Where designated for non-galvanized pipe and steel railing, verify that the railing is properly prepared and painted with the designated color.

514.2.3 After Construction

After construction, ensure that all welds are ground smooth. Watch for burrs and sharp edges from cutting, punching, drilling, and tapping and ensure rounding where required. Check to ensure that paint and galvanization damage is properly repaired.

SECTION 515 WATERPROOF MEMBRANE

515.1 GENERAL

Waterproofing treatments (e.g., reinforced and elastomeric membranes, concrete sealer) are typically applied to concrete bridge decks. Concrete sealer is applied to bridge decks that will not receive an asphalt-wearing course. Waterproofing membrane is applied to bridge decks that will receive an asphalt-wearing course. The treatment is applied just prior to placement of the asphalt overlay. This minimizes potential damage to the treatment during construction.

515.2 INSPECTION GUIDELINES

515.2.1 Before Construction

Before the waterproofing treatment is applied, consider the following guidelines:

1. Contract Plans and Specifications. Review the Contract. Pay particular attention to the limits of treatment, type of waterproofing designated, sampling and testing requirements, and the method and sequence of operation.
2. Materials. Check the materials (e.g., membrane, sealer, primer) at the site to ensure they conform to the type designated for the project. Verify and retain applicable Certificates of Compliance. Verify compliance with sampling and testing requirements, and document test results.
3. Weather Considerations. Know the limitations of application with respect to inclement weather, surface moisture, and surface and ambient temperatures. Pay particular attention to required drying periods.
4. Concrete Curing. Check to ensure that the age of the concrete complies with specified limits before application of the treatment.
5. Surface Preparation. Before the treatment is applied, check to ensure that the concrete surface has been properly prepared. Pay particular attention to the limits of cleaning (e.g., bridge deck, approach slabs, height of curb above asphalt overlay, height of bridge rail above deck, sidewalks), sequence, timing, and methods (e.g., sand blasting, shot blasting, power washing, sweeping). Where waterproofing membrane is designated, verify that rough surface areas that could puncture or create air pockets in the membrane have been corrected.

515.2.2 During Construction

Consider the following guidelines during the application of waterproofing treatments:

1. **Primer Application.** If a primer is specified, verify the limits (e.g., height of curb above asphalt overlay) and application rate for conformance with specified requirements.
2. **Placement of Reinforced Membrane.** Check that the membrane is not placed too soon after primer application. Check the limits of placement (e.g., height of curb above asphalt overlay). Ensure that the membrane is overlapped in such a manner that a shingling effect will be achieved that directs runoff toward curbs and drains. Watch for wrinkles and air bubbles, and enforce the Contract provisions with respect to repairing such defects. Pay particular attention to flashing and priming requirements where membrane is placed near joints and drain pipes.
3. **Placement of Elastomeric Membrane.** Where elastomeric membrane is designated, check the limits of treatment and rate and thickness of application for compliance.
4. **Placement of Protective Covering.** Where protective covering is designated, do not permit any more membrane to be placed than can be properly covered in the same workday. Pay particular attention to the limits of covering and the required treatment of overlaps and joints.
5. **Concrete Sealant Application.** Contractor and CDOT personnel should follow the manufacturer's safety recommendations when applying concrete sealant. For protection, wear the Contractor-supplied respirators during the inspection of work involving concrete sealer. Verify the limits of treatment (e.g., height on bridge rails above bridge deck) and the application rate for conformance.

515.2.3 After Construction

Ensure that all corrective work to damaged waterproofing is completed as soon as practical. Immediately after the treatment has been inspected and accepted, notify the Contractor in writing of such approval and that the asphalt overlay can be placed. If the Contractor does not immediately place the overlay, it must be inspected again prior to paving.

SECTION 516 DAMPPROOFING

516.1 GENERAL

Where designated in the Contract, dampproofing of concrete surfaces will be governed by Section 516 of the Standard Specifications.

516.2 INSPECTION GUIDELINES

516.2.1 Before Construction

Before the dampproofing is begun, consider the following guidelines:

1. Contract Plans and Specifications. Review the Contract. Pay particular attention to the limits of treatment, type of material required, sampling and testing requirements, and the method and sequence of operation.
2. Materials. Check primer and asphalt dampproofing materials to ensure they conform to the type designated for the project. Verify and retain applicable Certificates of Compliance. Verify compliance with sampling and testing requirements, and document test results.
3. Weather Considerations. Know the limitations of application with respect to inclement weather, surface moisture, and temperature.
4. Concrete Curing. Check to ensure that the concrete has been cured before application of the treatment.
5. Surface Preparation. Before the treatment is applied, check to ensure that the concrete surface has been thoroughly cleaned.

516.2.2 During Construction

Consider the following guidelines during the application of dampproofing treatment:

1. Primer Application. Verify conformance with respect to limits, method, number of coats, and rate of application.
2. Asphalt Dampproofing Application. Verify conformance with respect to timing, method, and rate of application.

516.2.3 After Construction

After the asphalt, dampproofing has been applied, check for discoloring of concrete surfaces beyond the designated limits of treatment, and require the Contractor to properly clean the marred surfaces.

SECTION 517 WATERPROOFING

517.1 GENERAL

Where designated in the Contract, waterproofing of concrete surfaces will be governed by Section 517 of the Standard Specifications.

517.2 INSPECTION GUIDELINES

517.2.1 Before Construction

Before the waterproofing treatment is applied, consider the following guidelines:

1. **Contract Plans and Specifications.** Review the Contract. Pay particular attention to the limits of treatment, type of waterproofing material designated, sampling and testing requirements, and the method and sequence of operation.
2. **Materials.** Check the materials (e.g., asphalt primer, asphalt mop coat, woven cotton fabric) at the site to ensure they conform to the type designated for the project. Verify and retain applicable Certificates of Compliance. Verify compliance with sampling and testing requirements, and document test results. Pay particular attention to the method and temperature required for heating asphalt materials.
3. **Weather Considerations.** Know the limitations of application with respect to inclement weather, surface moisture, and surface and ambient temperatures. Pay particular attention to required drying periods.
4. **Concrete Curing.** Check to ensure that the age of the concrete complies with specified limits before application of the treatment.
5. **Surface Preparation.** Check that the concrete surface has been thoroughly cleaned. Verify that rough surface areas that could puncture or create air pockets in the treatment have been corrected.

517.2.2 During Construction

Consider the following guidelines during the application of the waterproofing treatment:

1. **Primer Application.** Verify the limits and method of primer application for conformance with specified requirements.
2. **Mop Coat Application.** Check that mop coat is applied at the specified locations and application rate.

3. **Fabric Placement.** Verify that the fabric is overlapped so that water will run over, not against, the laps. Check the lap width for conformance and that the laps are treated with mop coat. Watch for wrinkles and air bubbles and required immediate correction. Verify the application of mop coat over the entire surface of the fabric. Check to ensure this process is repeated as specified. Do not allow any more fabric to be applied that can be properly covered and sealed with mop coat in the same workday.

517.2.3 After Construction

After the waterproofing has been applied, check for areas that may allow water to infiltrate, such as improper overlaps and punctured fabric. Require immediate correction of any such defects.

SECTION 518 WATERSTOPS AND EXPANSION JOINTS

518.1 GENERAL

The installation of waterstops, expansion joints, and end dams is governed by Section 518 of the Standard Specifications. Expansion joint devices must not allow water to seep through the superstructure slab.

518.2 INSPECTION GUIDELINES

518.2.1 Before Construction

Before work involving the installation of waterstops, expansion joints, and end dams begins, consider the following guidelines:

1. **Contract Plans and Specifications.** Review the Contract. Pay particular attention to the installation details, material testing and certification requirements, and the locations, types, and sizes of devices required. The Contractor will provide the manufacturer and model number of the designated devices at the Preconstruction Conference.
2. **Materials.** Check devices and component materials to ensure they conform to the quantity, size, and type designated for the project. Verify compliance with sampling and testing requirements. The manufacturing plant and testing facility may be inspected for compliance by the Staff Bridge Pre-Inspection Unit. Ensure that the Project Engineer has accepted devices before they are installed. Verify and retain the manufacturer's written certification and applicable Certificates of Compliance.
3. **Working Drawings/Shop Drawings.** Do not accept working drawings or shop drawings that do not include the manufacturer's installation instructions. Review the drawings and become familiar with the component designations and installation details (e.g., center beams and support bars of modular expansion devices).
4. **Manufacturer's Literature.** Review the required manufacturer's installation literature to become familiar with the materials, components, adjustment settings, and installation details of the designated devices.
5. **Manufacturer's Representative.** Installation of expansion devices relies heavily on manufacturer's assistance and guidance. Ensure that the Contractor has properly notified the manufacturer of the need to provide a qualified representative during installation. Inspection certification will be required. Installation certifications are required from the Contractor or manufacturer, depending on the type of device.

6. Joint Opening Preparation. Check the joint opening for proper alignment, grade and dimensions as provided in the bridge plans and that the opening has been properly cleaned and prepared.

518.2.2 During Construction

518.2.2.1 Waterstops

Where waterstops are installed, verify proper installation. Ensure that the material is properly cut and spliced to prevent buckling and distortion. Check the position and shape for acceptability.

518.2.2.2 Asphaltic Expansion Devices

Where asphaltic expansion devices are installed, ensure that a qualified manufacturer's representative is on site during installation of the device. Verify with the representative that the device is being installed in accordance with the manufacturer's literature. Check conformance of the final thickness and grade.

518.2.2.3 Elastomeric Expansion Devices

Where elastomeric expansion devices are installed, ensure that a qualified manufacturer representative is on site during installation. Verify with the representative that the device is being installed in accordance with the working drawings and the manufacturer's literature. The Contractor shall set the joint opening in accordance with the temperature chart in the Contract Plans. Check that the device is properly set, supported, and secured. Where Portland cement concrete end dams are designated, verify the proper use of pressure injected grout and compliance with temperature and curing limitations. Verify that uncoated metal surfaces are properly cleaned and maintained. Check the final joint opening, grade, and elevation for conformance. Once installed, test the expansion joint for evidence of water seepage. If the test fails, require immediate correction, and retest the joint.

518.2.2.4 Modular Expansion Devices

Where modular expansion devices are installed, ensure that a qualified manufacturer representative is on site during installation of the device. Verify with the representative that the device is being installed in accordance with the shop drawings and the manufacturer's literature. The Contractor shall set the joint opening in accordance with the temperature chart in the Contract Plans. Verify that the maximum time between setting the joint opening and placement of the concrete is not exceeded, and measure and document the structure temperature as specified. Check for unacceptable bends or kinks and, if found, require replacement. Verify that recess openings in the deck and curb are properly primed with grout, filled with concrete, and finished. Ensure that uncoated metal surfaces are properly cleaned and maintained. Visually inspect concrete anchorages for conformance, and perform the

hammer test as specified. Require replacement if the hammer test fails. Check the final joint opening, grade, and elevation for conformance. Once installed, test the expansion joint for evidence of water seepage.

If the test fails, require immediate correction, and retest the joint.

518.2.2.5 Elastomeric Concrete End Dams

Verify proper installation based on assistance and guidance provided by the qualified manufacturer's representative. Enforce the provisions of the Contract with respect to corrective work.

518.2.3 After Construction

Obtain written certification (i.e., signed and dated) from the Contractor and the qualified manufacturer representative that the expansion devices and end dams designated for the project have been installed correctly.

CDOT CONSTRUCTION MANUAL

SECTION 600 MISCELLANEOUS CONSTRUCTION

SECTION 601 STRUCTURAL CONCRETE

601.1 GENERAL REQUIREMENTS

Section 601 of the Standard Specifications governs the construction requirements for major concrete structures such as bridges, retaining walls, and box culverts. Acceptability depends on the quality incorporated in the following distinct operations:

1. formwork, falsework, and framing;
2. reinforcing material and placement;
3. concrete mix materials, design, and production;
4. concrete placement and consolidation;
5. concrete finishing; and
6. concrete curing.

The Contract governs each of these operations in detail. Most problems encountered can be traced to materials and work that do not conform to specified requirements.

601.1.1 Completed Bridge Inspection

When construction of a bridge or overhead sign is completed, contact the Bridge Management Systems Engineer at (303) 757-9188 to schedule an inspection.

601.1.2 Vertical Clearances

The Project Engineer will verify the vertical clearance measurements for all bridges and overhead signs and report the findings to the Staff Bridge Branch and Staff Maintenance Oversize/Overweight Permits Office if less than 16 feet six inches. See Appendix D for guidance on measuring and reporting vertical clearances.

601.2 FORMWORK AND FALSEWORK

Falsework is used to support loads, including formwork, until the structure becomes self-supporting. Falsework design and construction are the Contractor's responsibility.

601.2.1 Form Lumber

To produce a clean, uniform finish on exposed concrete surfaces, acceptable form lumber must be used. Compliance will help ensure the desired surface appearance of the finished structure.

Attempts to cover up surface blemishes resulting from the use of marginal form lumber will not produce results equal to those that can be obtained from using acceptable form lumber. In addition, check that exterior corners are formed with a chamfer strip or other suitable means to produce smooth, even edges.

601.2.2 Bracing Considerations

The Contractor is responsible for providing adequate bracing of all formwork, and CDOT personnel cannot dictate construction methods. This poses a dilemma during construction, because inadequate bracing can sometimes cause bulges in abutments, wing walls, and retaining walls that, although undesirable, can be construed acceptable. Closely inspect all forms and bracing and accept the work only if it is clear that the Contractor could not have reasonably anticipated the situation. Doing so will help ensure the provision of a quality structure.

601.2.3 Foundation Systems

Adequate foundation systems must be provided to support the weight of falsework and construction loads. This is particularly important during the construction of concrete box girders and pier caps where segmental pouring sequences are employed. Partially completed structural elements cannot be expected to carry the weight of concrete used in subsequent pours, and adverse cracking will generally occur if falsework settles.

601.2.4 Falsework Drawing Certification

The Contractor's Professional Engineer shall determine the need for falsework drawings, as per subsection 601.11 of the Standard Specifications. Prior to placement of any concrete supported by falsework, the Contractor's Professional Engineer shall prepare and submit a letter of falsework certification to the Contractor. The Contractor shall submit the certification letter to the Project Engineer. The certification letter must contain the following information:

1. project number,
2. project code,
3. project location,
4. date,
5. Contractor's name,
6. name of Contractor's Professional Engineer,
7. structure identification,
8. description of portion of structure supported by falsework,
9. statement of certification

10. Professional Engineer's Colorado PE license number, and
11. drawings stamped "Approved for Construction".

The certification letter must be signed and dated by the Contractor's Professional Engineer. The statement of certification in the body of the letter will be as follows:

I hereby certify that falsework materials and construction have been inspected and that all falsework design, materials, and construction conform to the requirements of the Contract and are safe for the placement of concrete.

Note that a separate certification letter is required prior to each concrete pour that is supported by falsework.

601.2.5 Inspection Considerations

Before the concrete pour, thoroughly inspect formwork for trueness to line and grade, warping, smoothness of form faces, condition of form ties, proper bracing, tightness of joints, and cleanliness of forms (e.g., shavings, sawdust). Consider the following additional guidelines:

1. Falsework Drawings. Where determined necessary by the Contractor's Professional Engineer, verify that the falsework drawings are stamped with the registered seal of the Professional Engineer and approved and signed by the Contractor.
2. Letter of Falsework Certification. Verify that the Contractor has submitted a proper letter of falsework certification. See Section 601.2.4 for additional information.
3. Form Supports. Forms must be adequately supported and sufficiently rigid to minimize excessive deflection and distortion.
4. Concrete Finish/Surface Texture. Check that the surface of the forms complies with specified requirements for concrete finish and surface texture.
5. Form Release Agent. Ensure that the proper treatment (i.e., oil or form release agent) is applied to the forms prior to the placement of reinforcement.
6. Form Tightness. Form sections should be drawn tight to minimize mortar leaks at joints.
7. Metal Forms. Where metal forms are used, check sheet thickness and form design for compliance to ensure that forms will remain true to shape during the pour. Verify that form joints are properly aligned. The use of metal forms should produce a smooth concrete surface finish.
8. Chamfer Strips. Check that the specified types of chamfer strips have been properly placed in the corners of forms.

9. Form Ties. Where metal form ties are used, verify compliance with respect to type and number. The number of ties used should be sufficient to minimize bulging. Do not permit the use of twisted wire loops as form ties.
10. Omitted Backforms. The omission of backforms requires approval by the Project Engineer.
11. Embedded Materials. Ensure that all materials that will be embedded in the concrete (e.g., conduits, drains, utility blockouts, anchoring devices) are placed in the proper location and adequately secured.
12. Form Cleaning. Verify that the inside surfaces of the formwork are cleaned of all dirt, mortar, and foreign material.
13. Reuse of Forms. Where form panels such as plywood are to be reused, closely inspect the panels for acceptability before they are reused. Do not allow the reuse of unsuitable form materials.

601.3 CONCRETE PRODUCTION

601.3.1 Load Tickets/Mixer Truck Certification

Subsection 601.06 of the Standard Specifications requires the Contractor to furnish a load ticket (i.e., delivery ticket) with each load of concrete delivered to the project. The load tickets are used to verify compliance with specifications and to ensure that quality concrete is delivered to the appropriate location on the project.

Upon receipt of the first load, verify that the class of concrete delivered conforms to specified requirements and check that the information provided on the load ticket is accurate and complete. At the end of each day, obtain the load tickets from the Contractor and verify that the concrete meets specified requirements for the work in progress. Note that different classes of concrete may be specified for different structural elements. Perform verification checks as needed throughout the workday to ensure compliance. For bridge deck concrete, pay particular attention to the maximum allowable substitution of fly ash for cement.

Subsection 601.07(c) 3 requires the Contractor to provide a Concrete Truck Mixer Certification that shows the various pick-up and throw over configurations and wear marks so that wear on the blades can be checked. This certification shall be completed whenever the Contractor purchases a mixer truck. The Contractor shall provide the Engineer a copy of this certification with the correct date and current Project Number for each project. The Contractor will be required to complete a new certification only if the flights are changed and the wear marks are different from when the original certification was completed.

601.3.2 Deviation From Specifications

The Contract specifies many requirements for concrete production, which should be strictly and uniformly enforced to ensure that quality materials and workmanship are incorporated in

the structure. Any consideration to accept out-of-specification material must be based on sound engineering judgment to specifically address the problem encountered in the field and must have the approval of the Project Engineer. Always document the extent and basis of any deviation from specifications.

601.4 CONCRETE PLACEMENT

Consider the guidelines in the following Sections when inspecting the placement of structural concrete. See Section 601.7 for guidelines on placing concrete for bridge decks.

601.4.1 Before Placement

Use the following inspection guidelines before the concrete is placed:

1. **Mix Design.** Know the requirements of the designated concrete class, and check that the Contractor has obtained an approved mix design. Ensure that the type of fly ash to be used has been approved. Know the requirements for slump, air, and admixtures, including type and quantity.
2. **Pouring Schedule/Sequence.** The Project Engineer is responsible for approving pouring sequences and procedures. Know the pouring schedule from central or transit mixers.
3. **Truck Mixer Certification.** Check that the Contractor has provided a properly complete Form 46 - Concrete Truck Mixer Inspection Certification for each truck mixer used on the project.
4. **Time and Weather Requirements.** Check the specified time limitations and requirements for placing concrete during both hot and cold weather conditions. Verify that the Contractor is adequately prepared to protect fresh concrete from damage due to inclement weather (e.g., rain storms, freezing temperatures).
5. **Formwork.** Check lines, grades, and clearances of formwork, reinforcing steel and embedded fixtures for compliance. Verify that all dirt, chips, sawdust, water, and other foreign materials have been removed from formwork. Wood forms should be thoroughly moistened with water prior to the concrete pour. See Section 601.2 for additional guidance on formwork and falsework.
6. **Drainage and Weep Holes.** Check drainage and weep holes for proper location and elevation.

601.4.2 During Placement

Consider the following inspection guidelines during the placement of concrete:

1. **Load Tickets.** Check the information presented on load tickets as discussed in Section 601.3.1. Verify compliance with the mix design.

2. Mix Proportion Changes. Consult the Materials and Geotechnical Branch regarding any changes to mix proportions.
3. Adding Water. Ensure that the quantity of water added to the concrete mix at the site is properly recorded. Verify compliance with specified procedures for adding water (e.g., mixer drum revolutions, water/cement ratio).
4. Mixer Revolutions. Check that mixer revolutions are performed at mixing speed.
5. Chutes and Troughs. Verify that chutes or troughs are used properly.
6. Segregation. Check that the Contractor's method of placing concrete minimizes segregation.
7. Construction Joints. Verify that construction joints are properly formed at the correct location. Check that construction joints are cleaned and maintained free of debris and loose material.
8. Tell-tales. Check forms for obvious signs of weakness, such as panel bulges and settlement. Monitor tell-tales for settlement beyond acceptable limits, and required immediate corrective action.
9. Pour Sequence. Verify conformance with the designated concrete pour sequence.
10. Reinforcing Steel. Monitor the operation for reinforcing steel displaced by workers or concrete pours. Check that proper cover and clearance is maintained. Prior to placement of additional concrete, verify that extraneous mortar is cleaned from exposed reinforcing steel.
11. Reinforcement Dowels. Check that reinforcement dowels are properly installed at the correct locations.
12. Time Limitations. Monitor the operation to ensure that specified time limitations are not exceeded during concrete placement.
13. Consolidation. Check that vibrators provide adequate consolidation, thorough but not excessive. Do not permit vibrators to be used to move concrete along the forms.
14. Concrete Placed Under Water. Determine and verify the requirements for placing concrete under water.

601.5 CONCRETE FINISHING

Project Inspectors should closely monitor the finishing operation to ensure that all specified finishing requirements are being met. Various classes of concrete finish may be specified for any given structure, and the designated finish must be applied properly at the designated location. Do not approve a structure until the finishing operation has been thoroughly inspected

and found acceptable. A structure's appearance is only as good as the quality incorporated in the surface finish. Consider the following guidelines:

1. **Form Removal.** Check that forms are removed at the proper time. The concrete must be allowed to cure to a strength that will allow the structural member to support itself without damage when formwork and falsework are removed. Minimum strength criteria and number of days required before removal of forms will be specified in the Contract.
2. **Temperature Considerations.** Where a structural coating is designated, verify that the concrete surface temperature is within allowable limits before application.
3. **Joints.** Pay particular attention to construction and expansion joints during the finishing operation. Joint cavities must be maintained free of all mortar and loose concrete.
4. **Bridge Decks.** See Section 601.7 for guidance on finishing concrete bridge decks.
5. **Surface Preparation.** Verify that exposed surfaces are thoroughly cleaned by water and/or sand blasting at the proper time and that all irregular projections are removed. Check that all cavities, honeycomb spots, and broken edges are properly cleaned, saturated with water, and pointed and trued with the specified mortar mixture. Check that mortar patches are cured as specified.
6. **Types of Surface Finishes.** Verify that the designated class of finish is properly applied at the correct location. Although a Class 1 finish is not a comprehensive treatment, it is just as important as other surface treatments. Class 1 finishes are applied immediately after form removal. Before the application of a Class 5 finish or a structural coating, the concrete surface must be allowed to cure as specified. Where a structural coating is designated, check that the coating material and color have been approved, and verify the application rate and number of coats for compliance.

601.6 CONCRETE CURING

The requirements for the allowable methods of curing structural concrete are defined in the Standard Specifications and must be strictly enforced. Closely monitor the operation for compliance to all specifications. The surface of the concrete must be maintained in a moist condition for the minimum curing period, which includes the period during which the finishing operation is performed. Check that that Contractor is adequately prepared to protect the concrete and maintain the surface in a moist condition, especially during hot, sunny weather. Consider the following guidelines:

1. **Temperature Requirements.** Know the requirements for cold-weather concreting. Concrete must be maintained at the minimum specified temperature for the minimum number of curing days.
2. **Curing Method.** Verify that the Contractor's proposed curing method has been approved for the project.

3. Curing Compound. Ensure that the curing compound has been approved for use on the project, and verify the application rate for conformance.
4. Bridge Decks. See Section 601.7 for guidance on curing concrete bridge decks.

601.7 CONCRETE BRIDGE DECKS

The following Sections specifically address the construction of concrete bridge decks. Sections 601.1 through 601.6 provide additional information that should be considered for structural concrete work.

601.7.1 Pre-Pour Conference

A Structural Concrete Pre-Pour Conference will be held prior to the concrete deck pour to discuss project requirements with the Contractor. The Agenda for the Pre-Pour Conference is presented in Appendix A. During the various stages of the project, it is important to maintain communications with Contractor personnel (e.g., Superintendent, Foremen, Material Testing Supervisor) that have been established at the Conference.

601.7.2 Stay-in-Place Forms

Consider the following where stay-in-place steel forms are used in bridge deck construction:

1. Erection Drawings. Ensure that the Contractor has submitted erection drawings, and verify that materials and installation comply with these drawings.
2. Form Connections. Verify that form connections are made in compliance with specified requirements.
3. Welding Considerations. Monitor the operation to ensure that welding arcs do not come into contact with steel girder flanges.

Problems with forming concrete decks on precast prestressed concrete girders are typically due to inadequate haunch height. The haunch is the distance from the top of the girder to the bottom of the bridge deck. The haunch is specified by the designer on the plans and is designed to accommodate girder camber, deck geometry, and forming of the deck. It allows for the girder deflections due to the weight of the slab (dead load deflections).

Girder camber is due to the force of the tensioned prestressing strand and the time dependent effects of creep and shrinkage. Creep and shrinkage are a function of the actual concrete mix placed in the girder. Camber in a girder cannot be reliably predicted, since it is not known during design what the girder's age will be at the time of erection, the creep and shrinkage characteristics of the concrete mix, the concrete strength when the prestressing force is applied to the girder, and how these factors will interact.

Inadequate haunch height problems generally have been the result of:

1. The fabricator not monitoring the camber growth of the girders and taking corrective action when necessary, i.e. weighting the girders down.
2. The designer not allowing adequate tolerance for girder camber when specifying the haunch height.
3. The girders sitting on the bridge substructure for extended periods before the deck is placed.
4. The designer not making an allowance for the bridge deck geometry when determining the haunch height, for example, the effects of a vertical curve or the deck cross slope.

During construction, a number of different problems can develop that result in a difference between the haunch height specified on the plans and the actual haunch height in the field.

For example:

1. Less camber than predicted or failure to consider the effects of a crest vertical curve during design leads to a deeper haunch which can:
 - a. Increase the dead load on the girders and subsequently create additional dead load stress or deflection that the girder was not designed for.
 - b. Increase the height of the haunch, which probably was not planned for by the Contractor and is often discovered after the girders are erected. This often leads to conflicts and discussions about payment and time requirements for additional work. It may require ordering new forming materials.
2. More camber than predicted or failure to consider the effects of a sag vertical curve during design leads to a thinner haunch which can result in:
 - a. The inability to attain the minimum concrete bearing thickness under the ends of the precast concrete deck panels when the panels are used for deck forming.
 - b. Girders projecting into the deck, reducing the deck thickness over the girders and complicating the support of deck forming systems.
3. More camber than predicted due to:
 - a. The fabricator failing to support girder segments stored in the yard at the bearing seat locations at the end of the girders, or
 - b. The fabricator failing to weight the girders down, when there is an especially long period between girder fabrication and erection.

See the standard note on CDOT's prestressed girder worksheets for more information on the remedial action required by the Contractor to prevent excessive camber growth (B-616-BT, BX, SL, and U).

4. More or less camber than predicted due to bearing seats constructed at an elevation lower or higher, respectively, than that shown in the plans. As specified in subsection 601.12(l) of the Standard Specifications, - the Contractor shall provide an as constructed survey of abutments and piers prior to girder erection. Conducting this survey is important to predicting problems with haunch depth and allowing for any necessary adjustments prior to girder erection.

When problems arise, discuss the options with the Contractor, the bridge designer, the roadway designer, and the Area Engineer.

Options that may be considered:

1. Raising or lowering the grade of the bridge deck and approach roadway to accommodate the actual girder cambers, if possible.
2. Reducing the bearing thickness under the precast panels by using a grout as the panels are placed.
3. When metal stay-in-place deck forms are used, letting the girder project up into the deck and reduce the clearance between the bottom mat of steel reinforcement and the girder. In some cases, they may sit directly on the girder.
4. When precast box girders are placed side by side, there can be differences in camber between adjacent girders. This can result in a thinner slab or thicker slab than required on the plans at various locations and the clearance between the reinforcement mat and the tops of the girders will vary. This will require variable height chairs for reinforcement support.

601.7.3 Finish and Placement Considerations

To provide a smooth, uniform deck finish, it is important to balance the placement and finishing operation with the delivery of a uniform concrete mix. The delivery rate should be governed by the quantity of concrete that the Contractor's force and equipment can properly place and finish. The rate of placing and finishing should never be adjusted to accommodate a faster delivery rate. A proper balance will minimize frequent stops in the finishing operation, which usually creates humps in the deck. In addition, pay particular attention to slump and air content, because these factors greatly influence mix workability and consistency.

601.7.4 Concrete Placement Considerations

601.7.4.1 Before Placement

Consider the following guidelines before the concrete bridge deck pour begins:

1. Pre-Pour Conference. Verify that the Pre-Pour Conference has been held (see 601.7.1). Review the conference minutes, and check that the minutes have been updated, as needed, before each pour.

2. Temporary Traffic Control. Check that all provisions for protecting vehicle and pedestrian traffic have been adequately addressed.
3. Safety. Check that all safety items including handrails and toe rails are installed properly to protect workers and the traveling public.
4. Reinforcing Steel. Check the reinforcing steel for compliance immediately prior to the concrete pour.
5. Deck Machine Support. Verify that the deck machine is properly supported beyond the edge of the bridge deck.
6. Finishing Equipment. Verify that the screeding and finishing equipment has been checked for trueness. See Section 601.7.5 for additional information on finishing bridge decks.
7. Dry Run. Monitor the dry run of the finishing machine to ensure that the required thicknesses and clearances will result.
8. Test Slab. At least 14 days prior to initial placement of Class H, Class HT or Class S50 concrete on or in a deck the Contractor shall place, finish and cure a test slab according to the project specifications.

601.7.4.2 During Placement

Consider the following guidelines during the placement of bridge deck concrete:

1. Reinforcing Steel. Randomly check and document clearances of reinforcing steel.
2. Mortar Roll. Check for the proper quantity of mortar rolling ahead of the screed. A loss of roll will usually create a low spot, which will lack good consolidation.
3. Vibrators. Check that mechanical vibrators are being properly used to adequately consolidate the concrete.
4. Hand Work. Monitor the hand work used during the operation. Hand work should be kept to a minimum.
5. Slab Thickness. Check slab thickness for compliance using the stabbing method.
6. Finishing Machine. Verify that the finishing machine is providing a uniform, sealed surface finish with minimal ridges and voids. See Section 601.7.5 for additional information on finishing bridge decks.
7. Water. Ensure that the quantity of water applied for finishing is the minimal required and that application is performed using an approved fog spray.
8. Slab Surface. Before the concrete takes its initial set, check the deck slab for irregularities, and verify that the Contractor is performing straight-edge testing, as

specified. Ensure that the deck surface conforms to the requirements for pavement smoothness.

9. Joints. Monitor the operation to ensure that joints are properly constructed at the correct location. Where expansion joints are installed, consider the following:
 - a. Angles. Angles must be accurately set with respect to cross-section, grade, and curbing.
 - b. Anchor Bars. Check that anchor bars are correctly set and attached to angles.
 - c. Compression Joint Sealer. Verify that the compression joint sealer is installed in conformance with specified requirements.
 - d. Finger-Type Expansion Joint Devices. Where designated, check the vertical and horizontal alignment of the devices, and ensure that they are installed parallel to grade without lateral contact between fingers.

601.7.4.3 Bond of Cast-in-Place Concrete Deck to Precast Elements

The top surface condition of precast prestressed concrete girders and deck panels will affect the bond of cast in place concrete to these elements. Since this is a mechanical bond, factors such as surface roughness, dirt or debris on the surface, surface water, the substrate concrete's moisture condition, and consolidation of the deck concrete placed on the precast elements all can affect the bond. These factors also apply to the bond of thin concrete overlays to existing decks on bridge deck rehabilitation projects. Delamination at this interface can lead to deck failure.

When precast prestressed concrete deck panels, girders, or both are used, inspect these elements and have the Contractor remove all dust, dirt, water, and other deleterious substances from the top surface prior to placing the deck concrete. The bond of the cast-in-place concrete to the precast members is dependent on the cement paste flowing into the surface irregularities (pores) of the substrate concrete. Thus, any material that covers or fills these small voids or pores will inhibit the bond of the concrete and could lead to delamination and premature failure of the deck.

601.7.4.4 Bridge Deck Construction Joints

Construction joints (CJ) in bridge decks are used for various reasons, for example: to reduce the size of a deck placement or when an emergency bulkhead is needed to suspend a large deck pour. Ideally, construction joints should be located to allow the girders in a span to deflect and the ends to rotate under the weight of the entire deck. When CJ are not placed at correct locations, girder end rotation and deformation are restrained by the hardened concrete. Therefore, in the process of placing the deck on precast prestressed concrete girders, the ends of the girders in the next span should not be restrained until about 80% of the next span is placed. To approximate these conditions, a construction joint can be placed at about $80\% \pm 10\%$ of the span length as shown in the following examples.

During a deck placement (See subsection 601.12 of the Standard Specifications), the leading edge of the fresh concrete should be kept parallel to the substructure so that the girders are loaded evenly during the placing and screeding operations. Construction joints should be placed parallel to the substructure. Construction joints should be cleaned of surface laitance, curing compounds, and other foreign materials before fresh concrete is placed against the surface of the joint.

See Structural Concrete Pre-Pour Conference in Appendix A for the construction joint locations.

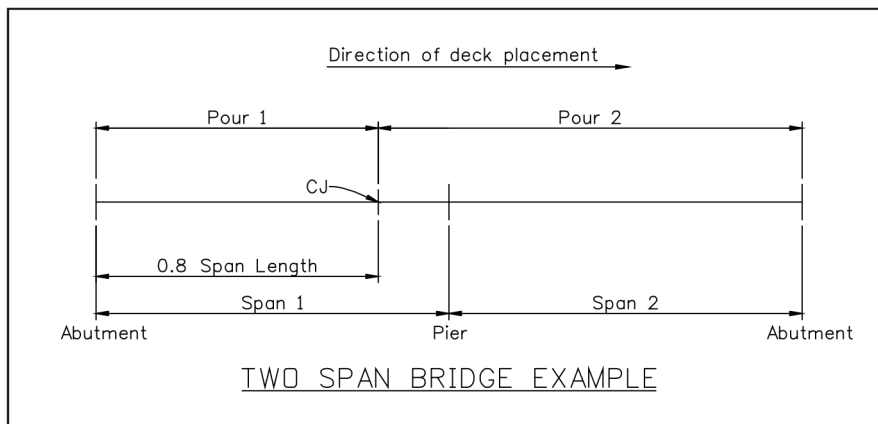
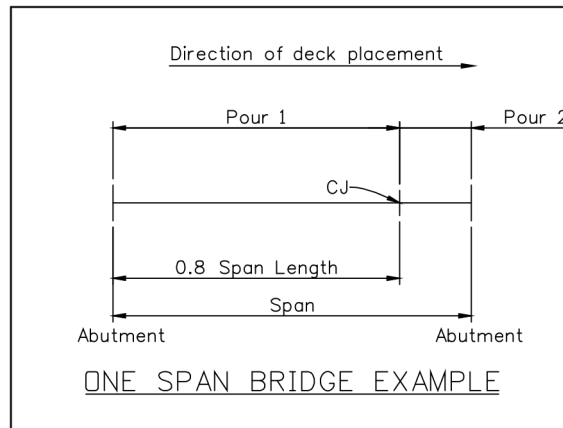

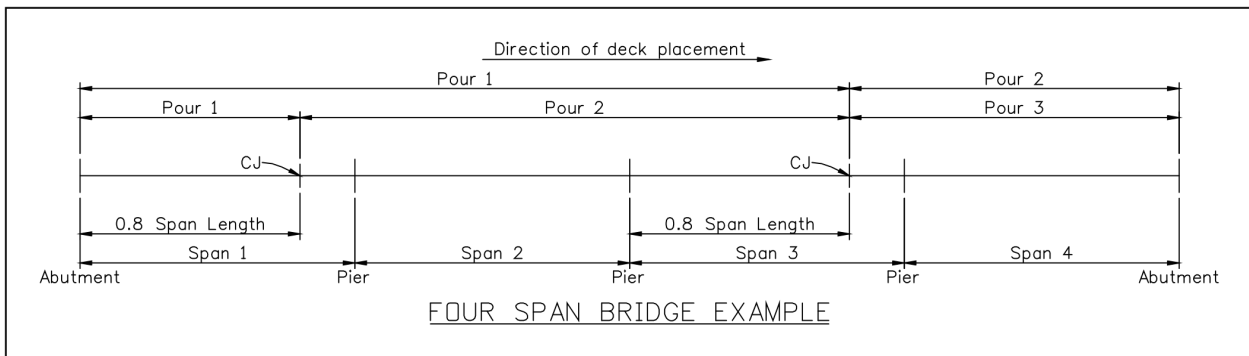
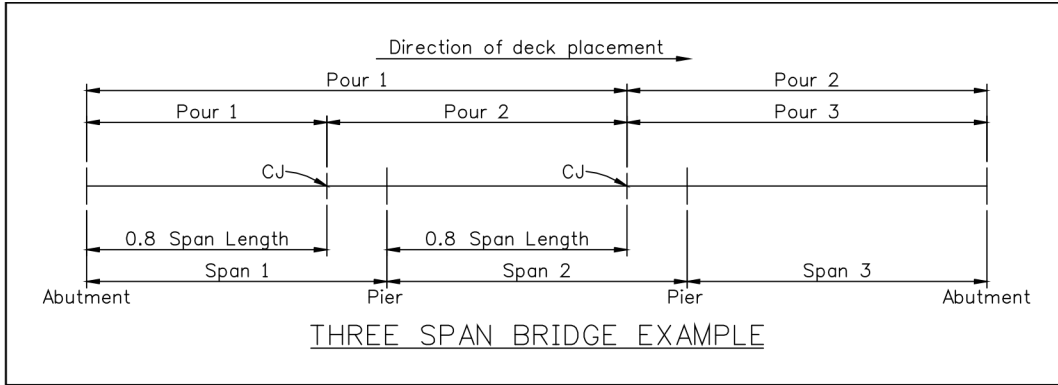

601.7.5 Concrete Finishing Considerations

601.7.5.1 Before Finishing

The Department requires the use of self-propelled mechanical finishers for all concrete bridge decks. The mechanical finisher is usually supported by a rail support system that is attached to the bridge deck, which transfers the load to the outside girders. If improperly installed, the use of a rail support system on welded plate or wide flange girders can cause thin decks or thick overhang sections, primarily due to girder rotation and overhang settlement. To prevent this condition, adequate cross-bracing must be installed between the outside and intermediate girders. Where rail support systems are installed, check that the spacing of the rail supports is sufficient to carry the load of the finishing operation without causing undue girder rotation or overhang settlement. In addition, check that the rail supports have been properly adjusted for the required alignment and grade. This adjustment check is typically performed using a string line to verify the grade at various locations along the deck while the mechanical finisher is moved into position.

601.7.5.2 During Finishing

Consider the following guidelines during the finishing of concrete bridge decks:

1. Hand Finishing. Because the use of self-propelled mechanical finishers is required for all concrete bridge decks, CDOT expects a higher quality surface in terms of smoothness and uniformity and a strict conformance to designated lines and grades. Therefore, hand finishing should only be permitted where it is necessary to remove surface irregularities such as:
 - a. holes and depressions resulting from test procedures,
 - b. surface tears caused by the screed, and
 - c. minor incidental deformities.
2. Plastic Turf Drag. When the final riding surface is the concrete surface, a plastic turf shall be dragged longitudinally over the full width of bridge deck after a seamless strip of burlap or other approved fabric has been dragged longitudinally over the full width of bridge deck to produce a uniform surface of gritty texture. Verify the proper dragging of a seamless strip of turf over the deck surface. Check that the drag material is maintained clean and free from encrusted mortar.
3. Grooving/Surface Texturing. Where designated for decks that will not receive a bituminous overlay, verify that the deck surface is properly textured.

601.7.5.3 After Finishing

Consider the following guidelines after the finishing operation:

Surface Check. Before the concrete takes its initial set, verify that all joints are tested with a straight edge and properly corrected. Check the entire slab surface for trueness, as needed, using a string line or a straight edge.

Joint Edges. Verify that joint edges are rounded with an approved radius hand tool, and that any tool marks on the adjacent surface are removed by brooming.

Surface Protection. Ensure that the finished surface is properly protected from damage due to traffic.

601.7.6 Concrete Curing Considerations

Immediately after the concrete is placed and finished, the deck will be cured and protected in accordance with specified requirements, including any Special Provisions.

Consider the following guidelines:

1. **Curing Method.** Verify that the method of curing has been approved and is following immediately behind the finishing operation without damaging the designated surface finish.
2. **Deck Cracking.** Cracks allow moisture and de-icing chemicals to penetrate the deck slab, and extensive cracking may affect the durability of the structure. Crack width is usually measured by inserting a wire gauge in the cavity. Contact the Staff Bridge Branch at (303) 757-9309 where crack widths of 0.02 inches or larger are observed. Where crack widths greater than 0.035 inches are found, ensure that the Contractor immediately repairs the cracks in accordance with subsection 601.15(i) of the Standard Specifications.

601.7.7 Approach Slabs

For joint or tied approach slabs, use the guidelines for bridge deck construction to inspect formwork, reinforcement, mix production, concrete placement, and the finishing operation. The inspection of approach slabs should be performed with the same diligence as for the bridge deck.

SECTION 602 REINFORCING STEEL

602.1 GENERAL

The design strength of reinforced concrete structures cannot be fully realized unless the specified reinforcing steel is placed as designated in the Contract. The type and size of reinforcing steel; bar location, spacing, and clearance; and the bond developed between the concrete and the bar surface are critical factors to consider during inspection.

602.2 INSPECTION GUIDELINES

602.2.1 Before Construction

Consider the following guidelines before work involving reinforcing steel for structural concrete and concrete bridge decks begins:

1. Mill Test Reports. Upon delivery, compare bar bundle tags with Mill Test Reports to ensure that bar size, material grade, and coating meet specified requirements. Spot check bar identification markings for proper steel grade.
2. Certificates of Compliance. Verify that Certificates of Compliance have been received.
3. Bar List. Verify that the Contractor's Bar List conforms to the Contract with respect to bar size, quantity, and bending details.
4. Bar Condition. Check reinforcing bars for mud, oil, rust, and detrimental scale. Concrete will only bond with a clean bar surface. In addition, check bars for straightness, and ensure that they are protected from damage. Ensure that any damage to epoxy coating is adequately repaired.
5. Bar Bending. Become familiar with the bar bending details. Where field bending is required, ensure that the proper procedures are being followed, and verify if the application of heat is permissible.
6. Additional References. As needed, consult the Concrete Reinforcing Steel Institute Manual of Practice for recommended placement practices.

602.2.2 During Construction

Consider the following guidelines during the placement of reinforcing steel for structural concrete and concrete bridge decks:

1. Bar Alignment and Spacing. Check that bar alignment and spacing conforms to the Contract. Verify that all bars and other embedded items are correctly placed so that the concrete can be adequately consolidated.

2. Bar Clearance. Check bar clearance and depth of concrete cover for compliance. Ensure that the proper minimum clearance is obtained between the top mat of deck bars and the surface of the concrete.
3. Bar Splicing. Check bar splices to ensure that they are the proper length for the type and size of bar placed. Note that epoxy-coated bars require longer splices than uncoated bars. Verify that bar splices are correctly staggered.
4. Bar Supports. The type, number, and spacing of supports must be adequate to minimize sagging, displacement, and damage of reinforcing bars. Plastic or epoxy coated supports are required for epoxy-coated bars.
5. Securing of Bars. To minimize displacement, bars must be securely tied. Verify that the bars are tied at all intersections or as otherwise designated. For bridge decks, check that the upper mat of bars is properly tied to the lower mat. Do not permit welding of bars except as noted in the Contract. Note that the use of coated ties is required for epoxy-coated bars.
6. Post-Tensioned Concrete. Adjustments made to reinforcement in post-tensioned concrete require approval by the Project Engineer.
7. Optional Form 279 (see Appendix B) can be used to document quantities of reinforcing steel for payment purposes.

SECTION 603 CULVERTS AND SEWERS

603.1 GENERAL

The acceptability of culvert and sewer installations depends on the extent to which material and construction conform to the Contract. Many factors must be considered during inspection, including:

1. structure alignment, elevation, and grade;
2. alignment of upstream and downstream channel, where applicable;
3. camber and end treatments;
4. bed preparation and condition and uniformity of bedding material;
5. backfilling method and material (see Section 206); and
6. embankment material and construction.

Culvert and sewer designs are typically based on the results of preliminary data collection and field investigations. Although adequate designs will be specified, it is common to discover situations that were not found during the field investigation or considered during design. Project Engineers and Project Inspectors should continuously monitor the construction operation and be watchful for situations that may warrant consideration of complete or partial redesign work.

603.2 INSPECTION GUIDELINES

603.2.1 Before Construction

Review the Contract for the location, type and size of culverts, and bedding required.

Consider the following:

1. Pipe Material. Upon delivery, verify receipt of proper material certifications. Inspect pipe and coating material for cracks, defects, and damage that may have occurred during shipping. Verify that smooth lined pipe is being used for irrigation and storm drain systems. Check pipes for proper:
 - a. class, type, and size;
 - b. thickness, gauge, and schedule;
 - c. coating and lining, and
 - d. lengths of sections.

2. **Safety Considerations.** Review the safety requirements for trenching operations and confined space entry. Do not enter manholes, inlets, vaults, trenches, or other confined spaces without taking the proper safety precautions.
3. **Staking.** Check that manholes, inlets, and pipes have been properly staked. Verify that staked locations and elevations are appropriate for existing field conditions.
4. **Utilities.** Verify that the Contractor has located all underground utilities. Ensure that all conflicts have been resolved.

603.2.2 During Construction

Consider the following guidelines during the construction of culverts and sewers:

1. **Grade Stakes.** Frequently check grade stakes for errors.
2. **Excavation.** Know the requirements for pipe installation in new embankments. Check excavation for correct depth, width, and alignment. Verify that the trench bed has been properly graded and compacted. Where rock is encountered during excavation, enforce the minimum depth of removal below grade.
3. **Bedding.** Check the type and depth of bedding for conformance.
4. **Placement.** Verify that pipe placement begins at the downstream end. Check that the entire length of pipe rests in contact with the bedding material at the proper flow line. Perform frequent alignment and elevation checks. Be exacting on sanitary sewer grades and flow-line smoothness.
5. **Pipe Jacking.** Where pipe jacking is required, verify the proper proportioning of the grout mixture. Check the roadway surface for signs of upheaval or failure, and require immediate corrective action. Where jacking is designated, proposed alternative methods require written approval by the Project Engineer.
6. **Pipe Joints.** Check the direction of joint laps for conformance. The bell or grooved end of concrete pipe or the outside lap of metal or plastic pipe must be placed in the upstream direction. Check that joints are properly sealed or banded and snug. Verify that joints are grouted, where required.
7. **Lift Holes.** Ensure that all lift holes are properly plugged.
8. **Pipe Damage.** Check in-place pipe for damage prior to backfilling and again before accepting the work. Ensure that any damage to coating or lining is properly repaired.
9. **Pressure Testing.** Prior to backfilling, check that storm drain and sewer lines have been pressure tested for water tightness as specified.
10. **Backfilling Operation.** Check the backfill material for conformance. Verify that the backfill material is being placed and fully compacted in lifts of the required thickness.

This operation must be performed equally and simultaneously on both sides of the pipe. Note that the required compaction must be obtained prior to placing successive lifts. Observe the operation to ensure that the method of compaction does not cause pipe damage or displacement.

603.2.3 After Construction

Prior to acceptance, verify that the pipe is properly cleaned and in good repair. Trenches in roadways must be properly resurfaced before opening to traffic.

Deflection testing is required at least 30 days after installation and backfill have been completed.

SECTION 604 MANHOLES, INLETS, AND METER VAULTS

604.1 GENERAL

Section 604 of the Standard Specifications governs the material and construction requirements for concrete manholes, inlets, and meter vaults. Unless the type is specifically designated, these items, or portions thereof, may be precast or cast-in-place.

See Section 601 for information on reinforced concrete structures and bridge decks, and Section 602 for information on reinforcing steel.

604.2 INSPECTION GUIDELINES

604.2.1 Before Construction

Prior to starting work on drainage structures, review the Contract. Verify existing drainage conditions, and check that the structures are staked at the proper location and elevation.

Consider the following:

1. Safety. Review safety requirements for trenching operations and confined space entry. Do not enter manholes, inlets, vaults, trenches, or other confined spaces without taking the proper safety precautions.
2. Precast Structures. Upon delivery of precast structures, verify receipt of proper material certifications. Check the type and dimensions of precast items for conformance. Where applicable, check the spacing of stair rungs for compliance. Pay particular attention to defects and damage that may have occurred during shipping.
3. Cast-in-Place Structures. Where cast-in-place structures are used, check forms and reinforcing steel for proper condition and dimension. Check the Contractor's Bar List.

604.2.2 During Construction

Consider the following during construction of manholes, inlets, and meter vaults:

1. Pipe Invert and Flow Line. Check pipe invert and flow-line elevations.
2. Manholes. A smooth flow line must be provided between manholes and pipes. Check that a good union with pipes is achieved. Where precast sections are used, check that neat joints are constructed. Verify the proper use of brick and mortar to make field adjustments.
3. Inlets. Check for proper dimension, formwork, concrete placement, and curing.

604.2.3 After Construction

Verify that all drainage structures are cleaned of any debris prior to accepting the work. Consider the following:

1. **Grates.** Check grates for acceptability with respect to type, dimension, orientation, and galvanization.
2. **Manhole Covers.** Check the type and dimension of manhole covers for compliance. Where located within pavements, check the slope and elevation of covers.
3. **Mortar/Grouting.** Verify that any needed mortar repairs and grouting around pipe are properly performed.

SECTION 605 SUBSURFACE DRAINS

605.1 GENERAL

Subsurface drains are installed to remove water from the roadway prism. Several different types may be designated. Underdrains may be installed to lower a high-water table, to intercept and dispose of water seeping into the roadway from sources outside the roadbed, or to intercept and control water seepage from the backslope. Edge drains are typically installed parallel to and near the edge of pavement to intercept water that seeps through the pavement surface courses.

605.2 INSPECTION GUIDELINES

605.2.1 Before Construction

Various types of pipe material may be designated for subsurface drainage. Know the locations where the designated types of pipe are to be installed, and consider the following:

1. Safety. Review safety requirements for trenching operations. Do not enter trenches or other confined spaces without taking the proper safety precautions.
2. Material Considerations. Upon delivery, verify receipt of proper material certifications. Check pipe materials for proper type (e.g., perforated, nonperforated), material grade, schedule, and diameter. Where corrosion resistant pipe is designated, pay particular attention to the specified material requirements. Check filter fabric material for compliance.
3. Staking. Check the location and elevation of staking for conformance.
4. Field Adjustments. Be alert for adjustments to underdrain locations that may be performed to enhance the functionality of the system.

605.2.2 During Construction

During the construction of subsurface drainage systems, consider the following guidelines:

1. Trench. Check trench location and shape for compliance. Perform grade checks regularly.
2. Bedding. Verify that the proper type of bedding material is being used. Check the depth of bedding for conformance.
3. Perforated Pipe. Verify that perforated pipe is being used at the proper location and that the pipe is being placed correctly with regard to the orientation of the perforations.
4. Joints. Verify that pipe sections are being securely fastened using the proper method of connection (e.g., connecting bands).

5. Filter Fabric. Verify that the proper type of filter fabric is being correctly placed. Watch for tears and contamination of the fabric material.
6. Filter Material. Check that the filter material is clean and uncontaminated. Ensure that the filter material is corrected where contamination such as dirt, clay, and vegetation is observed.
7. Backfilling. Verify that the backfill material is as specified and the backfilling operation does not damage the filter fabric.

SECTION 606 GUARDRAIL

606.1 GENERAL

Where guardrail and concrete barrier rail systems are warranted, they are installed to prevent errant vehicles from leaving the traveled way and moving into fixed objects, steep slide slopes, and opposing traffic. Different types of designs exist to address specific conditions.

606.2 INSPECTION GUIDELINES

606.2.1 Before Construction

See Section 210.2.1 and consider the following guidelines before installing guardrail and concrete barrier rail systems:

1. **Materials Considerations.** Check the type of rail system for conformance, including rail sections, hardware, and posts.
2. **Location.** Verify stake locations. Check lateral offset, longitudinal length, termini location, post spacing, rail curvature, parabolic flares, and trench width, where applicable.

606.2.2 During Construction

See Section 210.2.1 and consider the following guidelines during the construction of guardrail and concrete barrier rail systems:

1. **Guardrail Post Installation.** Unless designated otherwise, guardrail posts may be driven in place, set in dug holes, or set on a concrete base. Check post spacing, elevation, and alignment regularly. Where posts are driven, watch for irregular movement, possibly indicating an underground obstruction. Check driven posts for damage (e.g., distortion, burring). Where posts are set in dug holes, watch for overdrilling and require backfilling and compaction as needed to adjust depth and provide a firm foundation. After setting, verify that backfill material is placed and compacted in layers around posts. Check that all posts are set firm and plumb and that they are within tolerance of the required alignment and elevation.
2. **Cutting of Wood Posts.** Where wood posts are cut in the field, verify that the exposed surface is properly treated.
3. **Installation of Rail Sections.** Check that all fittings and metal plates are securely placed in the correct position. Check that rail sections are properly lapped in a smooth, continuous installation. Check that all bolts are drawn tight. Check the rail height and rail face (i.e., with respect to lateral offset and alignment) for conformance and any needed adjustment.

4. **Concrete Barrier Rail.** Concrete barrier rail may be either precast slipformed, or cast-in-place. Check the trench lines and grades for conformance and ensure that the base is properly compacted and watered before the barrier is placed. At transitions, check connection hardware for conformance and ensure that it is properly installed. Verify that cast-in-place and precast barriers are given a Class I finish and that slipformed barriers are given a vertical broom finish. Check that lift holes are properly filled and sealed. Ensure that the barrier is checked with a straightedge in the longitudinal direction and corrected where out of tolerance.
5. **Terminals and Transitions.** Pay particular attention to the construction details for end treatments, median terminals, and rail transitions (e.g., post type, post spacing, number of rail sections, lapping direction, splices, method of connecting, fastener type, reflector tab location). Specialized hardware and designs are commonly used at these locations and require close inspection prior to acceptance.
6. **Dissimilar Metals.** Where dissimilar metals contact each other, ensure that the surfaces are separated by an approved protective coating.
7. **Traffic Considerations.** Where the facility will be maintained open to traffic, it is good construction practice for the installation of rail sections to closely follow the installation of guardrail posts. At the end of the workday, check to ensure that, the termini of exposed rail sections are treated as specified.

SECTION 607 FENCES

607.1 GENERAL

Fences are generally placed within the CDOT right of way.

607.2 INSPECTION GUIDELINES

607.2.1 Before Construction

Consider the following guidelines before the installation of fencing begins:

1. Agreements. Check the right of way agreements for special fence requirements.
2. Material Considerations. Know the required type of fencing and gates. Check material certifications for compliance and document material condition. Check the weight, length, and coating of steel posts and the preservative treatment, straightness, and size of wood posts for acceptability. Verify that barbed and woven-wire fabric rolls are tagged with the required information. Check hardware for conformance. Concrete used for fence installation will comply with the requirements of Section 601 of the Standard Specifications. The use of field-mixed concrete requires previous approval.
3. Staking. Check that the staked alignment is approximately six inches inside CDOT right of way unless otherwise specified and that the post spacing is properly marked.
4. Temporary Fence. Verify if temporary fence is required (e.g., stock control, pedestrian safety, wetlands protection).

607.2.2 During Construction

Regularly check line, grade, and post spacing, and consider the following guidelines during the installation of fencing:

1. Posts. Check that posts are set at the specified depth and elevation. Verify that metal posts are set to face the correct direction.
2. Corner and Line Brace Posts. Check for properly located corner and line brace posts. Verify that line braces have been installed where needed for grade changes.
3. Concrete Curing. Concrete must be allowed to set sufficiently around posts and braces. Verify that the concrete has been permitted to gain the required strength before the fabric or wire is stretched.
4. Wire/Fabric. Know which side of the post the fence fabric or wire is to be installed. Check that the fence fabric or wire is properly stretched and fastened.

5. Sound Barrier. Where sound barriers are installed, verify that components are tightly abutted.
6. Vegetation Protection. Verify that plastic fencing is installed around vegetation that is to be protected.

607.2.3 After Construction

Ensure that no advertising tags or signs are placed on fencing or within the right of way.

SECTION 608 SIDEWALKS AND BIKEWAYS

608.1 GENERAL

Sidewalks and bikeways will either be concrete or bituminous paved facilities, as designated in the Contract. They are constructed on a solid foundation, typically bed course material that has been properly graded and compacted.

608.2 INSPECTION GUIDELINES

608.2.1 Before Construction

608.2.1.1 Subgrade

Check the cross-slope, elevation, and alignment of the subgrade for compliance. Where bed course material is required, ensure that the required type and depth of material is properly placed, shaped, and compacted. Check for soft spots, and enforce the Contract provisions with respect to needed repairs. Do not permit construction on a frozen base. Freeze-thaw cycles tend to loosen a compacted base. Recheck base density after freezing and thawing.

608.2.1.2 Curb Ramps

Review the location and construction details of curb ramps that are designated in the Contract. Pay particular attention to the slope and surface finishing requirements of curb ramps. Detectable warnings are typically required to meet ADA requirements, and field adjustments may be needed to meet slope requirements. Review the locations of drainage structures to ensure that no new drainage structures are aligned with curb ramps.

Current as built utilize Survey 123 application, which allows CDOT's inspection staff to record curb ramp as-built measurements on a tablet in the field. This electronic system will help ensure we are building functionally accessible ramps and keep CDOT's curb ramp database accurate in real-time. Measurements that exceed the standard and/or tolerance must have an accompanying Form 464 Design Exception Variance Request and Curb Ramp Variance Support Document that are signed by a Program Engineer in accordance with Procedural Directive 605.1.

Survey 123 application, information and available resources for as built can be found here:

<https://www.codot.gov/business/civilrights/accessibility/ada/documents>

CDOT recognizes that it is not always possible for altered elements, spaces, or facilities to fully comply with new construction requirements because of existing physical constraints. Where existing physical constraints make it impracticable for altered elements, spaces, or facilities to

fully comply with the requirements for new construction, compliance is required to the extent practicable within the scope of the project. Variance support document can be found here:

<https://www.codot.gov/business/civilrights/ada/assets/curb-ramp-variance-support-document-091917-final.pdf/view>

Questions about the curb ramps program, taking measurements, or documentation and resources can be directed to Civil Rights & Business Resource Center at dot_civilrights@state.co.us.

608.2.1.3 Concrete Materials and Equipment

Where concrete will be used for sidewalks and bikeways check that the concrete complies with the specified class and that the mix design has been approved (see Section 601). Check for concrete coloring agents if required for curb ramps. Ensure that the specified sampling and testing requirements are being met. Where reinforcing steel is required, check to ensure that the reinforcement is of the proper type and size (see Section 602). Check the type, number, and condition of equipment that will be used to place, consolidate, finish, and cure concrete. Where forms are used, ensure that they are in good condition and of the proper type and dimension. Where slipforming is used, check the slipforming equipment for acceptability. Ensure that the Contractor has adequate materials on hand to properly cure and, as needed, protect the concrete during cold weather.

608.2.1.4 Bituminous Materials and Equipment

Where bituminous materials will be used for sidewalks and bikeways, check materials for conformance and that, the mix design has been approved. Ensure that the specified sampling and testing requirements are being met. Check the type, number, and condition of equipment that will be used to place and compact the mix. Where it is impractical to use standard paving equipment, ensure that the Contractor's proposed alternative methods have been approved. See Section 401 for additional guidance.

608.2.2 During Construction

608.2.2.1 Concrete Sidewalks and Bikeways

Consider the following guidelines during the construction of concrete sidewalks and bikeways:

1. Forms. Where forms are used, check that they are set to the proper line and elevation with respect to grade stakes and that they are firmly staked into position. Pay particular attention to how forms are set with respect to locations of inlet sections, curb ramps, and driveways, and require adjustments where needed. Ensure that forms are set to accommodate drainage. Prior to placement of concrete, verify that forms are treated with an approved release agent.

2. Reinforcement. Where reinforcing steel is required, check spacing, clearance, and supports for acceptability.
3. Moistening of Subgrade. Ensure that the subgrade has been thoroughly moistened before the placement of concrete.
4. Placement and Consolidation. Check for the proper placement and consolidation of concrete. Where slipforming is used, check that the grade has been trimmed to the correct line, cross-slope, and elevation. Check grade stakes, grade line, and electronic controls for proper adjustment, including locations of inlet sections, curb ramps, and driveways. Regularly check alignment, elevation, and crossslope during slipforming, and ensure that the extruded section conforms to typical section, especially the pan (i.e., spill or catch).
5. Joints. Check that transverse expansion joints and saw cuts are located and constructed properly. Joint types and locations should match those in adjacent concrete. Ensure that approved expansion material is placed to full depth in the joint reservoir. Verify that edging is performed where required. Construction joints shall be formed around all appurtenances, such as manholes and utility poles that extend through the sidewalk.
6. Finishing. Check the acceptability of the surface finish. Pay particular attention to texturing requirements (e.g., curb ramps). The finishing operation ideally should be accomplished without the use of additional water.
7. Curing. Verify that concrete is properly cured for the specified curing period. Where curing compound is used, check that it is of an approved type and that the rate and time of application are acceptable. Ensure that the Contractor complies with the provisions for concrete protection during cold weather.
8. Protection. Verify that the Contractor protects the concrete sidewalks and bikeways for the specified period.
9. Form Removal and Backfill. Form removal and backfill must not be started until the concrete has reached sufficient strength to withstand damage. Ensure the edges are adequately shouldered. Watch for damage to the concrete during the backfill operation.

608.2.2.2 Bituminous Sidewalks and Bikeways

Check the alignment, elevation, depth, and cross-slope of the bed course material and ensure that it has been thoroughly compacted. Verify that the correct mix is being used. Where tack coat is specified, check that a proper type of bituminous material is being applied at the specified rate. Monitor the operation for proper mix placement and ensure that full compaction is being achieved. After construction, check that the edges are adequately shouldered. See Section 401 for additional guidance.

SECTION 609 CURB AND GUTTER

609.1 GENERAL

The treatment of the foundation and forms for curb and gutter systems greatly affects the quality of the final product. Substandard work generally produces curb and gutter systems that promote standing water and deterioration of the roadway structure.

609.2 INSPECTION GUIDELINES

609.2.1 Before Construction

Before construction begins, ensure that the base has been properly prepared (see Section 608.2.1.1). Where concrete curb and gutter is specified, check the concrete class and review Section 608.2.1.3 for additional materials and equipment considerations. Where bituminous curb is specified, verify mix design approval and that the curb machine is of an approved type. Review Section 608.2.1.4 for additional guidance.

609.2.2 During Construction

609.2.2.1 Concrete Curb and Gutter

Check that forms are rigidly braced at the correct line, grade, and depth. Require correction of any weakness found in formwork. Verify that forms have been set correctly to accommodate all drainage per typical section (e.g., pan constructed to spill or catch). Where reinforcement is required, check for proper type and placement. Watch for proper placement and consolidation of concrete. Check joints for proper type and location, including mortared joints where applicable. Check length of sections and finish of joints upon form removal. Verify surface finish and timely application of curing compound.

See Section 608.2.2.1 for additional guidance.

609.2.2.2 Bituminous Curb

Check the location and layout for compliance with the drainage requirements of the Contract. Monitor placement to ensure that the curb machine is forming a uniform and compact curb shape at the correct alignment. Ensure that the proper type and rate of tack are applied in only the area where curb is to be placed. Check for the proper application of a fog coat after the curb is placed. Know if the curb is to receive paint or seal, and check for a clean and dry surface. Verify that temperature requirements are met.

609.2.3 After Construction

Ensure that the Contractor takes adequate precautions to protect concrete from cold weather conditions. Verify that forms are not removed and the backfill operation is not begun until the concrete has gained sufficient strength to prevent damage from the operation. Upon removal

Miscellaneous Construction

of forms, inspect the concrete curb and gutter for honeycombed areas and require proper repair work to be performed.

SECTION 610 MEDIAN COVER MATERIAL

610.1 GENERAL

Median cover material will generally be comprised of a concrete, bituminous, or stone material. The quality of the finished product depends greatly on the attention given to ensuring a properly prepared base. Construction requirements for median cover material are specified in Section 608 of the Standard Specifications.

610.2 INSPECTION GUIDELINES

The inspection guidance provided in Section 608.2 generally applies to concrete and bituminous median cover. In addition, consider the following:

1. **Herbicide Treatment.** Prior to herbicide treatment, ensure that the Region Maintenance Noxious Weed Coordinator has been notified of the location and time of application. See Section 217.2 for additional guidance on herbicide treatment.
2. **Pattern and Color.** Check for the correct pattern and color of application.
3. **Stone Material.** Check for the correct type, size, and depth of stone material.
4. **Plastic Sheeting.** Where plastic sheeting is required, verify it is of the correct type and thickness.
5. **Expansion Joint Material.** Ensure placement is in accordance with the Contract.

SECTION 611 CATTLE GUARDS

611.1 GENERAL

Cattle guards may be either precast or cast-in-place. The Contract will designate the location and type to be constructed. Each cattle guard must be constructed in accordance with the details shown in the Contract.

611.2 INSPECTION GUIDELINES

Cattle guards must be carefully constructed to the specified grade and cross-slope to provide a smooth riding surface and a well-drained facility. Ensure that bumps, ponding, and other errors in elevation are properly corrected. Consider the following guidelines:

1. **Material Certification.** Ensure that all required material certifications have been obtained and that they reflect proper materials.
2. **Concrete Foundation.** Ensure that the concrete foundation is placed, finished, and cured in accordance with the requirements of Section 601 of the Standard Specifications. See Section 601 for additional guidance.
3. **Wings.** Timber and steel materials that are used in wings of cattle guards must conform to the respective requirements of Section 508 and Section 509 of the Standard Specifications. Ensure that timber posts are the correct size and treated in accordance with specified requirements. Check steel for proper welding and painting.
4. **Backfill.** Ensure that backfill material is properly placed and compacted to the correct grade and cross-slope.

SECTION 612 DELINEATORS AND REFLECTORS

612.1 GENERAL

Delineators and reflectors are supplemental traffic control devices that delineate the alignment of the roadway during hours of darkness and inclement weather. Delineators and reflectors are especially advantageous during inclement weather because they remain visible where the road is wet or covered with snow. Installation must always conform to Contract requirements.

612.2 INSPECTION GUIDELINES

612.2.1 Before Construction

Before delineators and reflectors are installed, consider the following:

1. Delineators. Know the type and color of delineators required, and ensure compliance with specified requirements.
2. Reflectors. Check reflectors for guardrail and concrete barrier for compliance with respect to type, color, and dimension. Verify that containers are marked with the CDOT pre-inspection stamp or that samples have been submitted to the Materials and Geotechnical Branch and found acceptable.
3. Condition. Inspect delineator and reflector materials for damage and reject as necessary.

612.2.2 During Construction

Consider the following guidelines during installation of delineators and reflectors:

1. Location and Spacing. Verify that delineators and reflectors are being laid out and installed at the correct location and spacing, especially with regard to curves and roadside obstacles. The Contract will generally designate spacing criteria in a tabular format.
2. Delineators. Delineator posts may be driven or set in drilled holes. Check for damage during installation, and ensure that posts are set stable and plumb. Check mounting height and lateral clearance for acceptability. Angular placement shall be according to Standard Plan S-612-1. Ensure that the proper number and color of reflectors are affixed to each delineator post.
3. Base Anchoring. Ensure the anchoring depth can be achieved. If the minimum anchor depth cannot be obtained, the anchor shall be embedded in concrete.
4. Reflectors. Verify that reflectors are properly mounted on guardrail and concrete barriers. Check the location and mounting height for acceptability. Ensure that the

proper number and color of reflectors are installed. Pay particular attention to the direction and orientation of reflectors during installation.

SECTION 613 LIGHTING

613.1 GENERAL

The materials and construction requirements for lighting will be governed by the Contract and Section 613 of the Standard Specifications.

613.2 INSPECTION GUIDELINES

613.2.1 Before Construction

Before lighting work begins, consider the following:

1. **Preconstruction Conference.** If a lighting plan is included in the Contract, the Contractor is required to supply at the Preconstruction Conference a list of all material and equipment to be incorporated in the work. The Contractor must coordinate with the local utility company to ensure system compatibility and to plan for required utility connections and any needed utility relocations or adjustments.
2. **Materials Considerations.** Check the type, dimension, coating, and condition of all lighting materials including light poles, arms, luminaires, galvanized fastener hardware, breakaway bases, conduits, cables, pull boxes, and expansion fittings. Ensure that required material certifications have been submitted.
3. **Screw-In Foundations.** If screw-in foundations will be used, ensure that the required Soil Test Reports have been received from the Contractor and found acceptable. Screw-in foundations are permitted only for specific soil conditions. Check to ensure that all material certifications have been submitted. Know the manufacturer's recommended installation procedures.
4. **Concrete Foundations.** Where concrete foundations will be used, they may be either precast or cast-in-place. Check concrete materials for conformance. Check that foundation locations and dimensions conform to designated requirements, and ensure that a solid and properly compacted foundation subgrade is provided. See Section 503 for additional guidance.
5. **Layout and Obstructions.** Review the general layout of the work for acceptability, and verify that the Contractor has accounted for underground obstructions and overhead lines (e.g., power, telephone, cable television).
6. **Conduit and Cable.** The location of conduit runs will be established during construction with consideration to existing and future installations. Know the requirements for conduit placed under roadway sections. Know circumstances that require pull boxes (e.g., wire splices, conduit ends and angles). Know if jacking of conduit is required.

613.2.2 During Construction

Consider the following guidelines during the installation of highway lighting:

1. **Screw-In Foundations.** Where screw-in foundations are permitted, verify that the Contractor is following the manufacturer's recommended installation procedures.
2. **Concrete Foundations.** Where concrete foundations are used, ensure that they are properly poured or placed. Pay particular attention to reinforcement, curing, and backfill requirements.
3. **Light Poles.** Ensure that the Contractor installs light poles and luminaires in accordance with specified requirements and the manufacturer's installation guidelines. Check that light poles are set plumb at the correct location. Verify the proper installation and location of breakaway bases. Require that any coating damage is properly repaired.
4. **Pull Boxes.** Verify that pull boxes are being installed at the correct location and at the proper grade.
5. **Trenches.** Check trench depth and shape for compliance. Watch for obstructions. Ensure that the correct material and procedures are being employed for the backfill operation.
6. **Jacking.** Check the clearance from roadway of jacking pits to ensure the specified minimum is not encroached. Do not permit the use of water to aid jacking.
7. **Expansion Fittings.** Check that conduit expansion fittings are properly installed on bridges.

613.2.3 After Construction

Check backfilled trenches for settlement and the correct operation of lights at night prior to project acceptance. Check for tagging of all electrical conductors in boxes. Check that a plastic envelope containing the cabinet drawings, line diagram, luminaire schedule and list of all system components is mounted to the inside of the lighting cabinet door.

SECTION 614 TRAFFIC CONTROL DEVICES

614.1 GENERAL

Traffic control devices must be installed in compliance with the requirements of the Contract. Contact the Region Traffic Engineer for any needed assistance. See Section 630 for guidance on temporary traffic control in construction zones.

614.2 HIGHWAY SIGNS

614.2.1 Before Construction

Before the installation of highway signs, consider the following guidelines:

1. Class III/Special Signs. Verify that the detailed layouts for Class III and special signs have been furnished to the Contractor.
2. Material Certifications. Verify that material certifications have been received.
3. Permanent Barricades. Verify if permanent barricades are required.
4. Timber Posts. Prior to installation, inspect timber posts for acceptability. Check the certified grading stamp on the posts for proper inspection agency, species, and grade (see Grade Stamps of Accredited Lumber Agencies in Appendix D).
5. Steel Posts. Check steel post certifications, welding, and coating for acceptability.
6. Hardware. Inspect fastening hardware prior to installation. Verify that bolt heads and washers match the background color of panels and legends, as appropriate. Check that anchor bolts and washers are galvanized.
7. Sign Location. Inspect staked sign locations for compliance to the Contract. Check for obstructions to sign visibility. When inspecting sign staking, consider placing signs behind guardrail where appropriate.
8. Sign Panels. Check for closure strip on vertical seams. Verify that the back side of all panels is stamp dated. Verify if masking of sign legends is required.

614.2.2 During Construction

Verify that highway signs are installed in accordance with the Contract and the Manual of Uniform Traffic Control Devices. Ensure that removal and installation of signs follow a logical sequence to maintain traffic safety.

614.2.2.1 Post Installation

Consider the following guidelines during highway sign post installation:

1. Footings. Ensure that concrete, reinforcing steel, and backfill for footings conform to specified requirements.
2. Posts. Check for correct type and size of posts. Verify if modifications to existing posts are required.
3. Plate Bolts. Check torque on breakaway plate bolts and fuse plate bolts.
4. Breakaway Assembly. Check ground level with reference to the top of the footing. Clearance of the breakaway assembly is critical. Check breakaway holes for spacing and diameter on six inch by six-inch timber posts.
5. Vertical Alignment. Ensure that all posts are plumb.
6. Post Embedment. Verify that post embedment is proper for the post size.

614.2.2.2 Sign Panels

Consider the following guidelines during sign panel installation:

1. Illumination. Verify if sign illumination is required.
2. Sign Panels. Check for correct type and size of panels. Verify if modifications to existing sign legends are required. Inspect for cleanliness and general appearance.
3. Angular Placement. Inspect the angle of sign placement to the roadway for compliance.
4. Height and Clearance. Check for proper height above edge of traveled way and proper vertical and horizontal clearance of sign panel.

614.3 OVERHEAD SIGN STRUCTURES

614.3.1 General Considerations

Overhead sign structures have a substructure component constructed of reinforced concrete, and a superstructure component typically constructed of structural steel. In most cases, the substructure is a drilled caisson with anchor bolts that project from the top of the foundation to connect with the superstructure. Drilled caissons are designed to provide support for the overhead sign from structurally stable soil. It is essential that the anchor bolts are accurately located, have the proper orientation, and project the specified length from the top of the foundation. It is important to examine the proposed overhead sign location for acceptability and inspect the soil conditions to ensure they are as described in the Caisson Drilling and Installation Notes in the Contract.

614.3.2 Shop Drawings/Fabrication Inspection

Shop drawings are required for sign structures. The Project Engineer will send the drawings to the Staff Bridge Branch according to Section 105.2.3. Upon receipt of the drawings, the Staff

Bridge Branch will forward them to the Project Structural Engineer for review. Once reviewed and accepted, the drawings will be returned to the Staff Bridge Branch for distribution to the Fabrication Inspector and Project Engineer. Because the Fabrication Inspectors only perform random inspections, upon receipt of the reviewed drawings, the Project Engineer will perform a thorough field inspection of the fabricated structure and report the fabrication's acceptability on CDOT Form 157 - Field Report for Sample Identification or Materials Documentation. The Project Inspector must have a thorough understanding of shop drawings, and the drawings must be readily accessible at all times. Whenever the Contractor is working, the Project Inspector should actively monitor erection and assembly to ensure compliance and immediately report significant problems. Significant problems warrant stoppage of work until the structure's design engineer can review the situation and evaluate solutions. Disassembly may be necessary.

614.3.3 Substructure Considerations

Before construction, ensure that the ground surrounding the substructure is well drained and that the overhead sign will have a minimum vertical clearance required above the finished roadway surface. The inspection guidance provided in Section 614.4.3 for traffic signal substructures is also applicable to overhead sign substructures. Consider the following additional guidelines:

1. **Anchor Bolts.** Ensure that anchor bolts are accurately located, have the proper orientation, and project above the top of the drilled caisson concrete the specified length. For bridge type overhead signs, verify that anchor bolts are placed such that the distance between drilled caissons, as referenced between the centerline of anchor bolt groups, complies with that specified on the shop drawings.
2. **As-Constructed Survey.** The Contractor is required to perform an As-Constructed Survey of the substructure as soon as practical after it has been completed. The requirements for the As-Constructed Survey are defined in the notes on the plan sheets for the overhead sign.

614.3.4 Superstructure Considerations

Bolted connections are used to connect the superstructure to the substructure and to fasten structural elements within the superstructure itself. Bolts must be tightened as specified without gaps between connection plates and without overtightening. Consider the following during erection of overhead sign structures:

1. **Bolt Tightening.** Verify that bolts in field splices are tightened in an incremental and progressive manner. This must be performed while the splice connections are not carrying load. To create this no-load condition, a crane will be necessary to lift fabricated components during tightening.
2. **Overtightening.** Do not permit the overtightening of bolts to close non-designated gaps or where such action will distort steel components.
3. **Adjustment and Leveling.** Once erected, the anchor nuts and leveling nuts may require adjustment to level the sign. When assessing the need for leveling, no external support

should be attached to the superstructure; however, during adjustment, a crane will be necessary to lift the superstructure. Verify that the leveling nuts are in contact with the base plate before releasing the overhead sign from the crane and tightening the anchor nuts.

4. Field Welding. Unless otherwise designated, field welding is not permitted.

614.4 TRAFFIC SIGNAL SYSTEMS

614.4.1 General Considerations

The supports for traffic signals have a substructure component constructed of concrete, a superstructure component constructed of structural steel, and an electrical system component. The substructure is designed to provide support from structurally stable soil. It is important to examine the proposed location for acceptability and inspect the soil conditions to ensure they are as described in the notes in the Contract. The following types of support systems are typically installed for traffic signals:

1. Span Wire. In span-wire installations, the strain pole is typically placed in a drilled hole, and concrete is poured around the pole for support. Span wire is then strung between the poles once the concrete has hardened.
2. Mast Arm. In mast-arm installations, the substructure is typically a drilled caisson with anchor bolts projecting from the top of the caisson. It is essential that the anchor bolts are accurately located, have the proper orientation, and project from the top of the caisson the specified length. The pole of the superstructure is connected to the anchor bolts of the substructure using bolted connections. Bolted connections are also used to connect the mast arm to the pole of the superstructure. It is important that all bolts be tightened as specified without overtightening and without gaps or spaces between connection plates.

614.4.2 Shop/Working Drawings

The type of drawing submittal necessary is specified on the traffic signal plan sheets.

614.4.3 Substructure Considerations

614.4.3.1 Before Construction

Thoroughly review the Contract and consider the following before construction of the substructure begins:

1. Soil. Verify that the soil surrounding the substructure location is well drained. Bogs and sloughs are undesirable locations, especially where the lower portion of the superstructure will be in a wet or frequently moist environment. Prompt notification is required if such conditions are found to ensure that the design engineer can consider alternatives to resolve the problem.

2. Vertical Clearance. Verify that the proposed location will accommodate the minimum required vertical clearance above the roadway surface. Provide immediate notification if encroached, because the design engineer will need to evaluate alternatives such as relocating the substructure or raising its elevation.
3. Survey References. Verify that the Contractor has established adequate survey referencing to locate the center of the bolt circle and pole. Multiple survey reference points are preferred.
4. Utilities. Verify that the Contractor has staked known utility locations, resolved utility conflicts, and coordinated any needed adjustments or relocations.

614.4.3.2 During Construction

Section 503 provides inspection guidance that is applicable to the construction of traffic signal substructures. Consider the following additional guidelines:

1. Drilling Auger. Check the auger diameter used for boring the foundation hole for acceptability.
2. Drilling Operation. During the drilling operation, inspect the soils and provide immediate notification of any discrepancies with the soil notes in the Contract so that the design engineer can assess the situation and consider any needed alternatives. Check the depth of the hole of compliance, and verify that all loose material is removed. On span-wire installations, ensure that crushed rock is placed in the bottom of the hole as specified.
3. Reinforcing Steel. Verify that the reinforcing steel complies with the requirements of Section 602 of the Standard Specifications. Check bar arrangement and spacing for compliance. Do not permit the welding of reinforcing steel.
4. Concrete Placement. Verify that concrete material and placement, respectively, complies with the requirements of Section 601 and subsection 503.07 of the Standard Specifications.
5. Anchor Bolts. Verify that anchor bolts are accurately located, have the proper orientation, and project above the top of the drilled caisson concrete the specified length. Do not permit the welding of any attachments to anchor bolts.
6. Concrete Curing. Ensure that the concrete at the top of the drilled caisson is cured in accordance with subsection 601.13 of the Standard Specifications.
7. Cover Plate. Ensure cover plates are installed when the pole is erected to prevent intrusion by wildlife.

614.4.4 Superstructure Considerations

614.4.4.1 Span-Wire Installations

For span-wire installations, ensure that the strain pole and span wire are installed in compliance with the Contract. The span wire should not have more than a five percent sag after loading. Upon completion, ensure that the Contractor furnishes the requisite As-Constructed Plans.

614.4.4.2 Mast-Arm Installations

Bolted connections are used to connect the pole to the substructure and to connect the mast arm to the traffic signal pole. Bolts must be tightened as specified without gaps between connection plates and without overtightening. To ensure adequate vertical clearance, the traffic signal pole must be placed such that it is plumb when deflected by the load it carries. Verify that the leveling nuts are in contact with the base plate before the anchor bolt nuts are tightened, and ensure that anchor nuts and leveling nuts are tightened according to the notes in the Contract (see Section 614.3.4). Upon completion, verify that the Contractor furnished the required As-Constructed Plans.

614.4.5 Electrical Considerations

614.4.5.1 Before Construction

Verify that all Certificates of Compliance for materials have been received and checked and that the Contractor has furnished the required list of materials and equipment and schematic wiring diagram. Where applicable, verify that provisions have been met to properly coordinate new traffic signals with existing systems.

614.4.5.2 During Construction

The Region Traffic Engineer may be contacted for inspection assistance. During electrical work traffic signal systems, consider the following:

1. **Conductors.** Verify that the correct number of active and spare conductors has been provided. Ensure that the end of each run is taped until connected. Do not permit the splicing of conductors outside of specified areas (e.g., pull boxes, handhole locations).
2. **Wire Slack.** Verify that the proper slack is provided at pull boxes and handhole locations.
3. **Control Cable.** Check that the control cable is properly tagged and identified and that its ends are taped until connected. In span-wire installations, verify that the control cable is properly attached to the span wire by cable rings spaced a maximum of one foot apart. There should be no sag in the control cable.
4. **Vehicle Detector Loops.** Verify that vehicle detector loops are of the proper type and are installed in conformance with the requirements of the Contract. Check the depth of the detector for compliance and verify that saw cuts are properly filled after installation.

5. Pull Wire. Verify that pull wire has been placed in all new conduit and in existing conduits, if cable is added or replaced. Ensure that there is a minimum of two feet of pull wire doubled back at each termination.
6. Bonding and Grounding. Verify that all bonding and grounding comply with Article 250 of the National Electrical Code.
7. Controller Cabinet. Verify that the controller cabinet is of the proper type and ensure that it is mounted to provide a clear view of the intersection when the cabinet door is open.
8. Pre-emption Equipment. Verify the proper location and installation of any required pre-emption equipment for emergency pre-emption or railroad coordination.
9. Signal Heads. Verify that traffic signal heads, pedestrian signal heads, and pushbuttons are of the proper type and installed in compliance with the Contract. Pay particular attention to mounting height and orientation with respect to driver and pedestrian approaches. Verify that signal heads are covered until the system is operational.
10. Signal Lamps. Verify that the traffic signal lamps are of the proper type and wattage.

614.4.5.3 After Construction

Consider the following after the installation of traffic signal systems:

1. Backfilling and Patching. Where required, verify that trenches are properly backfilled and the roadway surface is properly patched.
2. As-Constructed Plans. Verify that the Contractor has furnished the required As Constructed Plans.
3. Testing. Before accepting the system, ensure the Contractor performs a five-day functional test and that any needed adjustments are performed.
4. Diagrams. Verify that the controller diagram and intersection-phase diagram are placed inside the controller cabinet.
5. Manufacturer Guarantee. Verify that the Contractor has furnished the manufacturer guarantee for the signal equipment.
6. Local Agency. Where applicable, verify that the Local Agency has been notified to accept operation of the signal system.
7. Cleanup. Verify that the area is left in an acceptable manner and know the disposition of any material or equipment removed from the job site.

SECTION 615 WATER CONTROL DEVICES

615.1 GENERAL

The construction of water control devices is discussed in Section 603 of the Standard Specifications. Erosion control devices (e.g., Embankment Protector Type 3 and Type 5) are generally constructed with materials such as dry or grouted rubble, concrete, bituminous, riprap, and geotextile fabric, as discussed in their respective Sections of the Standard Specifications. The material is placed on the embankment as an apron for protection against water runoff.

615.2 INSPECTION GUIDELINES

Inspection guidelines for water control and erosion control devices are presented in the Section of the Manual for which the material applies. Consider the following additional guidelines:

1. Slide Head gates and Automatic Drain Gates. Check for correct sizes and verify that the gates have been approved for use. Check for proper coating.
2. Embankment Protectors. Check that embankment protectors are located according to the Contract and cover an area sufficient to provide adequate runoff protection. Verify if curbing is required.

SECTION 616 SIPHONS

616.1 GENERAL

Siphons are generally used in conjunction with irrigation systems where it is necessary to pipe water from one side of the roadway to the other and where the ditch line is higher than the elevation of the roadway to be crossed. To provide sufficient cover material over the pipe, a siphon is used.

616.2 INSPECTION GUIDELINES

616.2.1 Before Construction

Upon delivery, inspect all materials for damage. Verify items such as pipe and valves are of the proper type and size. Ensure that any required material certifications have been obtained.

616.2.2 During Construction

Watch for damage to materials (e.g., crushing of pipe) during installation and consider the following:

1. Grade. Check for reversed siphon grade.
2. Drain Valves. Verify the proper installation of drain valves and ensure that they are accessible after installation.
3. Drainage. Proper provision for drained water to escape is required.
4. Trash Guards. Where required, verify the proper installation of trash guards and ensure that the specified coating is properly applied.
5. Watertight Test. Test for a watertight installation before backfilling.

616.2.3 After Construction

Prior to acceptance, inspect siphons for proper operation.

SECTION 617 RESERVED

SECTION 618 PRESTRESSED CONCRETE

618.1 GENERAL

Prestressed concrete members differ from conventionally reinforced concrete members in that the concrete member is stressed prior to loading. This pre-compression is achieved through the action of high-strength steel bars or stranded wire that are placed within the structural members. Prestressed concrete members are used to minimize tension in structural elements, thus allowing the use of minimum concrete material.

Prior to fabrication of prestressed members, contact the Staff Bridge Fabrication Inspection Unit (303) 757-9339.

See specification Section 618 for pre erection requirements and see Appendix A for the pre-erection conference agenda.

618.1.1 Pre-tensioning / Post-tensioning

The prestressing force may be applied before the concrete is placed or after the concrete has cured. Consider the following:

1. Pre-tensioning. Pre-tensioning is the method of applying the prestressing force before placing the concrete. The bars or wire strands are anchored by a continuous bond throughout the length of the structural element, unless debonded.
2. Post-tensioning. Post-tensioning is the method of applying the prestressing force after the concrete has cured. In post-tensioning, the bars or wire strands are mechanically anchored at each end of the member.

618.1.2 Creep and Camber

Creep is the shortening of a girder after it is prestressed. The actual shortening is slight and occurs rapidly, tapering off over a period of about two months. Because the prestressing force is applied eccentrically, a noticeable uplift, or camber, will occur, which is anticipated during design. However, if the girder cambers beyond tolerable limits, corrective action will be necessary.

618.1.3 Precast Girders

Precast girders are fabricated on a flat surface at the precast yard and shipped to the bridge site for erection similar to steel girders. The girders will camber when the prestressing force is applied (see Section 618.1.2). Be aware that girder age and storage conditions can produce additional camber that may render the girder unacceptable.

618.1.4 Cast-In-Place Girders

Concrete box and “T” girders are typically cast-in-place and post-tensioned in the field. During construction, galvanized rigid ducts are cast into the girder webs. Once cured, the wire strands are pulled through the ducts to prestress the member. Because these girders are produced in the field, the forms and falsework must account for deflections due to dead load and prestressing.

618.1.5 Segmental Construction

The use of precast or cast-in-place post-tensioned segmental structures is generally limited in application to side hill bridges and viaducts. Such structures are generally long in span with limited access area, thus requiring gantries or heavy cranes for construction and erection. Bars, wire strands, or a combination of both may be used to impart the prestressing force in segmental members.

In precast applications, the members are match cast to produce a bridge that conforms to the required geometry, but the prestressing is performed in the field. Contrary to conventional girders, segmental members must accommodate both heavy construction and final service loads, and special construction techniques are employed to provide stability. It is therefore important to thoroughly study the Contract and the fabrication drawings. If the Contract designates the prestressing force required only for the final service load, the fabrication drawings must define that force needed to accommodate both construction and service loads. Note that superstructure camber has already been developed in member segments during match casting but may be adjusted between segments with shims during erection.

618.2 INSPECTION GUIDELINES

618.2.1 Precast Girders

Inspection work is to be performed by Fabrication Inspectors from the Staff Bridge Branch. Maintain a close liaison with Fabrication Inspectors to coordinate delivery and follow through on any repair work prior to final acceptance of the girders.

618.2.1.1 Before Construction

Before precast girder construction begins, thoroughly review the Contract, shop drawings, and job safety requirements. Consider the following:

1. Construction Procedures. Review the prestressing procedures with the Contractor. Check the Contractor's field sheets for compliance. Pay particular attention to strand elongation and tiedown details.
2. Concrete Mix. Verify acceptability and approval of the aggregate source and concrete mix design.

618.2.1.2 During Construction

Consider the following during precast girder construction:

1. Reinforcement/Embedments. Inspect reinforcing cages and embedments for proper assembly and placement in forms.
2. Forms and Prestressing Steel. Inspect forms and prestressing steel for cleanliness and proper dimensions. Observe the tensioning procedure and verify compliance with the shop drawings.
3. Concrete Placement. Inspect concrete placement, form vibration, and curing method for acceptability.
4. Tensioning. Ensure that the concrete has attained the proper strength prior to tensioning.

618.2.1.3 After Construction

To maintain the integrity of the final product, it is important that the precast girders be properly handled and stored. If the girders are tipped or dropped, they may split apart or become otherwise damaged. After precast girder construction, consider the following:

1. Shipping/Erection. Review the methods of shipping and erecting the girders with the Contractor. A Pre-erection conference will be held prior to installation; erection agenda is in Appendix A.
2. Camber. Check the camber in the girders. Excessive camber may cause the girder flange to project into the deck slab, interfering with the concrete deck panel or placement of reinforcing steel. Notify the Staff Bridge Branch immediately in such situations.

618.2.2 Cast-In-Place Girders

Coordinate with the Materials and Geotechnical Branch for the QA testing of materials used for cast-in-place girders. The Project Engineer and Project Inspectors are responsible for the inspection of all girder construction in the field.

618.2.2.1 Before Construction

Before cast-in-place girder construction begins, thoroughly review the Contract, shop drawings, and job safety requirements. Pay particular attention to the blockout dimensions and anchorage clearances noted on the shop drawings. Consider the following additional guidelines:

1. Prestressing Construction Procedures. Review the prestressing procedures with the Contractor and become familiar with the equipment and materials to be used. The Staff Bridge Branch will provide assistance for personnel unfamiliar with posttensioning.

2. Concrete Mix. Verify acceptability and approval of the aggregate source and concrete mix design.
3. Prestress Strand Sample. Obtain samples of the wire strand material that will be used for prestressing well in advance of the post-tensioning operation. Forward the sample to the Materials and Geotechnical Branch for testing.

618.2.2.2 During Construction

Consider the following during cast-in-place girder construction:

1. Forms. Inspect forms for cleanliness and proper dimensions.
2. Grouting Ports and Vents. Verify that grouting ports and vents will remain accessible after concrete placement.
3. Concrete Placement. Ensure that concrete placement complies with specified requirements. Check for proper vibration of concrete around and under anchorages to eliminate voids.
4. Ducts. Verify that ducts are blown clear immediately after the concrete is placed. Ensure ducts and/or tendons are installed at the proper locations and without any wobble.
5. Prestressing Steel. Ensure that exposed prestressing steel is protected from dirt and debris when threaded through ducts in the field. If not immediately tensioned, also ensure that it is adequately protected from adverse weather conditions.
6. Construction Joints/Anchorage Zones. Construction joints should be located well away from anchorage zones and anchorage zone reinforcement. Verify that all anchorage zone reinforcement is placed in accordance with the Contract and shop drawings and reviewed by the Project Structural Engineer.
7. Concrete Curing. Check the curing of concrete for compliance, and ensure that the concrete attains proper strength prior to starting the prestressing operation.

618.2.2.3 During Prestressing

Review the sequence of operations with the Contractor, and be concerned with safety. Stay away from the backside of the ram, dead-end anchorages, and above the anchorage during the prestressing operation. The prestressing operation will elongate the steel strands in the members as the jacking force is applied. The jacking force is applied by a ram that is equipped with a dial gauge, graduated in pounds per square inch. This dial gauge is used to indirectly monitor the amount of jacking force applied. A calibration curve is provided with the dial gauge, which is calibrated for the ram. Use this curve to convert the jacking force (e.g., P(JACK)) to an associated reading on the dial gauge. Monitor strand elongation as follows:

1. Find the strand elongation length on the shop drawings. The actual stand elongation will vary from what has been calculated if the physical properties of the strand are different from those assumed in the calculations. The following equation is used as a basis to adjust the strand elongation:

$$e = PL/(AE)$$

where:

e = strand elongation (inches) P = force applied to the strand (kips)

L = length of strand (inches)

A = area of the strand (square inches)

E = Modulus of Elasticity of the steel strand (kips/ksi)

Moving P and L to the other side of the equation, the expression becomes:

$$PL = eAE.$$

The subscript 1 is added to the right side of the equation to denote the assumed strand physical properties and becomes:

$$P1L1 = e1A1E1.$$

Similarly, in a second equation, the subscript 2 is added to denote the actual strand physical properties and the equation becomes:

$$P2L2 = e2A2E2.$$

Since P1L1 equals P2L2 the two equations can be set equal to each other:

$$e1A1E1 = e2A2E2.$$

Solving for e2 yields:

$$e2 = e1A1E1/A2E2$$

A1 = 0.153 square inches for 0.5 inch strand and A1 = 0.217 square inches for 0.6 inch strand. The shop drawings will show the size and strand area assumed. The value assumed for E1 will also be shown on the shop drawings. The values for A2 and E2 will be reported on samples from each heat of strand submitted to the Materials and Geotechnical Branch for testing.

2. Before the Strand Elongation is measured, the strand is usually jacked to 20 percent of P(JACK). This is done to remove slack in the strands. The measured strand elongation is reduced by the same percentage (20 percent).

3. Measure the strand elongation as follows:

Mark a strand in a tendon 10 inches from the end of the ram (find a part of the ram that does not move as the reference point and measure from there). A permanent black felt tip marker can be used to make the mark. Monitor the dial gauge reading as the jacking force approaches P(JACK).

At P(JACK), measure the distance to the mark made on the strand from the reference point. This distance, less the dead end anchor set, should be equal to or greater than the strand elongation calculated in Step 2 above. If the elongation is not what is expected, carefully check the calculations and measurements to verify that the strand elongation is in fact short.

If the measured strand elongation varies more than seven percent from the calculated strand elongation or if the elongation measurements are erratic, examine the prestressing operation for possible problems. If the problem cannot be solved in the field, contact the Project Structural Engineer or the Staff Bridge Branch for assistance. Do not permit the protruding strands to be cut until the strand elongation has been verified and all problems have been properly addressed.

618.2.2.4 After Prestressing

Check that tendons are grouted as soon as practical after prestressing. All grouting ports and vents must be operating properly to ensure full-length grouting. The prestressing and grouting for all tendons in a particular bridge must be completed before the work is accepted.

618.2.3 Segmental Construction

In advance of segment casting, discuss the inspection requirements for segmental structures with the Fabrication Inspectors from the Staff Bridge Branch (303) 757-9339. The Project Engineer and Project Inspectors are responsible for the inspection of all erection and/or site fabrication.

618.2.3.1 Before Construction

Before segmental construction begins, thoroughly review the Contract, shop drawings, and job safety requirements. Pay particular attention to the blockout dimensions and anchorage clearances noted on the shop drawings. Check gantry drawings and precast form drawings to ensure they will accommodate variables due to roadway curvature, tapered webs, and slabs within the elements. Consider the following additional guidelines:

1. Construction Methods. Review the prestressing procedures and erection sequence with the Contractor. Verify that equipment is available to transport and erect the segments. Become familiar with all equipment, forms, and other items involved in the fabrication and prestressing of the bridge.
2. Concrete Mix. Verify acceptability and approval of the aggregate source, concrete mix design, epoxy bonding agents, and other materials used in the work.

3. Inspection Scheduling. Coordinate the inspection schedule with the casting and erection sequence that has been established by the Contractor.

618.2.3.2 During Construction

Be concerned with safety. Stay away from the back of jacks during the prestressing operation. Periodically check work platforms, gantries, and highlines for safe operation. Consider the following additional guidelines:

1. Forms. Inspect forms for cleanliness and proper alignment and dimensions.
2. Concrete Placement. Verify concrete placement for compliance and ensure that the concrete is properly vibrated.
3. Ducts. Verify that ducts are blown clear immediately after concrete is placed. Check duct and/or tendon installation for proper location and stability (i.e., no wobble). Check ducts for leakage and verify that any repair work will withstand the forces imparted by concrete placement and vibration.
4. Prestressing Steel. Verify that the Contractor protects the prestressing steel from corrosion and damage prior to prestressing and grouting.
5. Concrete Curing. Ensure that the concrete has attained proper strength prior to beginning the prestressing operation.
6. Strand Elongation. Check ram gauge readings and strand elongation as described in Section 618.2.2.3. Because of the highly mechanized casting operation of segmental construction, automatic procedures may need to be established to record readings for documentation purposes.
7. Grouting. Verify that tendons are grouted in accordance with the shop drawings.
8. Epoxy Joint Material. Inspect the mixing of epoxy joint material and its application to ensure complete coverage and proper curing.
9. Segment Alignment. Check the segments for proper line and grade as they are erected. Checkpoint elevations on a particular segment will vary as additional segments are added; however, tabulated data will be made available by the Contractor to recheck points as the construction progresses. If alignment begins to deviate from the tabulated data, verify that the alignment is properly corrected.

618.2.3.3 After Construction

The stressing and grouting of tendons in the bridge must be completed before the work is accepted. Inspect the final structure to verify that all temporary supports have been removed, all chipped corners, tie rod holes, etc., and have been patched and that bearings and expansion devices are functioning properly.

SECTION 619 WATER LINES

619.1 GENERAL

If work on water lines will be performed by the Contractor under Item 619, the local utility company shall be contacted to ensure that the installation complies with local standards and specifications.

619.2 INSPECTION GUIDELINES

619.2.1 Before Construction

Before construction, inspect the acceptability of all materials to be used in the work. Verify that required material certifications have been received.

619.2.2 During Construction

Review the safety requirements for trenching operations and verify compliance. Regularly check the depth and width of trenches for uniformity and conformance to designated dimensions. Consider the following:

1. Pipe Support. Ensure that the pipe is uniformly supported throughout its entire length.
2. Joints. Verify that joints are constructed in an approved and acceptable manner.
3. Alignment. Alignment must be true. Alignment deviation is limited to plus or minus 0.3 foot per 100 feet.
4. Kickers. Ensure that kickers are used and properly placed to reinforce sharp bends.
5. Watertight Test. Prior to backfilling, test to ensure that the lines are watertight.
6. Backfill. Ensure that backfill is placed in uniform lifts of the specified thickness and thoroughly compacted.

619.2.3 After Construction

Prior to acceptance, inspect water lines for proper operation. As needed, coordinate inspection with the local utility company.

SECTION 620 FIELD FACILITIES

620.1 GENERAL

The Contractor is required to furnish field offices, sanitary facilities, and field laboratories, as designated in the Contract or as otherwise directed. These facilities will be maintained operational by the Contractor during construction and subsequently removed upon completion of the project or as otherwise directed by the Project Engineer.

620.1.1 Trailer Shortages

If field facilities cannot be furnished as specified, the Contractor should immediately notify the Project Engineer so that alternatives can be considered (e.g., use of larger trailers, reconfiguring trailer interiors, use of building facilities). The Project Engineer is responsible for evaluating the acceptability of alternate field facilities. Although the selected alternative should satisfy the intended function of the specified facility, it is important to remain flexible and reasonable in working with the Contractor. Price reductions, if warranted, should be applied judiciously based on the extent of deviation from the intended functionality. Alternate field facilities should be considered on a project-by-project basis and such considerations must not establish a convenient precedent for unreasonably deviating from specified requirements on future projects. The Area Engineer in the Contracts & Market Analysis Branch may be contacted for guidance.

620.2 INSPECTION GUIDELINES

Note and document the date of arrival of all field facilities on the project. Check that the facility dimensions and furnishings conform to the requirements specified in the Contract. Verify that the facilities are serviced by the Contractor and maintained in a satisfactory condition. Document on Form 105 - Speed Memo the date and condition of the facility when removed from the project.

SECTION 621 RESERVED

SECTION 622 REST AREAS AND BUILDINGS

622.1 GENERAL

The material and construction requirements for rest areas and buildings are detailed in Section 622 of the Standard Specifications. The Contractor is responsible for all required permits, pre-inspections, and final inspections in accordance with governing Federal, State, and local laws and ordinances.

622.2 INSPECTION GUIDELINES

Inspection of building, heating, plumbing, sanitary, and electrical installations must be performed by qualified building inspectors charged with these duties. The Notice Of Compliance achieved in the design phase for buildings will list the individuals who are required to perform the inspections for the building work. This will not be a list of CDOT employees or consultants, but rather it will be a list of non-CDOT government agency inspectors and other such certified inspectors. CDOT's inspectors should perform their own inspections in conjunction with the certified building inspectors as outlined below.

622.2.1 Underground Pipe

622.2.1.1 General Considerations

For underground pipe installations, see Section 603 and consider the following general guidelines:

1. Existing Utilities. Watch for conflicts with existing utilities and systems.
2. Trench. Check the pitch, line, and grade of the trench or bed before the pipe is placed and after completion of each pipe section.
3. Pipe Installation. Ensure that the pipe is installed in accordance with the manufacturer's installation recommendations, and consider the following:
 - a. Pipe Cleanliness. Check for cleanliness of pipe sections and joints during placement and after completion. Pay particular attention to the cleanliness of joints.
 - b. Pipe Base. Pipe should be placed on a uniform, firm, and stable base.
 - c. Obstructions. Check for pipe plugs, debris, and other obstructions in the pipe.

622.2.1.2 Water Lines

For water lines, see Section 619 and consider the following guidelines:

1. **Grade Lines.** Grade lines should avoid high points where practical. Where high points occur, vacuum and relief valves may be necessary. Check the specified requirements.
2. **Pipe Support.** A properly installed water line does not move. Check blocking, movement at joints, bends, dead ends, and hydrants. Check wedging at all fittings.
3. **Water Line Sterilization.** Ensure that the sterilization of the water line is performed as specified. Consider the following:
 - a. **Main Flushing.** The water line main is to be thoroughly flushed with water until all entrained mud and debris have been removed.
 - b. **Sterilizing Agent.** Check that a sterilizing agent is added to the water line at the specified dosage. Ensure that the agent remains in the line for the minimum specified period.
 - c. **System Flush.** Ensure that the entire water line system is thoroughly flushed to remove the sterilizing agent.

622.2.1.3 Sanitary Sewer Lines

For sanitary sewer lines, see Section 603 and consider the following:

1. **Spigot End of Pipe.** Check that the spigot end of pipe is pointed downstream.
2. **Conflicts with Water Lines.** Check the distance separating water and sewer lines. Installation of sewer lines must be below the elevation of the water line, unless special construction techniques are employed at crossings.
3. **Grade/Manholes.** Check that a uniform grade is maintained between manholes.

Ensure that the top elevation of the manhole is readily accessible.
4. **Clean-Outs.** Check that a clean-out is placed every 100 feet at an angle pointing downstream.

622.2.1.4 Pipe Joints

Check the tightness of joints frequently during placement of pipe, and do not permit pipes to be joined in mud and water. Where flexible joints are used, check the acceptability materials, and consider the following:

1. **Flexible Gaskets.** Check the placement and positioning of flexible gaskets.
2. **Lubricant.** Check that a lubricant is properly applied at flexible joints.
3. **Hydrostatic Test.** Verify that a hydrostatic test is performed as soon as practical after placement.

622.2.1.5 Copper Pipe

Check the acceptability of the pipe and fittings supplied. Check for good workmanship (e.g., good bends, no burrs, clean pipe, pleasing location and placement).

622.2.2 Masonry and Tile

622.2.2.1 General Considerations

Consider the following guidelines during inspection of masonry and tile work:

1. Temperature. Verify that the ambient temperature is at or above the minimum temperature specified.
2. Leads. Verify that the Contractor erects leads at corners and jambs. Masons must use levels to check plumbness and to set string lines between leads.
3. Cutting. Check that the cutting of block and tile was done using a masonry saw. Blocks should be dry cut.
4. Wall Insulation. Verify the proper placement of wall insulation. Watch for broken and compressed insulation.
5. Horizontal Joint Reinforcement. Check that joint reinforcing is provided at designated locations (e.g., at courses designated on plans [usually 16 inches], under sills, over lintels, overlap reinforcement by six inches, and use prefabricated “T” and “L” sections at corners and intersecting walls).
6. Vertical Reinforcement (concrete block walls). Check size of rebar, lap and location of vertical reinforcement. Grout all cells with vertical reinforcement after masonry wall has attained sufficient strength to resist grout pressure. Vertical reinforcement should be tied to reinforcement extending from foundation as per plans. Vertical reinforcement is usually at sides of all openings, exterior corners, and 32 inches on center.
7. Bond Beams. Check that bond beams are provided at designated locations (e.g., under sill, above lintel level, top of wall, intermediate locations).
8. Door and Window Frames. Check that anchors are provided at each jamb. Verify that hollow doorframes are filled with mortar.
9. Embedded Items. Check that embedded items (e.g., sleeves, electrical conduit, heating ducts, recessed items) are installed properly as masonry is erected, not cut in afterwards. Check mechanical and electrical drawings for proper locations.
10. Caulking. Verify that frame openings are properly caulked.
11. Wall Bracing. Incomplete walls are not self-supporting. Check that they are properly braced to resist wind pressure.

622.2.2.2 Mortar Considerations

Verify that mortar is allowed to take its initial set before masonry joints are tooled. A good guideline is to use the “thumb-print” rule before tooling is performed. If masonry units move after the mortar takes initial set, require removal and resetting using fresh mortar. Consider the following additional guidelines:

1. Excess Mortar. Unless otherwise directed, verify that excess mortar is removed from the face and joints of brick and block before mortar takes its initial set. In insulated walls, verify that excess mortar is removed from the backside of masonry units. Check for excess mortar accumulation in the bottom wall cavity.
2. Proportioning. Mortar must be accurately proportioned and have all admixtures included. Check proportioning at least once a week and whenever mortar tenders are changed.
3. Re-temper. Mortar must not be re-tempered.
4. Mechanical Mixers. Mechanical mixers should be used on all but the smallest jobs.

622.2.2.3 Bricks and Concrete Block

Check bricks and concrete block for chips, cracks, and defects prior to installation and consider the following:

1. Placement. Undue shifting or realignment of brick or block is not permitted. During placement, consider the following:
 - a. Joints. Joints should be filled solidly as brick or block is placed.
 - b. Placement Method. “End buttering” (i.e., placing mortar on brick or block) or “pick and dip” (i.e., simultaneously picking up brick or block with one hand with mortar on trowel in the other) is acceptable. Throwing of mortar to fill joints after brick or block is laid (i.e., slushing) is unacceptable.
 - c. Mortar Bond. Check to ensure that mortar bond is not broken between newly laid brick or block joints. It is advisable to wait 24 hours to grout cells and to fill bond beams.
2. Structural Header Courses/Metal Ties. Verify that structural header courses and metal ties are installed between the face and back of masonry units. Check that metal ties are of the specified shape and size and placed at the proper spacing.
3. Joints. Check that all exposed joints are of uniform width.
4. Expansion Materials. Check the quality and location of expansion materials.

5. Brick Cleaning. Final clean-up of brickwork should be in accordance with the specifications. Check for loose bricks.
6. Anchors and Ties. Ensure that anchors and ties are installed as the work progresses.

622.2.2.4 Structural Glazed Tile

Check that joints in glazed tile are not be more than 0.25 inches in width. Verify that tile faces are cleaned with a clean, damp rag as the work progresses. Upon completion of walls, check that all tile surfaces are washed with soap powder and clean water. Stiff fiber brushes should be used, not metal brushes or acid solutions.

622.2.3 Building Infrastructure

622.2.3.1 Carpentry

Check acceptability of lumber grade and dimensions. Verify good artisanship and that the carpentry work meets governing building codes.

622.2.3.2 Roofing

Review safety requirements and consider the following:

1. Materials. Ensure that specified materials are being used.
2. Roof Surface. Verify that the roof is dry, smooth, firm, and free of dirt, projections, and foreign materials.
3. Flashing. Check flashing at all projections through roofing. Check for vented nailers at vertical leg of base flashing.
4. Drains and Vents. Verify that drains and vents are unplugged.
5. Roof Drains. Check roof drains for proper location and elevation. Also, check that roof drains are properly flashed, clean, and provided with grating.
6. Temporary Protection. Verify that wood runways are used for wheelbarrow traffic to protect roof sections.
7. Sheet Metal. Verify that construction and installation of sheet metal complies with the Contract and shop drawings. Check fabrication for good workmanship.
8. Corrugated Roofing. Check material before and after installation for defects and damage. Reject defective materials.

622.2.3.3 Doors and Windows

The installation of doors and windows must comply with the Contract and shop drawings. Consider the following:

1. Materials. Check materials for defects, warps, and buckles. Reject substandard materials.
2. Operation. Check doors and windows for proper operation.
3. Alignment. Check each door and window to see that it is plumb, square, and level.

622.2.3.4 Caulking, Glass, and Glazing

Consider the following during caulking, glass, and glazing work:

1. Grooves. Check that grooves are of sufficient depth and cleaned of mortar, dust, and foreign matter before caulking.
2. Caulking. Verify that caulking is uniform and relatively smooth without smearing.
3. Glass. Check the type and thickness of glass for acceptability. Verify that all glass surfaces are cleaned of labels, paint, putty, and other defacements.
4. Mirrors. Check mirror installation for compliance with the Contract and shop drawings. Verify that a concealed, non-tamperable mounting of mirrors is provided. Verify that mirrors are at designated height and properly centered with respect to fixtures. Ensure that mirrors are cleaned of labels, paint, putty, and defacements.

622.2.3.5 Ceramic Tile

Check size, color, and pattern of ceramic tile for acceptability and consider the following:

1. Tile Setting. Inspect tile setting for:
 - a. straight, level, perpendicular, and uniform 1/16-inch joints;
 - b. firmness of set; and
 - c. damaged or defective tiles.
2. Floor Tile. Check the laying of floor tile for:
 - a. cleanliness of subfloor, spread of adhesive, and initial set time;
 - b. cutting, trimming, setting, and fitting of tile; and
 - c. grouting and cleaning.

622.2.3.6 Toilet Partitions

Verify that toilet partitions are installed according to the manufacturer's instructions. Check for neat and accurate workmanship. Watch for unacceptable cutting and drilling of partition panels. Consider the following:

1. **Partition Placement.** Check the acceptability of partition fitting, jointing, and anchoring. Check that the assembly is straight, plumb, and level.
2. **Partition Damage.** Reject partition units that are dented, punctured, deeply scratched, or otherwise damaged. Slight mars, abrasions, and scratches may be touched up if they can be repaired to match undamaged parts.
3. **Hardware and Accessories.** Check the proper installation of all hardware and accessories.

622.2.3.7 Plumbing and Sprinkling Systems

See Section 603, Section 619, and Section 623 and consider the following:

1. **Material Damage.** Check pipes and fittings for damage. Reject damaged materials.
2. **Trench.** Inspect each length of pipe and fitting as it is lowered into the trench. Report all ground water conditions. Subsection 623.23 of the Standard
3. **Specifications requires a pressure and coverage test.** It is critical to pressure test the system before it is backfilled. In addition, the system should be run for a few days before the sod and plants are placed to troubleshoot the system and give the vegetation a good start.
4. **Pipe Caps/Plugs.** Verify that caps or plugs are placed on open ends of pipe where work is halted at the end of the day or where future connections are to be made.
5. **Material Submittals.** Check that required material certifications, samples, and approvals have been received prior to material installation.
6. **Sleeves.** Check the number and size of sleeves in floors and walls for acceptability before the floors are poured and during wall erection.

622.2.3.8 Soil, Waste, Drain, and Vent Piping

Check the following related to soil, waste, drain, and vent piping:

1. **Pipe and Fitting Material.** Check the acceptability of all pipes and fittings. Pay particular attention to the type, weight, and coating, if required.
2. **Pipe Slope and Alignment.** Check pipe slope and alignment for correctness.

3. Pipe Bedding and Cover Material. Verify that pipe bedding is at the proper grade and thoroughly compacted. Do not permit boulders to remain in bedding or cover material. Verify that pipe cover material is placed in uniform layers and thoroughly compacted.
4. Floor Drains. Check that floor drains are of the proper type and size and are equipped with sediment baskets or backwater valves. Verify that the floor pitches toward the drain.
5. Roof Drains. Check that roof drains are of the proper type and size. Verify that the roof drains are set at or slightly below the low points of the roof.
6. Sewer Pipe Bends. Do not allow perpendicular bends in the horizontal plane of sewer lines upstream from the septic tank.
7. Supports and Anchors. Check all supports and anchors for acceptability.
8. Pipes Under/Through Structures. Check the placement of pipes under and through footings and foundations to ensure that settlement will not affect pipes.
9. Vent Pipes. Check that all buildings and septic tanks have vent pipes.

622.2.3.9 Water Piping

Check water supply pipes from the outside service lines to the building for proper type, size, location, and elevation and interference with other underground utilities. Check clearance between water and sewer lines for acceptability and consider the following:

1. Frost Line. Check that pipes outside the building are below the frost line.
2. Non-Potable/Sewer Conflicts. Do not permit cross connections between potable and non-potable water supply or sewer drains.
3. Hangers. Check hangers for proper type, spacing, and secure anchorage.
4. Threaded Pipe. Do not allow the use of wicking in threaded pipe.
5. Pipes and Fittings. Check for proper type and weight of pipes and fittings. Check for the inappropriate use of galvanized and brass or copper pipe and fittings in the same run.
6. Fixtures. Check fixtures for complete trimming, fitting, and shut-off valves. Check fixtures for blemishes and the rigidity of fixtures.
7. Protection of Fixtures. Ensure that fixtures are properly protected during building construction. Prohibit the use of fixtures until the plumbing system is tested.
8. Accessory Equipment. Check that accessory equipment is of the proper type and installed in accordance with the Contract.
9. Controls/Regulators. Check for the proper installation of controls and regulators.

10. Flexible Connections/Vibration Eliminators. Check for the proper installation of flexible connections and vibration eliminators.
11. Testing. Prior to testing, check that all diaphragms and internal valve parts can withstand the test pressure without damage; otherwise, have them removed before the test is begun.
12. Final Cleanup. Check that all grease, paint spots, and debris are removed.
13. Final Adjustments. Check for the proper final adjustment of all fixtures, devices, and controls.
14. Operating/Maintenance Instructions. Check that the operating and maintenance instructions are posted where required.

622.2.4 Electrical System

622.2.4.1 General Considerations

The final inspection and permitting of electrical systems will require the services of a master electrician. Such assistance should be requested promptly from such authorized individuals. Consider the following:

1. National Electrical Code. The electrical installation must conform to the latest edition of the National Electrical Code and applicable State and local ordinances.
2. Materials and Equipment. Check materials and equipment for compliance with the Contract and approved shop drawings when they are delivered to the job. Examine equipment for damage due to shipping.
3. Permits. Verify that all required permits have been properly posted.
4. Grounding. All grounding must be in accordance with the latest edition of the National Electrical Code and approved by a State electrical inspector.
5. Conduit and Wire Size. Know if the conduit system is to be installed concealed or exposed. Check that the size of conduit and wire meet the minimum specified requirements.
6. Buried Conduit. Where designated, ensure that buried electrical conduit is placed and approved before the floor slab is poured. Where required, verify that the exterior of buried conduit is painted with a bituminous-based paint.
7. Conduit Damage. Inspect for damage and deformation of conduit during installation.
8. Conduit Bends. Check the number of bends in conduit to verify that it does not exceed the maximum in a single run.

9. Conduit Alignment. Verify that exposed conduit runs are installed parallel or perpendicular, as appropriate, to walls and structural members. Check that vertical conduit runs are plumb. Exceptions may be necessary due to obstructions or space limitations.
10. Pulling Wire. Observe pulling of wires and cables and watch for damage to sheaths, jackets, and insulation.
11. Panelboard Directories. Verify that panelboard directories are complete and correctly identify the circuits and equipment served.

622.2.4.2 Lamps and Lighting Fixtures

For the inspection of lamps and lighting fixtures, consider the following:

1. Material Damage. Check fixtures for chipped porcelain, cracked glass and plastic, bent louvers, and the overall finish.
2. Lamp Wattage. Check that the lamp wattage is of the correct rating.
3. Lamp Type. Check ballasts for fluorescent and mercury vapor lamps to ensure suitability for circuit voltage and high-power factor type. Determine if the slow, rapid, or instant start feature is specified and installed.
4. Fixture Alignment. Installation should be plumb and have good horizontal and vertical alignment.

SECTION 623 IRRIGATION SYSTEM

623.1 GENERAL

The work for irrigation systems generally consists of constructing a pressurized irrigation mainline and lateral transport lines that provide coverage to the limits shown in the Contract. The Contractor will establish the exact locations to fit field conditions and receive approval from the Project Engineer prior to construction. The construction of irrigation systems must conform to all applicable State and local codes.

623.2 INSPECTION GUIDELINES

623.2.1 Before Construction

Ensure that all equipment and materials to be installed are new. Verify that equipment to be installed conforms to the list of equipment submitted and approved.

623.2.2 During Construction

During the construction of irrigation systems, consider the following:

1. Staking. Verify that staked locations are approved. The Contractor must protect stakes during construction.
2. Trenches. Check trench bottoms for a flat grade that will support the pipe evenly. Verify that the depth will provide for the specified minimum cover. For mainline pipe, ensure that the bottom of the trench is flat, and excavation and backfill conform to Sections 206 and 703 of the Standard Specifications.
3. Pipe. Check pipe for correct size and proper identification markings. For mainline pipe, check that type of pipefitting conforms to the specified type in relation to the size of pipe (i.e., solvent weld or rubber gasket). Check that pipe ends are taped during installation to protect against entry of foreign material.
4. Sleeve Pipes. When installing sleeves, check that the location of the sleeve is recorded in the As-Constructed Plans and marked with magnetic tape for future location.
5. Mainline Low Points. Ensure that drain valves are placed at low points along the mainline.
6. Clearance. Check for specified clearances between line crossings.
7. Kick Blocks. Ensure that kick blocks are installed as required.
8. Wiring. Check wire for correct color code. Check that wire is located properly in the trench. Where more than one wire is placed in a trench, check that the wires are correctly taped together. Check that wire is placed at least at the minimum depth.

9. Underground Marking Tape. Ensure that underground marking tape is placed with mainline pipe that does not have control wire in the same trench.
10. Valve Boxes. Check valve boxes for proper markings on the cover and for installation to the correct grade.
11. Pressure Test. Verify that a pressurized or volumetric test for mainline leakage is performed prior to backfilling joints and fittings.

623.2.3 After Construction

After the construction of an irrigation system, consider the following:

1. Coverage Test. The Contractor is required to perform the coverage test in the presence of the Project Engineer. Verify that adjustments are performed.
2. As-Constructed Plans. The Contractor will provide detailed As-Constructed Plans of the irrigation system.

SECTION 624 DRAINAGE PIPE

624.1 GENERAL

This specification allows the Contractor to choose any pipe material allowed in Table 624-1 for the pipe class specified in the contract. The Contractor shall state at the Pre-Construction Conference which pipe material was chosen. Construction requirements are the same as for section 510 or 603 as applicable. Refer to those sections for further guidance.

SECTION 625 CONSTRUCTION SURVEYING

625.1 GENERAL

Construction surveying shall be performed in accordance with Section 625 of the Standard Specifications and the CDOT Survey Manual.

625.2 - 625.10 RESERVED

625.11 3D ENGINEERED CONSTRUCTION SURVEYING (3DECS)

Your project may be one that the Resident Engineer or Project Manager determined meets the criteria for providing three-dimensional modeling data to the contractor to be used for bidding and construction. To determine if yours is such a project, check the Project Special Provision, Revision of Section 102 - Project Plans and Other Data and see if it includes the statement that such documents are available.

The Contractor may use the data from these files to create efficiencies during construction. The primary benefits are less staking and improved efficiency of earthwork operations. The data can be input directly into heavy machinery enabling the machinery to make automatic adjustments, or the data can be provided to the operator enabling the operator to make the machine adjustments.

Chapter 6 of the Survey Manual has been modified for projects in which the Contractor chooses to use 3D Engineered Construction Surveying (3DECS). There should be discussions at the Pre-survey Conference regarding use of 3DECS.

The CDOT Standard Specification Section 625 and the Survey Tabulation Sheet have been modified such that should the Contractor choose to use 3DECS, less staking is required. Less staking will make it more difficult for CDOT to check the work, but minimal staking is still required. Should you feel you need more surveying to check the work, you can require more staking per Standard Special Provision, Revision of Section 105 - Construction Surveying where we pay the contractor an hourly rate for additional surveying.

SECTION 626 MOBILIZATION

626.1 GENERAL

Mobilization is governed by Section 626 of the Standard Specifications. Item 626 - Mobilization is automatically calculated by the Department's construction management software.

SECTION 627 PAVEMENT MARKING

627.1 GENERAL

Pavement marking material and construction requirements are detailed in Section 627 of the Standard Specifications, and placement must be in conformance with the manufacturer's recommendations, the Manual of Uniform Traffic Control Devices, and the CDOT M&S Standard Plans.

627.1.1 Surface Preparation and Payment Considerations

Preparation of the pavement surface prior to applying extruded thermoplastic, epoxy, and preformed tape is required and should be performed in accordance to the manufacturer's recommendations. This cleaning shall remove oil, dirt, dust, grease, and similar foreign materials, and payment is generally included under the pavement-marking item. Because of the much greater effort required to remove existing markings from both asphalt and Portland cement concrete pavements, their removal is generally specified as a separate item of work and paid for independent of the pavement-marking item.

627.2 INSPECTION GUIDELINES

627.2.1 Before Construction

Before applying pavement markings, consider the following:

1. **Pavement Marking Plan.** If the Contract does not include a pavement-marking layout, verify that the Contractor has provided a layout of existing conditions for approval and modification.
2. **Control Points.** Check control points for correct size and placement to ensure compliance with the pavement marking plan.
3. **Conflicts.** Verify that there are no conflicts between typical section, pavement marking plan, or existing markings.
4. **Material.** Confirm the type of material (e.g., paint, thermoplastic, epoxy, and tape) to be installed. Ensure that the material to be installed meets specifications.
5. **Surface Preparation.** Ensure the surface is properly cleaned and free of moisture, grease, oil, dirt, and laitance. Check the need for primer, sandblasting, water blasting, grinding, or grooving.
6. **Temperature.** Check that air temperature complies with the specifications and manufacturer's recommendations.
7. **Signing Conflicts.** Check for conflicts with highway signing.

627.2.2 During Construction

During the placement of pavement markings, perform regular checks to ensure that the surface is clean and dry. Regularly check completed lines for good workmanship and straightness. Consider the following additional guidelines:

1. Application Procedures. Check application procedures for compliance with the manufacturer's recommendations.
2. Application Rate. Check application rate of paint, thermoplastics, and epoxies for compliance. The Contractor may use a meter or dip their tanks for measurements before and after striping. Verify the application rate is correct by measuring the area striped and calculating the minimum and maximum rate allowed in the spec.
3. Beads. Check that the application rate of beads complies with specified requirements.
4. Protection. Make sure that adequate cones are used to prevent tracking by vehicular traffic.
5. Full-Compliance Markings. Verify the proper application of full-compliance markings at crossovers, detours, and no-passing zones.
6. Conflicting Pavement Markings. Check that conflicting or confusing pavement markings are properly removed. Removal should be done by water blasting to help prevent "ghosting" of the removed pavement markings.
7. Modified Epoxy Pavement Marking. Verify that Certificates of Compliance have been received and consider the following:
 - a. Curing. Check for proper curing of epoxy marking material.
 - b. Component Ratio. Ensure that proper equipment is on hand that is capable of metering components at the correct ratio and able to maintain the material at the correct temperature.
 - c. Thickness. Check that the correct thickness of material is applied.
8. Thermoplastic Pavement Marking. Ensure that suitable equipment is on hand to provide proper extrusion, heating, mixing, and control of the flow of material. Consider the following:
 - a. Alignment and Size. Ensure that a continuous uniformity in stripe dimensions and alignment is maintained.
 - b. Thickness. Check that the correct thickness of material is applied.
9. Preformed Pavement Marking. For the application of preformed pavement markings, consider the following:

- a. Existing Pavement. When placed on existing cold pavement, check for a clean, dry, and properly prepared surface. Verify if sandblasting is required. Ensure that primer has been properly applied. Check for appropriate splicing sequence and roller weight.
 - b. Inlay. For hot bituminous inlay placement, ensure that the material is applied in the proper location and sequence on the new mat. Check that the pavement surface is at the recommended temperature to obtain complete inlay.
10. Pavement Marking Tape. Where pavement-marking tape is used, ensure that the tape is in conformance with the Contract and is suitable for temporary use. Consider the following:
- a. Tape Application. Ensure that the tape is clean and pressed down until it completely adheres to the surface. Check for correct lengths and intervals, and that locations are according to plan or as directed.
 - b. Tape Removal. Ensure that temporary tape is removed prior to subsequent lifts of hot bituminous pavement.

SECTION 628 RESERVED

SECTION 629 SURVEY MONUMENTATION

629.1 GENERAL

Survey monumentation shall be performed in accordance with Section 629 of the Standard Specifications and the CDOT Survey Manual.

SECTION 630 CONSTRUCTION ZONE TRAFFIC CONTROL

630.1 GENERAL

Coordination and advance planning by the Contractor, Traffic Control Supervisor, and the Project Engineer are required to provide for the safe and efficient maintenance and protection of traffic during construction. Every reasonable and practical effort should be made to reduce hazards and inconvenience to the traveling public and to adequately protect project personnel at the site. The Traffic Control Plan and Method of Handling Traffic must address the items shown in subsection 630.10 of the Standard Specifications.

CDOT and Contractor personnel must continually monitor the construction area and immediately report potentially hazardous situations for correction. The topic of construction zone traffic control will have been thoroughly addressed at the Preconstruction Conference.

630.2 TRAFFIC CONTROL REVIEW PROGRAM

630.2.1 Overview

The Traffic Control Review Program has been established to provide assistance in administering the traffic control aspects of a construction project. The Traffic Control Review Program relies on the experience and expertise of the Resident Engineer to assist Project Engineers. The Traffic Control Review Form is used to document the results of the Traffic Control Review.

630.2.2 Implementation Procedures

The objective of the Traffic Control Review Program is to obtain an "in compliance" or "yes" response to each question posed on the Traffic Control Review Form. The following procedures are used to implement the Traffic Control Review Program:

1. Traffic Control Review Frequency. The Project Engineer and the Resident Engineer will perform a joint Traffic Control Review once each calendar year for each active construction project.
2. Substitution of Reviewer. The Region Program Engineer may appoint a qualified substitute to the Resident Engineer to participate in the Traffic Control Review; however, the substitute will not be assigned to the project being reviewed.
3. Traffic Control Review Form. The Traffic Control Review Form will be used to document the results of the Traffic Control Review. A copy of each completed form will be maintained in the project files. Contact the Project Development Branch for blank copies or an electronic version of the Traffic Control Review Form. See Appendix B for an example of a properly completed Traffic Review Form.

4. Deficiency Corrections. All deficiencies noted during the Traffic Control Review will be immediately reported to the Contractor for correction. The maximum time period for correction is 24 hours.

630.2.3 Inspections During Non-Working Hours

The Traffic Control Review Program requires night inspections of traffic control. The following guidelines have been established to ensure statewide uniformity:

1. Traffic Control Supervisor Inspections. The Project Engineer is responsible for ensuring that the Traffic Control Supervisor inspects for compliance the work zone traffic control during non-working hours, including nights and weekends.
2. CDOT Inspections. The Project Engineer, or a qualified CDOT employee, should make at least one nighttime inspection upon implementation of a new Method of Handling Traffic that includes nighttime traffic control devices.

630.2.4 Review of Method of Handling Traffic

The Project Engineer is responsible for reviewing the Contractor's Method of Handling Traffic. Check that the Method of Handling Traffic complies with the requirements of the Manual of Uniform Traffic Control Devices, CDOT M&S Standard Plans, and the project's Traffic Control Plan. Verify that the Method of Handling Traffic provides adequate protection for workers, motorists, pedestrians, and bicyclists. Consider the following:

1. Contractor Review. Verify that the Method of Handling Traffic has been reviewed and initialed by the Contractor.
2. Speed Reduction. If a speed reduction is requested, check that the Method of Handling Traffic complies with the conditions of the approved CDOT Form 568 - Authorization and Declaration of Temporary Speed Limits.
3. Emergency Vehicle Access. Ensure that there is an adequate plan for emergency vehicle access.
4. Unnecessary Devices/Flaggers. Do not approve a Method of Handling Traffic that includes unnecessary devices or flaggers. Part 6 of the Manual of Uniform Traffic Control Devices specifies the type, number, location, and arrangement of devices and flaggers that are acceptable for use in construction applications. Occasionally, Contractors will propose more devices and flaggers than are warranted, making a false assumption that such practice will provide additional safety. On the contrary, such practice can be a detriment to safety for an increase in cost. Too many devices and flaggers can cause confusion, render other control measures ineffective, and exacerbate the hazard potential. If a Contractor insists on using unnecessary traffic control, contact the Region Traffic Engineer or the Safety and Traffic Engineering Branch for immediate assistance.

5. Pedestrian and Bicycle Traffic. Verify that the Method of Handling Traffic adequately provides for pedestrian, bicycle, and other non-vehicular traffic. Check that bicycle and recreational trail detours have been correctly identified and signed.
6. Access/Crossovers. Verify that the Method of Handling Traffic adequately provides access for construction and maintenance traffic, including turnaround locations. Ensure that median crossings and crossovers comply with the requirements of the Contract.
7. Restrictive Clearances. Where the Method of Handling Traffic includes detours and construction activities at bridge structures, the Project Engineer will verify that the appropriate signing has been provided and check for restrictive vertical and lateral clearances (see Appendix D). Consider the following:
 - a. Vertical Clearance. If a vertical clearance of less than 16 feet six inches is necessary, verify that the condition is appropriately signed and notify Craig Smith (craig.smith@state.co.us) and Dan Wells (dan.wells@state.co.us) in the Maintenance and Operations Branch immediately by electronic mail. The subject line of the message should read "RESTRICTION ALERT." Include the following information in the body of the message:
 - i. highway number,
 - ii. beginning mile post for the restriction,
 - iii. ending mile post for the restriction,
 - iv. direction of travel that is restricted,
 - v. restriction description (e.g., vertical, lateral),
 - vi. beginning date and approximate time of restriction, and
 - vii. name and phone number of contact for the project restriction.

Note that the ending date of the restriction is an approximation. Although, the restriction will not be removed from the report until notification of the end of the project, an estimate assists the permit writers in answering queries about the restriction.

- b. Lateral Clearance. If a restriction to the existing lane width or shoulder is necessary, immediately notify the Maintenance and Operations Branch by electronic mail as previously discussed for vertical clearance restrictions.
- c. Advance Notice. Provide the Maintenance and Operations Branch with as much advance notice as possible to allow them to properly notify permit holders. As soon as the Contractor provides any indication that height or width restrictions will be necessary, immediately use the notification procedures contained in Construction Manual subsection 630.2.4, number 7, paragraphs a. and b.

Additionally, notify the Maintenance and Operations Branch when the restriction may be lifted.

Vertical and horizontal clearance restrictions and the notification process must also be discussed at the Preconstruction Conference.

For Local Agency projects, the Local Agency Project Manager must make the required notification to the CDOT Maintenance and Operations Branch as described above, and must also send a copy of the notification to the CDOT Resident Engineer.

630.2.5 Responsibilities of the Traffic Control Supervisor

The Traffic Control Supervisor is an individual other than the Contractor Superintendent and must have a current Flagger's Certificate and certification from the American Traffic Safety Services Association or the Colorado Contractors Association. The following is presented to assist the interpretation of subsection 630.10 of Standard Special Provision, Revision of 630 - Construction Zone Traffic Control and to ensure statewide uniformity in administration. The Traffic Control Supervisor is responsible for the following:

1. Method of Handling Traffic. The Traffic Control Supervisor will prepare, revise as needed, and implement each Method of Handling Traffic in accordance with the Traffic Control Plan. Each Method of Handling Traffic must designate the traffic control operations and devices necessary for its respective phase of construction. The Method of Handling Traffic must be submitted on 8.5-inch by 14-inch or 11-inch by 17-inch paper for convenient use by project personnel. The Traffic Control Supervisor will provide multiple copies of the Method of Handling Traffic for distribution to the Contractor and all subcontractors that are involved in the construction phase. Alternatively, the Contractor may submit MHT's electronically for review and electronic signature by the Project Engineer. Electronic copies may be retained for records. See Section 630.2.4 for guidance on reviewing Methods of Handling Traffic.
2. Communications. The Traffic Control Supervisor will provide Traffic Control Management on a 24-hour-per-day basis. The required minimum level of communications includes:
 - a. Contractor. The Traffic Control Supervisor will communicate with the Contractor to determine what traffic control measures need to be provided by subcontractors and material suppliers.
 - b. Local Agencies. The Traffic Control Supervisor will inform local police and fire agencies of any lane closures or delays. Regular updates are required as operations change.
 - c. Emergency Contact Numbers. The Traffic Control Supervisor will provide emergency contact numbers of Contractor and CDOT personnel to local police and fire agencies. This allows the proper project personnel to be notified in case of an emergency on the project during working or non-working hours.

- d. Response Time. During non-working hours, the Traffic Control Supervisor, or designee, will respond to the site within 45 minutes of notification; however, if not certified, a certified respondent must arrive at the site within two hours of initial notification.
3. Inspections. The Traffic Control Supervisor, or certified designee, will inspect traffic control devices on each calendar day that they are in use, masked, or turned away from traffic. These inspections will include at least one night inspection per week. Verify that the proper type and number of traffic control devices are located and arranged as designated on the active Method of Handling Traffic. Check devices for damage, undesirable relocation, and acceptable visibility. Ensure that lights and flashing beacons are functioning properly. Supervise the cleaning of devices as frequently as necessary to preserve legibility and retroreflectivity. All devices must be cleaned a minimum of once every two weeks.
4. Traffic Control Inspection Diary. The Traffic Control Inspection Diary must be signed by the person that conducted the inspection (i.e., Traffic Control Supervisor or certified designee). The Traffic Control Inspection Diary must contain a statement certifying that all traffic control devices are clean and properly maintained and include the following information:
 - a. date and time of inspection;
 - b. project number;
 - c. list of flaggers and hours;
 - d. uniformed traffic control hours used;
 - e. Method of Handling Traffic used;
 - f. weather conditions;
 - g. interference with normal traffic flow,
 - h. detours in use;
 - i. work performed by Contractor, subcontractors, or utility companies;
 - j. location of flagging stations and flagging hours,
 - k. problems encountered and corrections made;
 - l. crashes or other incidents involving the traveling public;
 - m. types and quantities of traffic control devices used;
 - n. maintenance or cleaning performed on the traffic control devices; and

- o. any unusual conditions, significant delays or problems encountered during the day.
5. Project Meetings. The Traffic Control Supervisor will attend all project scheduling meetings. This will help ensure that the Traffic Control Supervisor is properly informed of the planned operations so that an appropriate Method of Handling Traffic can be developed. Any conflicts in traffic control between subcontractors should be addressed at project scheduling meetings.
6. Relief Flagging. The Traffic Control Supervisor will not act as a flagger, except in emergency situations or when it is necessary to relieve the stationed flagger for a period of a half hour or less (e.g., lunch breaks, rest periods). Relief flagging will be performed only when such action will not interfere with the normal duties of the Traffic Control Supervisor; otherwise, another certified flagger must be provided.

630.2.6 Flagger Certification

All flaggers on CDOT projects must possess a Flagger's Certification Card in accordance with subsection 630.14 of the Standard Specifications. Subsection 630.14 requires that all flaggers on CDOT projects be properly certified, having successfully passed the Department's minimum training requirements within two years of starting work on the project. The Department's minimum training requirements are defined in CDOT Procedural Directive 306.1 - Flagger Training and Certification Program. Note that CDOT does not certify non-CDOT employees for flagging duties. The certification requirements include reviewing the latest edition of the CDOT Flagger's Training Manual, viewing a flagger training video, and obtaining a passing score of at least 80 percent on a Flagger Proficiency Test, which must be administered by a Registered Flagger Proctoring Agency. Contact the Project Development Branch for a list of Registered Flagger Proctoring Agencies. Public or private entities desiring to become a Registered Flagger Proctoring Agency may contact the Department as follows:

Colorado Department of Transportation
Safety and Traffic Engineering Branch
Work Zone Safety Program
Attn: Work Zone Safety Coordinator 2829 W. Howard Place.
Denver, CO 80204 (888) 639-3271
dot_cdot_flagger@state.co.us

630.3 INSPECTION GUIDELINES

Use the Traffic Control Review Form to inspect the construction zone traffic control provided by the Contractor, and consider the guidelines presented in the following Sections.

630.3.1 Traffic Operations and Project Documents

Verify that the following documents are available at the project site:

1. Manual of Uniform Traffic Control Devices. Check that a current version of the Manual of Uniform Traffic Control Devices with up-to-date Federal Highway Administration revisions and current CDOT supplement is readily available.
2. Plans. Verify the availability of the Traffic Control Plan sheets, CDOT M&S Standard Plans, and detour plan and profile sheets, where applicable.
3. Method of Handling Traffic. Inspect traffic control operations for compliance with the approved Method of Handling Traffic. Verify that each Method of Handling Traffic addresses the following (see Section 630.2.5):
 - a. approved by Contractor and CDOT for each construction operation,
 - b. tabulation of traffic control devices and flaggers,
 - c. match CDOT Form 568 for location and approved speed limitations,
 - d. provide for emergencies, special events, and non-vehicular traffic,
 - e. provide for access, median crossings, and turnaround locations.
4. Flagger Certifications. Ensure that current and proper certifications from the American Traffic Safety Services Association or the Colorado Contractors Association are provided for the Traffic Control Supervisor and all flaggers. See Section 630.2.6 for additional information on flaggers.
5. Emergency Contacts. Verify that 24-hour Contractor emergency phone numbers are provided for the Traffic Control Supervisor and response personnel. Ensure that the appropriate Contractor and CDOT numbers are given to the Local Agency. As needed, contact the Local Law Enforcement Agency and request copies of any crash reports involving work zone traffic control. Review the crash reports and determine if improvements are warranted.
6. Speed Reductions. Verify that a CDOT Form 568 - Authorization and Declaration of Temporary Speed Limits has been approved for requested speed reductions, and ensure a copy of the approved form is retained in the project files.
7. Traffic Control Review. Verify that a Traffic Control Review is performed at least once per calendar year.

630.3.2 Traffic Control Supervisor

Verify that the Traffic Control Supervisor is available on the project as required, is appropriately dressed (e.g., reflectorized clothing at night), and making and documenting periodic project inspections, day and night, as required (see Section 630.2.5). Consider the following:

1. Project Documents. Check that the Traffic Control Supervisor has a copy of the documents presented in Section 630.3.1.
2. Certifications. Know if an American Traffic Safety Services Association or a Colorado Contractors Association certification will require renewal during the course of the project. Ensure that the Traffic Control Supervisor has a current flagger certification if used as a relief flagger (see 630.2.6).
3. Inspections. Ensure that night inspections are being conducted and properly documented. Check that device cleaning and maintenance activities are being properly documented.
4. Daily Diary. Verify that the Traffic Control Supervisor is submitting a daily diary. Check that the diary properly reports problems and unsafe conditions, crashes, flagging and device quantities for the active Method of Handling Traffic, including any changes. Verify that discrepancies, as noted in the diary, have been corrected in a timely manner.

630.3.3 Flaggers

During construction, check the following with respect to flaggers:

1. Certifications. Verify that current and proper flagger certifications are provided. Check that the card matches the person. Know if the certifications will require renewal during the course of the project. See Section 630.2.6 for additional information.
2. Dress/Equipment. Check the flaggers' dress and equipment to ensure compliance with the Standard Specifications and the Manual of Uniform Traffic Control Devices. Pay particular attention to compliance of the following:
 - a. Fluorescent orange-red or fluorescent yellow-green hardhat and vest of the proper type of material,
 - b. correct size and shape of "Stop/Slow" paddle, and
 - c. proper reflectorized clothing and equipment for night operations.

CDOT currently requires all of our CDOT-employed highway construction and maintenance workers, including CDOT flaggers, to wear high-visibility vests and hardhats with background material color either fluorescent orange-red or fluorescent yellow-green as defined in the latest version of the ANSI/ISEA standard (see CDOT Procedural Directive 80.1).

3. Methods. Check that proper flagging methods are being used.
4. Location. Check flagger location as follows:
 - a. flagger facing oncoming traffic,

- b. visible to oncoming traffic,
- c. proper distance in advance of the work, and
- d. flagger station illuminated during night operations.

630.3.4 Construction Signing

The American Traffic Safety Services Association publication Quality Standards for Work Zone Traffic Control Devices may be used as a guideline when inspecting signing and traffic control devices. Inspect construction signing for proper installation and satisfactory condition. Consider the following:

1. Contract Plans and Specifications. Ensure that signs conform to the Contract, including the CDOT M&S Standards and the Manual of Uniform Traffic Control Devices. Pay particularly attention to compliance of the following:
 - a. size, shape, and color;
 - b. retroreflective sheeting; and
 - c. appropriate location.
2. Traffic Control Plan/Method of Handling Traffic. Verify that signs and devices conform to the Traffic Control Plan and the active Method of Handling Traffic.
3. Sign Condition. Check that the signs are clean, legible, and in good repair.
4. Breakaway Bases. Check for required breakaway bases on post mounted signs. Posts that do not meet these conditions should be rejected and replaced. Please see CDOT Standard Plan S-614-5, sheet 1 of 2, for clarity.
5. Temporary Signs. Check that temporary signs are properly weighted, mounted, and at the correct height.
6. Stored Signs. Signs not in use should be properly stored. Check that signs are:
 - a. lying flat, including the base;
 - b. beyond the shoulder;
 - c. outside the normal roadside recovery area; and
 - d. not on landscaped areas or sidewalks.
7. Conflicting Signs. Ensure that conflicting permanent signs are properly masked.
8. Retroreflective Sheeting. Confirm that that sign and barricade sheeting placed on the project complies with the CDOT Construction Zones Retroreflective Sheeting Materials

Guide. The Safety and Traffic Engineering Branch, in conjunction with the FHWA, has developed this publication to facilitate inspection of the proper application of retroreflective sheeting materials on CDOT projects. The publication contains samples of retroreflective sheeting that are approved by CDOT and FHWA and will be updated as needed. Contact the Safety and Traffic Engineering Branch at (303) 757-9654 for additional information.

630.3.5 Traffic Control Devices

Traffic control devices are used to warn the traveling public of hazards, advise them of the proper path through the work zone, delineate areas where they may not operate, and separate them from construction workers. The effectiveness of these markings depends on their visibility upon installation and throughout the life of the project. Because it is not practical to require new devices to be installed on each construction project, the American Traffic Safety Services Association has published the document *Quality Standards for Work Zone Traffic Control Devices* as guidance to use in assessing the quality of traffic control devices used in construction zones. Copies of this publication can be obtained by contacting the Safety and Traffic Engineering Branch at (303) 757-9654.

Work zone devices designated by FHWA as Category I, II, or III, shall meet NCHRP 350 requirements. Devices designated as Category IV, including but not limited to portable or trailer-mounted devices such as flashing arrow panels, temporary traffic signals, area lighting supports, and changeable message signs, are not required to meet NCHRP 350 requirements.

Except for Category IV devices, the Contractor shall obtain and present to the Engineer the manufacturer's written NCHRP 350 certification for each work zone device before it is first used on the project.

Consider the following during the inspection of traffic control devices:

1. Flashing Arrow Panels. Ensure that flashing arrow panels are in the correct location and functioning properly. Check flashing arrow panels for:
 - a. properly working lights in the correct mode,
 - b. correct automatic dimming at night, and
 - c. correct panel size mounted at the correct height.
2. Channelizing Devices. Ensure that channelizing devices conform to the requirements of the Contract Specifications, *Manual of Uniform Traffic Control Devices*, *Method of Handling Traffic*, and the project's Traffic Control Plan. Pay particular attention to the following:
 - a. correct dimensions in a clean, serviceable condition,
 - b. proper retroreflectorized sheeting or collars,

- c. correct placement with proper taper lengths and spacing,
 - d. proper and functioning warning lights that are set in the correct mode, and
 - e. weighting by acceptable methods.
3. Concrete Barriers. Check that temporary concrete barriers are correctly placed with proper treatment at end sections. Pay particular attention to the acceptability of connecting pins and the color and retroreflectorization of sheeting.
4. Impact Attenuators. Ensure that impact attenuators are properly located and installed according to the Contract and manufacturer's recommendations including:
 - a. correct weight of proper material placed in each barrel, and
 - b. provisions for preventing filler material from freezing.
5. Quality Standards. Temporary traffic control devices are subjected to wear during use, storage, shipment, installation, relocation, and removal. A large number of worn devices on a project are unacceptable. The American Traffic Safety Services Association publication Quality Standards for Work Zone Traffic Control Devices should be used to assess device quality. Such assessments should be made while the devices are in storage before use on the project, during initial set up, and periodically during the life of the project. Require removal and replacement of unacceptable devices in accordance with subsections 630.02 and 105.01 of the Standard Specifications.
6. Flashing Beacons. The S-Standard, S-630-3, requires that flashing beacons utilize a typical 12" signal head lens with a 150 Watt lamp or approved ITE Amber LED. Do not accept an 8" lens with 110-Watt lamps. Although the 8" lens meets the requirements of the MUTCD, it does not meet the requirements of the M&S Standards and is unacceptable for use on CDOT projects.

630.3.6 Temporary Pavement Markings

Ensure that temporary pavement markings meet the requirements of the Method of Handling Traffic, striping plan, and Contract Specifications. Check temporary markings for correct placement in a timely manner, and ensure that conflicting markings have been completely removed.

630.3.7 Pilot Car Operations

Ensure that flaggers and pilot vehicles are properly equipped and located in accordance with the requirements of the Manual of Uniform Traffic Control Devices.

CDOT CONSTRUCTION MANUAL

MISCELLANEOUS CONSTRUCTION CONFERENCE AGENDAS

Appendix A

APPENDIX A. MISCELLANEOUS CONSTRUCTION CONFERENCE AGENDAS.....	A-1
CONFERENCE AGENDAS	A-3
PRECONSTRUCTION CONFERENCE NOTIFICATION AND AGENDA.....	A-4
PRECONSTRUCTION CONFERENCE AGENDA	A-8
HOT MIX ASPHALT PRE-PAVING CONFERENCE AGENDA.....	A-9
PRE-DEMOLITION CONFERENCE AGENDA	A-33
PRE-ERECTION CONFERENCE AGENDA	A-44
STRUCTURAL CONCRETE PRE-POUR CONFERENCE AGENDA	A-55
CONCRETE PAVEMENT PRE-PAVING AND QC/QA CONFERENCE AGENDA	A-68
ENVIRONMENTAL PRECONSTRUCTON CONFERENCE AGENDA AND ATTENDANCE ROSTER	A-70

CONFERENCE AGENDAS

Appendix A contains several example Conference Agendas to assist in facilitating meetings for various conferences required by the Department, including:

Where extensive utility adjustments or relocations are involved, it is desirable to hold an additional Preconstruction Conference to resolve and coordinate utility issues. All affected utility companies should attend this meeting, and the Contractor should furnish a detailed construction schedule of proposed utility activities to facilitate coordination. Where the project requires extensive survey work, use the appropriate Pre-survey Conference Agenda Form(s) (i.e. Aerial Survey Form, Construction Survey Form or Preliminary Survey Form) presented in the CDOT Survey Manual.

Each of these examples presents a minimum set of topics that should be discussed during the conference; however, not all topics will be covered for every project in every Region. Prior to its use, thoroughly read the content of the agenda and consider the special needs of the particular project and specific Region. Contact the Area Engineer in the Contracts & Market Analysis Branch for additional information. Copies of these agendas are available from the CDOT website.

PRECONSTRUCTION CONFERENCE NOTIFICATION AND AGENDA

The following examples include a notification letter for the Preconstruction Conference and a Preconstruction Conference Agenda to assist in facilitating the meeting. The agenda presents a minimum set of topics that should be discussed during the Conference; however, not all topics will be covered for every project in every Region. Modify this agenda to meet the needs of your project. Copies of this Agenda are available from the CDOT website:

https://www.codot.gov/business/designsupport/bulletins_manuals/construction-manual

Contact the Area Engineer in the Contracts & Market Analysis Branch for additional information.



Project Development Branch
2829 W. Howard Place
Denver, Colorado 80204

Date RE:

Name Of recipient
Company
Another Line
555 Address St. Apt. 55
Denver, CO 80222

To Whom It May Concern:

This is to confirm that the PreConstruction Conference for the XXXX project has been scheduled for [DATE]. The conference will be held at [TIME] in/at [LOCATION NAME WITH ADDRESS AND GENERAL DIRECTIONS IF NECESSARY].

If your superintendent is unable to attend, the meeting will be rescheduled. You may invite representatives of each subcontractor.

In addition, you need to provide the information previously requested, at least two working days prior to the conference. You may hand carry or mail the information to the Resident Engineer's office at [ADDRESS]. Should you choose to mail it, please allow an additional three to four working days for delivery. Timely submittal of the information will assure that the conference will continue as scheduled.

You must obtain consent to sublet portions of the work prior to that portion of the work beginning. Form 205 - Sublet Permit Application is required for each subcontractor on the project. Please allow [NUMBER] days for CDOT to process the forms. If you need copies of this form, please contact the Resident Engineer or Project Engineer listed below:

[RESIDENT ENGINEER
PROJECT ENGINEER]

The general outline for the conference agenda will be as follows:

Project Organization	Right of Way
Utilities/Railroad	Materials
EEO and Labor Compliance	Safety
Project Status	Surveying
General Comments	

Utility/Railroad/Entity companies with facilities affected by work on this project are:

<u>COMPANY</u>	<u>CONTACT</u>	<u>PHONE</u>
Utility Name	Person	XXX-XXX-XXXX

Please call the Project Engineer at (XXX) XXX-XXXX with any questions.

Sincerely,

Resident Engineer Signature Block

CC: Federal Highway Administration
Project Development Branch
Bridge Design and Management Branch
Office of Public Relations
Region Maintenance Section
Region Traffic and Safety Section
Region Program Engineering Section, Right of Way Unit
Region Program Engineering Section, Materials Laboratory Unit
Region Program Engineering Section, Survey Unit
Region Program Engineering Section, Utilities Unit
Region Planning and Environmental Section
Region Landscaping Unit
Region Equal Employment Opportunity Office
Project Engineer
Head Tester
Resident Engineer
Project File

Project Development Branch
2829 W. Howard Place
Denver, Colorado 80204

Date RE:

FAX TO:		
COMPANY	CONTACT	FAX NUMBER
Public Service Company - Lighting	Cheri Weers	303-595-4577
Public Service Company Elec. Distribution	Clint Berry	303-571-7866
Public Service Company - Gas	Don Booton	303-571-3826
U.S. West Communications	Bill Reed	303-451-2579
AT & T Cable Services/TCI of Colorado	Eric Carroll	303-603-5980
MCI Telecommunications Corporation	Jesse Padilla	303-214-7130
US Sprint	Larry Schneidmiller	303-789-4867
Denver Water Department	Paul McQuade	303-628-6851
Denver Wastewater Management (Const/Insp)	Dave Willett	303-446-3589
Metro Wastewater Reclamation District	Ron Maring	303-286-3030
Burlington Northern and Santa Fe Railway		

The Preconstruction Conference for the above-referenced project will be held on[DATE AND TIME], [LOCATION]. The contract for this project has been awarded to [PRIME].

Please contact the Project Engineer or Resident Engineer at (XXX) XXX-XXXX

Sincerely,

Resident Engineer signature block

PRECONSTRUCTION CONFERENCE AGENDA

[CDOT CONSTRUCTION MANUAL AGENDA FORMS](#)

HOT MIX ASPHALT PRE-PAVING CONFERENCE AGENDA

The following is an example Hot Mix Asphalt Pre-paving Conference Agenda to assist in facilitating the meeting. This example presents a minimum set of topics that should be discussed during the Conference; however, not all topics will be covered for every project in every Region. Prior to its use, thoroughly read the Agenda's content and consider the special needs of the particular project and Region. Modify this agenda to meet the needs of your project. Copies of this Agenda are available from the CDOT website:

[CDOT CONSTRUCTION MANUAL AGENDA FORMS](#)

Contact the Area Engineer in the Contracts & Market Analysis Branch for additional information.

HOT MIX ASPHALT PRE-PAVE and PC/QA AGENDA

The items in the following agenda are minimum requirements that should be covered during the conference. The agenda may be used as is or as a base to develop a customized agenda. Personnel recommended to be in attendance are: Project Engineer, Paving Inspector, QA Tester, Region Materials Engineer, PC Tester, Superintendent, Paving Foreman, and Traffic Control Supervisor.

Project Number:		Resident Engineer:	
Sub Account:		Project Engineer:	
Location:		Contractor:	
Date:		Superintendent:	
Time:		Foreman:	

I. Project Personnel

A. Colorado Department of Transportation Personnel

1. CDOT Project Engineer:

Name:		Fax Number:	
Office Number:		Email Address:	
Cell Number:			

2. Assistant CDOT Project Engineer:

Name:		Fax Number:	
Office Number:		Email Address:	
Cell Number:			

3. Owner Acceptance Tester (QA Tester):

Name:		Fax Number:	
Office Number:		Email Address:	
Cell Number:			

4. Head Tester:

Name:		Fax Number:	
Office Number:		Email Address:	
Cell Number:			

5. Paving Inspector:

Name:		Fax Number:	
Office Number:		Email Address:	
Cell Number:			

6. Other

Name:		Fax Number:	
Office Number:		Email Address:	
Cell Number:			

7. Other

Name:		Fax Number:	
Office Number:		Email Address:	
Cell Number:			

Appendix A

B. Contractor Personnel

1. Superintendent

Name:		Fax Number:	
Office Number:		Email Address:	
Cell Number:			

2. Personnel to Notify at Paving Site:

Name:		Fax Number:	
Office Number:		Email Address:	
Cell Number:			

3. Process Control Supervisor:

Name:		Fax Number:	
Office Number:		Email Address:	
Cell Number:			

4. On Site Process Control Supervisor (if different from above):

Name:		Fax Number:	
Office Number:		Email Address:	
Cell Number:			

5. Process Control Tester (PC Tester)

Name:		Fax Number:	
Office Number:		Email Address:	
Cell Number:			

6. Other

Name:		Fax Number:	
Office Number:		Email Address:	
Cell Number:			

7. Other

Name:		Fax Number:	
Office Number:		Email Address:	
Cell Number:			

II. Attendance Roster

Name:		Office Number:	
Representing:		Fax Number:	
Address:		Cell Number:	
City, State, Zip:		Email Address:	
Name:		Office Number:	
Representing:		Fax Number:	
Address:		Cell Number:	
City, State, Zip:		Email Address:	
Name:		Office Number:	
Representing:		Fax Number:	
Address:		Cell Number:	
City, State, Zip:		Email Address:	

Appendix A

Name:		Office Number:	
Representing:		Fax Number:	
Address:		Cell Number:	
City, State, Zip:		Email Address:	
Name:		Office Number:	
Representing:		Fax Number:	
Address:		Cell Number:	
City, State, Zip:		Email Address:	
Name:		Office Number:	
Representing:		Fax Number:	
Address:		Cell Number:	
City, State, Zip:		Email Address:	
Name:		Office Number:	
Representing:		Fax Number:	
Address:		Cell Number:	
City, State, Zip:		Email Address:	
Name:		Office Number:	
Representing:		Fax Number:	
Address:		Cell Number:	
City, State, Zip:		Email Address:	
Name:		Office Number:	
Representing:		Fax Number:	
Address:		Cell Number:	
City, State, Zip:		Email Address:	
Name:		Office Number:	
Representing:		Fax Number:	
Address:		Cell Number:	
City, State, Zip:		Email Address:	
Name:		Office Number:	
Representing:		Fax Number:	
Address:		Cell Number:	
City, State, Zip:		Email Address:	
Name:		Office Number:	
Representing:		Fax Number:	
Address:		Cell Number:	
City, State, Zip:		Email Address:	

Appendix A

Name:		Office Number:	
Representing:		Fax Number:	
Address:		Cell Number:	
City, State, Zip:		Email Address:	
Name:		Office Number:	
Representing:		Fax Number:	
Address:		Cell Number:	
City, State, Zip:		Email Address:	
Name:		Office Number:	
Representing:		Fax Number:	
Address:		Cell Number:	
City, State, Zip:		Email Address:	
Name:		Office Number:	
Representing:		Fax Number:	
Address:		Cell Number:	
City, State, Zip:		Email Address:	
Name:		Office Number:	
Representing:		Fax Number:	
Address:		Cell Number:	
City, State, Zip:		Email Address:	
Name:		Office Number:	
Representing:		Fax Number:	
Address:		Cell Number:	
City, State, Zip:		Email Address:	
Name:		Office Number:	
Representing:		Fax Number:	
Address:		Cell Number:	
City, State, Zip:		Email Address:	
Name:		Office Number:	
Representing:		Fax Number:	
Address:		Cell Number:	
City, State, Zip:		Email Address:	

III. Escalation Process

A. Escalation Process - Discuss the escalation process for paving items. What is the chain of command and how/when issues are elevated to the next level in an effort to improve communication and decision making		
Comments:		
B. Form 626 Field Laboratory Test Results- Who is responsible for preparing, providing, and signing a Form 626 if required on the project.		
Owner Responsibility:		
Contractor Responsibility:		
C. Who will be the 3rd party, independent testing lab for dispute resolution? Has this been submitted in writing prior to the Pre -Pave Conference?		
Title	YES	NO
Asphalt Mix Dispute Lab:		
Roadway Smoothness Profiling:		
Comments:		
D. Discuss dispute split sampling requirements (per CP 17) and the different levels of the dispute resolution process (levels 1, 2, and 3)		
Comments:		

IV. Special Provision Requirements

A. Distribution of Section 105 and Section 106 of the Standard Specifications:		
<i>A minimum of the following personnel should have a copy of Section 105 and Section 106 of the Standard Specifications</i>		
Title	YES	NO
Project Engineer:		
Owner Acceptance Tester:		
Head Tester:		
Superintendent:		
Process Control Supervisor:		
Process Control Tester:		
B. Distribution of QC/QA Software:		
Which PC/QA Software is to be used on this project? :	Name:	Version:
<i>A minimum of the following personnel should have a copy of the QC/QA Software:</i>		
Title	YES	NO
Owner Acceptance Tester:		
Head Tester:		
Process Control Tester:		
<i>The following Project Special Provisions for Hot Mix Asphalt Pavement are reviewed and discussed below. Review the specifications associated with the project, determine what has been revised from the Standard Special Provisions and discuss each difference with the project staff.</i>		
C. Project Special Provision		
Comments:		
D. Project Special Provision		
Comments:		
E. Project Special Provision		
Comments:		
F. Project Special Provision		
Comments:		

V. Standard Special Provisions

The following Standard Special Provisions for Hot Mix Asphalt Pavement are reviewed and discussed below. Review the specifications associated with the project, determine what has been revised and discuss each difference with the project staff.

A. Standard Special Provision

Comments:

B. Standard Special Provision

Comments:

C. Standard Special Provision

Comments:

D. Standard Special Provision

Comments:

VI. Schedule

A. Materials

1. Materials will be available for sampling on:

Comments:

B. Asphalt Plant

1. The asphalt plant will be ready to be checked on:

a. The location of the plant to be used is:

b. What is the contingency plan if the designated plant breaks down?

Comments:

c. What type of Release Agent will be used?

Comments:

C. Scales and Certified Weigher:

1. Has a copy of the scale certification(s) been submitted?

YES:

NO:

Comments:

Appendix A

2. Has a copy of the weigher certification(s) been submitted?	YES:	NO:
Comments:		
3. Weigh tickets shall contain information required by the owner, as listed in section 109.01 of the Standard Specifications for Road and Bridge Construction. Is the Contractor's plant set up to print the tickets with the information required?	YES:	NO:
Comments:		
4. The Contractor shall provide a daily list of haul vehicles and required information per specification (CDOT subsection 109.01). Who will provide this to the Owner and who from the Owner's Agency will accept it from the Contractor?		
Comments:		
5. Random scale checks are required in the Standard Specifications (CDOT 109.01).		
Comments:		
D. Paving Schedule		
1. The Contractor will commence paving on:		
2. The paving equipment will be set up and ready to be checked on:		
3. How many days per week does the Contractor intend to work?		
4. What hours does the Contractor intend to work?		
5. Where will paving start?		
6. What width will be paved?		
7. What paving sequence will be followed?		
Comments:		
8. Are there any concerns with the phasing plan?		
Comments:		
9. Who should be notified if an asphalt truck is rejected?		
Comments:		
E. All Occupational Safety and Health Administration (OSHA) safety procedures must be followed. Discuss how the paving operation will be affected by OSHA requirements.		
Comments:		

Appendix A

F. What method will be used to determine pavement thickness?
Comments:
G. How does the Contractor and CDOT plan to address materials overruns?
Comments:
H. Other scheduling items that will affect the start of asphalt paving include:
Comments:

VII. Mix Design

A. Has the HMA Mix Design and CDOT Form 429 been submitted to the Owner?	YES:	NO:
Comments:		
B. Has the HMA Mix Design been reviewed by the Owner	YES:	NO:
Comments:		
C. Has the HMA Mix Design (CDOT Form 43) been issued by the Owner	YES:	NO:
Comments:		
D. Have the samples for CDOT acceptance testing been taken by the Contractor, and as appropriate, reduced to the size designated by the Project Engineer for compliance with CP-52?	YES:	NO:
Comments:		
E. The target values for Voids in Mineral Aggregates (VMA) will be established using the average of the first three volumetric field test results, or the target value specified in Table 403-2 of the <i>Standard Special Provisions</i>, whichever is higher.		
Comments:		
F. New VMA target values will be set whenever a new or revised mix design is used and production resumes.		
Comments:		

Appendix A

G. Have incidental items been verified with the Approved Products List?	YES:	NO:
Comments:		
H. No change shall be made to the ingredients comprising the approved mix design without prior written approval of the Project Engineer - this includes asphalt binder suppliers. Does the Contractor anticipate any changes needed at this time?	YES:	NO:
Comments:		

VIII. Check Testing Program

<p>A. When will check testing be performed? Note: Check testing shall be done prior to, or in conjunction with, placement of the first 500 tons of HMA. A check testing program will be conducted between acceptance testing and process control testing, per subsection 106.05 (c) of the <i>Standard Specifications</i> and compared to the acceptable limits shown in column 3 of Table 106-1 of the <i>Standard Specifications</i></p>
Comments:
<p>B. If production is suspended and then resumed, the Project Engineer may order a Check Testing Program between process control and acceptance testing personnel to assure the test results are within the permissible ranges. How with the Project Engineer notify the Contractor if this is required?</p>
Comments:

IX. Testing Requirements

A. How will test location be determined?		
Comments:		
B. Which daily Rice value will be used for compaction verification?	FIELD:	REGION:
Comments:		
<p>C. What is the frequency of testing to be performed? (Refer to table 106-1 of section 106.05 of the <i>Standard Specifications</i> for minimum sampling and testing for HMA)</p>		
Comments:		

Appendix A

<p>D. Are Quality Assurance tests to be performed in addition to Process Control tests? (All jobs including "M" projects greater than \$150,000 require testing). If yes, how often and who will be responsible to schedule the QA tests?</p>	<p>YES:</p>	<p>NO:</p>
<p>Comments:</p>		
<p>E. The turnaround time for test results for both QA and PC tests is immediately upon completion. Discuss any potential deviations from this requirement. What is the anticipated turnaround time?</p>		
<p>Comments:</p>		
<p>F. Split Samples: During production, split samples of randomly selected acceptance tests will be compared to the permissible ranges shown in <i>Field Materials Manual</i>, Colorado Procedure 13 (CP-13) Table 13-1. The minimum frequency will be as shown in Table 106-1 of the <i>Standard Special Provisions</i>.</p>		
<p>Comments:</p>		
<p>G. Reference Conditions: "Condition Red" reference condition requires the Contractor to be immediately notified as per subsection 106.05(c)(3) of the <i>Standard Special Provisions</i>. The minimum testing frequency will be increased to 1/250 tons until the Quality Level reaches or exceeds 78. If the Quality Level for the next five process control tests is below 65, production will be suspended. Is the Contractor familiar with the steps that must be taken to resume production and the testing to be performed when production is resumed?</p>		
<p>Comments:</p>		
<p>H. Lottman Retesting: If one or more samples fail to meet the requirements of Table 401-2, material from the area represented by the failing sample will be evaluated per Standard Specifications 401.02 (b)(2).</p>		
<p>Comments:</p>		

X. Production and Placement

<p>A. Compaction Test Section</p>
<p>1. The Contractor must establish a roller pattern and carefully record the following information. Who will be responsible from both the Owner and the Contractor to document and verify prior to paving continuance?</p>
<p>a. Type, size, amplitude, frequency, and speed of roller</p>
<p>b. Tire pressure for rubber tire rollers</p>
<p>c. For vibratory rollers, is it vibratory or static?</p>
<p>d. Surface temperature of mixture behind the lay-down machine and subsequent temperatures and densities after each roller pass.</p>
<p>e. Sequence and distance from lay-down machine for each roller and total number of passes of each roller to obtain specified density.</p>

Appendix A

Comments:		
<p>2. When a successful Compaction Test Section (CTS) has been completed, the Contractor is required to maintain the roller pattern established during the CTS for the balance of the HMA construction (i.e., the Contractor must use the same number and type of rollers and operate them at the same speed, frequency, amplitude, and in the same position, relative to the lay-down machine, as was performed during the CTS. If the Contractor wants to perform minor changes to the roller pattern that was established during the CTS, the Contractor must perform a Roller Pass Study to demonstrate that the density is obtained with the new roller pattern before proceeding with the paving operation. The Project Team needs to agree to the definition of "minor" at the prepave meeting. Minor changes may include items such as type of roller; numbers of rollers; distance from paver; number of roller passes; and temperatures.</p>		
Comments:		
<p>3. The Contractor is responsible for testing the compaction of the pavement in the Compaction Test Section. Who will be the contact for the Contractor for the testing?</p>		
Comments:		
<p>4. Cores are required to calibrate the nuclear density gauge. The Contractor can continue to pave under the following conditions:</p>		
<p>a. The period that the Contractor continues to pave without test results from cores shall not exceed one working day.</p>		
<p>b. Construction proceeds at the Contractor's risk.</p>		
Comments:		
<p>5. What method will be used to bulk core samples?</p>	<p>Traditional Method (CP 44, Method "B")</p>	<p>Core Dry</p>
<p>Process Control (PC)</p>		
<p>Quality Assurance (QA)</p>		
Comments:		
<p>6. A new Compaction Test Section or roller pass study will be required whenever there is a major change in the compaction process. The Project Team needs to agree to the definition of "major" at the prepave meeting. Major changes may include items such as: new mix design; change in lift thickness; or other items that could affect the nuclear density gauge correlations .</p>		
Comments:		

Appendix A

XI. Process Control Testing

A. Has the Contractor submitted their Process Control Plan?	YES:	NO:
Comments:		
B. Does the Process Control Plan, process control, project acceptance testing, and check testing frequencies meet the minimum random sampling frequency (Table 106-1 of the <i>Standard Specifications</i>)?	YES:	NO:
Comments:		
C. Is the Test Result Chart for each process, with tonnage and tolerance limits, posted daily at a location convenient for viewing by the Project Engineer?	YES:	NO:
Posting Location:		
Comments:		
D. Is the Quality Level Chart for each element in Table 106-1 of the <i>Standard Specifications</i> posted daily at a location convenient for viewing by the Project Engineer?	YES:	NO:
Posting Location:		
Comments:		
E. Is the Process Control Supervisor for process control sampling and testing identified in the Process Control Plan (PCP)?	YES:	NO:
Comments:		
F. Does the Process Control Supervisor possess one of the following qualifications? 1. Registration as a Professional Engineer in the State of Colorado 2. Level A, B, and C certifications from the Laboratory for Certification of Asphalt Technicians (LabCAT)	YES:	NO:
Comments:		
G. Do technicians taking samples and performing tests possess all of the following qualifications?		
1. Technicians taking samples and conducting compaction tests have Level A LabCAT certification?	YES:	NO:
2. Technicians conducting process control tests have Level B LabCAT certification?	YES:	NO:
3. Technicians determining mix volumetric and strength characteristics have Level C LabCAT certification?	YES:	NO:
Comments:		

Appendix A

H. Does the PCP provide information to control the quality of the following:		
1. Segregation	YES:	NO:
2. Longitudinal Joint Construction	YES:	NO:
3. Transverse Joint Construction	YES:	NO:
4. Smoothness	YES:	NO:
a. This project is:	Profiler (MRI):	
Comments:		
I. The Contractor will report the results of the process control tests to the Project Engineer in writing at least once per day. Where and when will this be performed?		
Comments:		
J. Has the Contractor's Process Control Plan been accepted and approved in writing by the Project Engineer?	YES:	NO:
Comments:		
K. Has the Contractor submitted the Contractor's Binder Field Quality Plan to ensure requirements of CP 11, Section 14 - Certifying Suppliers Providing Performance Graded Binders?	YES:	NO:
Comments:		

XII. Striping

A. Is the Subcontractor or Contractor installing the striping?	PRIME:	SUB:
Comments:		
B. When will striping occur?		
Comments:		
C. What material will be used?		
Comments:		
D. Have Materials Data Sheets been submitted? If so, have they been approved?	YES:	NO:
Comments:		

Appendix A

E. Has the striping plan been submitted? If so, has it been approved?	YES:	NO:
Comments:		

XIII. Traffic Control

A. Method of Handling Traffic (MHT):		
1. Has the MHT been submitted for the Hot Mix Asphalt Pavement placement operation?	YES:	NO:
If no, when will it be submitted?		
Comments:		
2. Has the MHT been submitted for the striping operation?	YES:	NO:
If no, when will it be submitted?		
Comments:		
3. Is the traffic control plan approved?	YES:	NO:
Comments:		

SUGGESTED BEST PRACTICES FOR MINIMIZING SEGREGATION

1. Aggregate Stockpiles:

- A. Build in Layers
 - B. Avoid any procedure that will allow the aggregate to be pushed or dumped over the side of a stockpile
- C. Separate to prevent intermingling
- D. Aggregate Handling:
 - i. Loader operator works full face of stockpile
 - ii. Install dividers on the “cold feed” bins to prevent the material from flowing into an adjacent bin
 - iii. DO NOT pile the aggregate so high it flows over the dividers

2. Loading the Surge Silo: (if the plant has a “batcher or “Gob Hopper” at the top of the silo)

- A. Adjust the conveying devices to deposit the material in the center of the batcher or gob hopper
- B. Keep the gates on the batcher or gob hopper closed unless dropping a load of mix
- C. Close the gate on the batcher or gob hopper before it is empty to prevent the material from dribbling into the silo

3. Loading Trucks

- A. Keep the gates on the bottom of the silo closed so the material does not dribble into the trucks
- B. Take care to center the trucks (left to right) when loading
- C. Load trucks in multiple drops with the first drop at the rear, second at the front and then alternate dumps
- D. If the mix is prone to segregation, you should avoid loading the trucks by “slowly” driving forward while dropping the mix from the silo

4. Dumping Trucks:

- A. To provide a surge of material to the paver, when using end dump type trucks, the box should be raised until the mix moves to the rear of the bed charging the tail gate prior to releasing the load
- B. If any mix is spilled on the roadway, in front of the paver while dumping the truck, the spilled mix should be removed from the roadway before the paver moves forward across the mixture on the grade

5. Laydown Operations:

- A. Only dump the wings on the paver hopper at the end of the paving day and utilize this material in the night taper joint or waste the material
- B. To provide consistent flow of material to the screed and avoid gradual deceleration/ acceleration, the paver should be started and stopped quickly at normal operating speed
- C. Keep the hopper more than half full at all times and maintain the height within 1 inch the entire paving day
- D. The auger height should be adjusted so the bottom of the auger is at least two (2) inches above the finished surface of the HMA mat
- E. Adjust the feed sensors to keep the material near the center of the auger at all times
- F. Correctly adjust the lead and tail crown of the screed so that the surface of the HMA behind the paver is uniform in appearance and texture
- G. Install or verify the material management kits are installed and functioning properly. This includes the “kick back” paddles under the gear box and outer edges of the auger
- H. Adjust the flow control; gates at the rear of the hopper so that:

Appendix A

- i. The slat conveyors run continuously
- ii. The amount of material being presented to the augers allows for them to run almost continually, (minimum of 80% of the time)

6. Windrow Elevators

- A. When using pickup machines they should be adjusted so that all of the HMA is removed from the surface

7. Troubleshooting

- A. If segregation is observed behind the paver, check the trucks as they arrive and are dumping to see if the mix in the truck is segregated
- B. The risk of causing thermal segregation is increased when paving in cooler temperatures

SUGGESTED BEST PRACTICES FOR PAVEMENT SMOOTHNESS

Paver Operations - Best Practices and Innovations

Keep the hopper full: If you are not using a hopper insert leave as much surge as possible between truck exchanges and do not run the hopper empty. This will minimize “truck fans” by allowing hot, uniform material from the next truck to blend with mix from the previous dump. Keeping your mat as thermally uniform as possible will result in better densities.

Controlled hopper wing cycling: The wings are where the large, cooler stone tends to collect if not properly reintroduced back to the mix. Regular cycling, where allowed by spec, will reduce large buildups of this segregated material. Don’t wait until you are “out of material” to cycle the wings

Use a hopper insert: If you are using pick up machines and windrow paving use a hopper insert. It will reduce or eliminate segregation.

Keep a constant head of material at the spreading augers: A consistent flow of material to the spreading augers will prevent them from spinning too fast or too slow, which can cause longitudinal segregation. As a rule of thumb, a proper head of material is ½ up the spreading auger. Constant changes in the head of material make waves in the mat. If allowed to rotate too fast, longitudinal stripes will occur in line with the reversing augers; too low a rate and the larger stone will drop and collect at the bearing support

Time the conveying and spreading systems: Ensure the ratio pots or flow gates are set to deliver enough material to the spreading augers to keep them running continuously. Set your sonic feeds and leave them there.

Keep your paver speed steady: Drag race paving may be entertaining but stops and starts cause the head of material to rise and fall changing the mat thickness. This not only affects ride but can detrimentally affect density.

Correct lead crown setting and proper strike off adjustment: Equipment fine-tuning issues will help eliminate longitudinal segregation. String line your screed before every job and introduce the correct amount of lead crown; usually 1/8 - 1/4 inches. Make sure your strike offs are correctly aligned. Refer to your owner’s manual for the recommended procedure.

Correct spread auger length: Once you have the job planned out if you need to build up the spreading augers then DO IT. Trying to compensate for spreading augers that are too short by running them faster will only result in segregation. This only gets worse with more gap graded mixes. If you have a 20’ screed and the job calls for wide paving then BUILD UP THE SCREED; use the auger extensions, wide mat grade supports and the outboard bearing supports. The finished jobs will more than compensate for the time involved in the buildup. Then plan the layout so you can maximize the use of the built-up screed.

Use Thermal guns: Equip your paver operator and roller hands with thermal (infrared) handheld thermometers and use them to monitor changes in the mat temperature. Establishment of a thermal range during the test strip process gives you a working range to be used throughout the paving project.

Don’t broadcast material across the mat: This just gives the appearance of a segregation problem. Don’t rake material off the joint onto the new mat. Don’t walk on the fresh mat.

Train your personnel: Not only in the operation of the equipment but in the art of reading mat defects. The sooner these defects are identified the sooner remedial action can be taken. Remember when the only tool you have is a hammer every problem looks like a nail.

Appendix A

Pave predominately uphill: On steep grades in mountainous terrain, pave uphill when possible. Control of material and speed of equipment is easier to maintain when paving uphill. Paving downhill may be problematic with paver and roller speeds. This may cause "ripples" in the mat that are difficult to remove. The mat may shove and tear more when operations proceed downhill, requiring patching or other undesired corrective work. QC should be onsite to monitor densities when steep grades require a change in the roller pattern.

NOTE: It is not intended to change the direction of the paving operation in rolling terrain. If the roadway grade is predominately in the uphill or downhill direction on mountain passes or other significant elevation changes, paving uphill provides a better product.

Job Set Up - Best Practices

Partnering: All personnel involved in the construction planning and design need to meet before the job so we can all "be on the same page" and resolve possible problems before they arise.

Pre Paving Planning Meeting: Meet with your crew every day to review the plan for the day's construction and expectations. Plan the truck route, plan the job layout, and assign people to required tasks.

Communication: Constant communication with all the elements of the paving process from design engineers to the lute man. This keeps all phases of the job on schedule and free of "Uh Oh's".

Mix Selection: Ensure the mix is of an adequate design for both strength and workability. Mind your temperatures.

Machine Maintenance: Not only does well maintained iron contribute to a more pleasant work environment it shows your people that you care enough about them to give them the best tools. It provides for a safer work environment and a more productive and profitable organization.

Smoothness-Thickness-Yield: The inspectors and field personnel need to be aware of the paving fundamental that yield, minimum thickness, and smoothness cannot be obtained at the same time.

Crew Training: Not only in the operation of the equipment but in the art of reading mat defects. The sooner these defects are identified the sooner remedial action can be taken. Remember when the only tool you have is a hammer every problem looks like a nail.

Know the Consequences: Of improperly operating the machines, improper principles and techniques of paving, rolling and trucking of poor safety awareness. Designate a "job site safety man" know the way to emergency medical care.

SUGGESTED BEST PRACTICES FOR LONGITUDINAL JOINT CONSTRUCTION

BE CONSISTANT: Decide on a plan and stick with it.

COMMIT TO A GOOD JOINT: Quality contractors build quality joints.

MAINTAIN A PROPER TAPER: Tapers range from near vertical to 12:1. Regardless of what taper is used, keep it consistent. Vertical edges and notches as vertical as possible. Keep edges confined as long as possible. Maintain a Proper “Head of Material”.

MAINTAIN PROPER OVERLAP: Keep overlap consistent typically from 0-1.5 inches. Place proper amount of HMA at the joint: Too little will allow water to enter the joint. Too much will cause a ridge which will carry water and interfere with compaction. **DO NOT RAKE THE JOINT!** If raking to correct improper amount of material, just bump the joint, **DO NOT BROADCAST** loose material across the mat.

USE PROPER ROLLING TECHNIQUES!

SUGGESTED BEST PRACTICES FOR BREAK DOWN ROLLER OPERATIONS

1. Communicate with paving crew and foreman for job requirements prior to the arrival of asphalt.
2. Confirm maintenance and water system checks – done on a daily basis to rollers.
3. Determine lift thickness – base or surface riding course.
4. Be aware of material temperature – at delivery to paver and behind screed.
5. Determine rolling drum mode – vibratory or static.
6. Make required amplitude adjustments both roller drums – depending on mix design, material thickness, and temperature zone.
7. Optimize water system controls – to avoid material pick-up and eliminate excessive water usage.
8. Establish proper rolling pattern – determined by paving width, roller drum width, unsupported edges, and drum overlap.
9. Determine rolling speed – to achieve proper impact spacing and meet smoothness requirements.
10. Monitor rolling temperature – and work within optimum temperature zones.
11. Make required rolling coverages – to achieve density requirements.
12. Adjust rolling operations – to satisfy density, smoothness, and production rates.
13. Maintain consistency throughout the entire shift.

SUGGESTED BEST PRACTICES FOR FINISH ROLLER OPERATION

1. Communicate – with paving crew, foreman and breakdown roller operator for job requirements.
2. Confirm maintenance and water system checks – done on a daily basis to rollers.
3. Be aware of material temperature – avoid “tender zone.”
4. Determine rolling drum mode – vibratory or static depending upon requirements to achieve density and smoothness.
5. Optimize water system controls – to avoid material pick-up and eliminate excessive water usage.
6. Establish proper rolling pattern, – determined by paving width, roller drum width, unsupported edges, and drum overlap.
7. Coordinate final rolling process with QA / QC personnel
8. Monitor rolling temperature – and work within optimum temperature zones.
9. Make required rolling coverage’s – to achieve density requirements and to remove drum edge marks.
10. Maintain consistency throughout the entire shift.

SUGGESTED BEST PRACTICES FOR PAVER OPERATORS

Safety operates the paver using "Best Practices" procedures, to produce the highest-quality pavement possible.

1. Select a paving speed that balances delivery, paver capacity and the compaction process and pave with few if any extended stops.
2. Work with screed operator in establishing and maintaining the head of material within a plus or minus one inch tolerance.
3. Steer the paver holding to a pre-determined reference.
4. Direct the truck driver to raise bed and exit when empty
5. Utilize rapid, but smooth start and stops to help prevent end-of-load roughness (if stopping is necessary.)
6. Observe HMA being discharged into paver hopper or insert for changes in characteristics of the mix.
7. Monitor paver for unusual noise or vibration (notify the proper person to take corrective actions).
8. Work with dump person to make sure truck does not bump paver, or let hopper run low.
9. Work as a team member.

PRE-DEMOLITION CONFERENCE AGENDA

The following is an example Pre-demolition Conference Agenda to assist in facilitating the meeting. This example presents a minimum set of topics that should be discussed during the Conference; however, not all topics will be covered for every project in every Region. Prior to its use, thoroughly read the Agenda's content and consider the special needs of the particular project and Region. Modify this agenda to meet the needs of your project. Copies of this Agenda are available from the CDOT website:

[CDOT CONSTRUCTION MANUAL AGENDA FORMS](#)

Contact the Area Engineer in the Contracts & Market Analysis Branch for additional information.

Appendix A

PRE-DEMOLITION CONFERENCE AGENDA

The items in the following agenda are minimum requirements that should be covered during the conference. The agenda may be used as is or as a base to develop a customized agenda.

Project Number:		Resident Engineer:	
Project Code (SA):		Project Engineer:	
Location:		Contractor:	
Date:		Superintendent:	
Time:		Foreman:	
I. Attendance Roster			
Name:		Office Number:	
Representing:		Fax Number:	
Street Address:		Cell Number:	
City, State, Zip:		E-Mail Address:	
Name:		Office Number:	
Representing:		Fax Number:	
Street Address:		Cell Number:	
City, State, Zip:		E-Mail Address:	
Name:		Office Number:	
Representing:		Fax Number:	
Street Address:		Cell Number:	
City, State, Zip:		E-Mail Address:	
Name:		Office Number:	
Representing:		Fax Number:	
Street Address:		Cell Number:	
City, State, Zip:		E-Mail Address:	
Name:		Office Number:	
Representing:		Fax Number:	
Street Address:		Cell Number:	
City, State, Zip:		E-Mail Address:	
Name:		Office Number:	
Representing:		Fax Number:	
Street Address:		Cell Number:	
City, State, Zip:		E-Mail Address:	
Name:		Office Number:	
Representing:		Fax Number:	
Street Address:		Cell Number:	
City, State, Zip:		E-Mail Address:	
Name:		Office Number:	
Representing:		Fax Number:	
Street Address:		Cell Number:	
City, State, Zip:		E-Mail Address:	

Appendix A

PRE-DEMOLITION CONFERENCE AGENDA (continued)			
I. Attendance Roster (continued)			
Name:		Office Number:	
Representing:		Fax Number:	
Street Address:		Cell Number:	
City, State, Zip:		E-Mail Address:	
Name:		Office Number:	
Representing:		Fax Number:	
Street Address:		Cell Number:	
City, State, Zip:		E-Mail Address:	
Name:		Office Number:	
Representing:		Fax Number:	
Street Address:		Cell Number:	
City, State, Zip:		E-Mail Address:	
Name:		Office Number:	
Representing:		Fax Number:	
Street Address:		Cell Number:	
City, State, Zip:		E-Mail Address:	
Name:		Office Number:	
Representing:		Fax Number:	
Street Address:		Cell Number:	
City, State, Zip:		E-Mail Address:	
Name:		Office Number:	
Representing:		Fax Number:	
Street Address:		Cell Number:	
City, State, Zip:		E-Mail Address:	
Name:		Office Number:	
Representing:		Fax Number:	
Street Address:		Cell Number:	
City, State, Zip:		E-Mail Address:	
Name:		Office Number:	
Representing:		Fax Number:	
Street Address:		Cell Number:	
City, State, Zip:		E-Mail Address:	
Name:		Office Number:	
Representing:		Fax Number:	
Street Address:		Cell Number:	
City, State, Zip:		E-Mail Address:	
Name:		Office Number:	
Representing:		Fax Number:	
Street Address:		Cell Number:	
City, State, Zip:		E-Mail Address:	

Appendix A

PRE-DEMOLITION CONFERENCE AGENDA (continued)			
II. Project Organization and Status			
A. Colorado Department of Transportation Personnel:			
1. Personnel in Charge at Site:			
Name/Title:		Fax Number:	
Office Number:		Home Number:	
Mobile Number:		E-Mail Address:	
2. Assistant-in-Charge (when personnel identified in A.1 is not present):			
Name/Title:		Fax Number:	
Office Number:		Home Number:	
Mobile Number:		E-Mail Address:	
3. Inspector/Duties:			
Name/Title:		Fax Number:	
Office Number:		Home Number:	
Mobile Number:		E-Mail Address:	
4. Inspector/Duties:			
Name/Title:		Fax Number:	
Office Number:		Home Number:	
Mobile Number:		E-Mail Address:	
5. Inspector/Duties:			
Name/Title:		Fax Number:	
Office Number:		Home Number:	
Mobile Number:		E-Mail Address:	
6.: Tester:			
Name/Title:		Fax Number:	
Office Number:		Home Number:	
Mobile Number:		E-Mail Address:	
7. Other:			
Name/Title:		Fax Number:	
Office Number:		Home Number:	
Mobile Number:		E-Mail Address:	
8. Other:			
Name/Title:		Fax Number:	
Office Number:		Home Number:	
Mobile Number:		E-Mail Address:	
Comments:			

Appendix A

B. Contractor Personnel:			
1. Project Superintendent:			
Name/Title:		Fax Number:	
Office Number:		Home Number:	
Mobile Number:		E-Mail Address:	
2. Demolition Company Superintendent:/Foreman			
Name/Title:		Fax Number:	
Office Number:		Home Number:	
Mobile Number:		E-Mail Address:	
3. Contractor's Engineer:			
Name/Title:		Fax Number:	
Office Number:		Home Number:	
Mobile Number:		E-Mail Address:	
4. Traffic Control Supervisor:			
Name/Title:		Fax Number:	
Office Number:		Home Number:	
Mobile Number:		E-Mail Address:	
5. Other:			
Name/Title:		Fax Number:	
Office Number:		Home Number:	
Mobile Number:		E-Mail Address:	

Appendix A

PRE-DEMOLITION CONFERENCE AGENDA (continued)	
III. Scheduling	
A. Demolition Schedule:	
1. Demolition is scheduled for:	
2. Anticipated duration of demolition:	
3. Detailed schedule complies with working hour restrictions?	
4. If all girders in any one span cannot be removed in a shift, how will the Contractor ensure stability of the remaining structure?	
5. If all spans of a multi span structure cannot be removed in a single shift, how will the Contractor ensure the stability of the remaining structure?	
B. Utilities:	
1. Has the Contractor verified that Power Lines will not interfere with demolition operations? Comments:	
2. Has the Contractor verified the location of underground utilities?	
C: Equipment Delivery:	
Demolition equipment will arrive at:	
D. Contractor's Engineer:	
1. The Contractor's Engineer shall inspect and provide written approval of each phase of demolition prior to allowing vehicles or pedestrians below or adjacent to the bridge. Comments:	
E. Other Scheduled Items:	
Other scheduling items that will affect the start of the demolition process include:	
1. Lighting necessary:	
2. Railroad Coordination:	
3. Utility Coordination:	
4. Agency Coordination:	
5. Other:	

PRE-DEMOLITION CONFERENCE AGENDA (continued)	
IV. Special Provision Requirements	
<i>The following Special Provisions are reviewed and discussed below:</i>	
A. Special Provision:	
Comments:	
B. Special Provision:	
Comments:	
C. Special Provision:	
Comments:	
D. Special Provision:	
Comments:	
E. Special Provision:	
Comments:	
F. Special Provision:	
Comments:	
G. Special Provision:	
Comments:	
H. Special Provision:	
Comments:	

Appendix A

PRE-DEMOLITION CONFERENCE AGENDA (continued)	
V. Plan Notes and Unusual Requirements	
<i>The following plan notes and unusual requirements, experimental features, research items, and other unusual requirements are reviewed and discussed below:</i>	
A. Plan Note:	Comments:
B. Plan Note:	Comments:
C. Plan Note:	Comments:
D. Plan Note:	Comments:
E. Other Requirement:	Comments:
F. Other Requirement:	Comments:
G. Other Requirement:	Comments:
H. Other Requirement:	Comments:

Appendix A

PRE-DEMOLITION CONFERENCE AGENDA (continued)	
VI. Pre-Demolition Inspections	
A. Falsework:	
1. Are falsework drawings required per section 202 of the Project Special Provisions?	
2. If falsework drawings are required, the Contractor's Engineer must certify in writing to the Project Engineer that falsework materials and construction are in conformance with the falsework drawings submitted to the Project Engineer prior to commencement of work, in accordance with subsection 601.11 of the <i>Standard Specifications</i> . Comments:	
VII. Demolition Plan and Procedures	
A. Demolition Plan:	
Has demolition plan been submitted as required? Comments:	
1. Have minimum requirements been incorporated into the demolition plan?	
a.	Removal Sequence?
b.	Equipment Descriptions?
c.	Temporary falsework, bracing and shoring?
d.	Protective covering details?
e.	Protection of live waterways?
i.	Turbidity?
ii.	Sedimentation?
iii.	pH?
iv.	Wetlands?
f.	Fugitive Dust Mitigation
g.	Dismantling, loading, and hauling details?
h.	Hazmat?
2. Plan stamped by Contractor's Engineer?	
3. Final plan to be submitted to Project Engineer on _____	

Appendix A

PRE-DEMOLITION CONFERENCE AGENDA (continued)	
B. Demolition Plan Deviation:	
If the Contractor is required to deviate from the demolition plan, prior approval from the Contractor's Engineer to make the revision must be discussed (i.e. schedule and related impacts) with the Project Engineer. Comments:	
C. Method of Communication:	
What method of communication will be used between the Contractor, the demolition subcontractor, the Contractor's Engineer, and the Project Engineer on the job site, during demolition? Comments:	
D. Weather :	
Does the Contractor have a contingency plan for inclement weather?	
The Contractor will confirm weather forecast 24 hours prior to demolition. Comments:	
IX. Safety Requirements	
A. Safety Plan:	
1. Has the Contractor provided for work site safety in accordance with the Occupational Safety and Health Administration requirements (e.g., hardhats, handrails, safety belts, nets)? Comments:	
2. Suggested safety topics:	
a. Appropriate equipment (type and size)?	
b. Never stand or walk under structure once demolition has begun.	
c. Do working hour limitations allow sufficient time for the Contractor's demolition sequence?	
3. Time and place of demolition safety meeting?	

X. Traffic Control
A. MHT
1. Will the equipment delivery require traffic control? Describe MHT
2. Will the debris removal require traffic control? Describe MHT
3. Will the demolition require traffic control? Describe MHT
4. Has the Method of Handling Traffic been submitted and approved?
5. Method to prevent traffic (vehicular and others) from entering workzone?
6. Public relations notified?
7. Verify vertical and lateral clearances after demolition and notify Staff Maintenance if necessary.
Additional comments:

PRE-ERECTION CONFERENCE AGENDA

The following is an example Pre-erection Conference Agenda to assist in facilitating the meeting. This example presents a minimum set of topics that should be discussed during the Conference; however, not all topics will be covered for every project in every Region. Prior to its use, thoroughly read the Agenda's content and consider the special needs of the particular project and Region. Modify this agenda to meet the needs of your project. Copies of this Agenda are available from the CDOT website:

[CDOT CONSTRUCTION MANUAL AGENDA FORMS](#)

Contact the Area Engineer in the Contracts & Market Analysis Branch for additional information.

Appendix A

PRE-ERECTION CONFERENCE AGENDA

The items in the following agenda are minimum requirements that should be covered during the conference. The agenda may be used as is or as a base to develop a customized agenda.

Project Number:		Resident Engineer:	
Project Code (SA):		Project Engineer:	
Location:		Contractor:	
Date:		Superintendent:	
Time:		Foreman:	
I. Attendance Roster			
Name:		Office Number:	
Representing:		Fax Number:	
Street Address:		Cell Number:	
City, State, Zip:		E-Mail Address:	
Name:		Office Number:	
Representing:		Fax Number:	
Street Address:		Cell Number:	
City, State, Zip:		E-Mail Address:	
Name:		Office Number:	
Representing:		Fax Number:	
Street Address:		Cell Number:	
City, State, Zip:		E-Mail Address:	
Name:		Office Number:	
Representing:		Fax Number:	
Street Address:		Cell Number:	
City, State, Zip:		E-Mail Address:	
Name:		Office Number:	
Representing:		Fax Number:	
Street Address:		Cell Number:	
City, State, Zip:		E-Mail Address:	
Name:		Office Number:	
Representing:		Fax Number:	
Street Address:		Cell Number:	
City, State, Zip:		E-Mail Address:	
Name:		Office Number:	
Representing:		Fax Number:	
Street Address:		Cell Number:	
City, State, Zip:		E-Mail Address:	
Name:		Office Number:	
Representing:		Fax Number:	
Street Address:		Cell Number:	
City, State, Zip:		E-Mail Address:	

Appendix A

PRE-ERECTION CONFERENCE AGENDA (continued)			
I. Attendance Roster (continued)			
Name:		Office Number:	
Representing:		Fax Number:	
Street Address:		Cell Number:	
City, State, Zip:		E-Mail Address:	
Name:		Office Number:	
Representing:		Fax Number:	
Street Address:		Cell Number:	
City, State, Zip:		E-Mail Address:	
Name:		Office Number:	
Representing:		Fax Number:	
Street Address:		Cell Number:	
City, State, Zip:		E-Mail Address:	
Name:		Office Number:	
Representing:		Fax Number:	
Street Address:		Cell Number:	
City, State, Zip:		E-Mail Address:	
Name:		Office Number:	
Representing:		Fax Number:	
Street Address:		Cell Number:	
City, State, Zip:		E-Mail Address:	
Name:		Office Number:	
Representing:		Fax Number:	
Street Address:		Cell Number:	
City, State, Zip:		E-Mail Address:	
Name:		Office Number:	
Representing:		Fax Number:	
Street Address:		Cell Number:	
City, State, Zip:		E-Mail Address:	
Name:		Office Number:	
Representing:		Fax Number:	
Street Address:		Cell Number:	
City, State, Zip:		E-Mail Address:	
Name:		Office Number:	
Representing:		Fax Number:	
Street Address:		Cell Number:	
City, State, Zip:		E-Mail Address:	
Name:		Office Number:	
Representing:		Fax Number:	
Street Address:		Cell Number:	
City, State, Zip:		E-Mail Address:	

Appendix A

PRE-ERECTION CONFERENCE AGENDA (continued)			
II. Project Organization and Status			
A. Colorado Department of Transportation Personnel:			
1. Personnel in Charge at Site:			
Name/Title:		Fax Number:	
Office Number:		Home Number:	
Mobile Number:		E-Mail Address:	
2. Assistant-in-Charge (when individual listed above is not present):			
Name/Title:		Fax Number:	
Office Number:		Home Number:	
Mobile Number:		E-Mail Address:	
3. Bridge Designer (attendance required):			
Name/Title:		Fax Number:	
Office Number:		Home Number:	
Mobile Number:		E-Mail Address:	
4. Staff Bridge (attendance as established by Project Engineer if bridge designed by Consultant):			
Name/Title:		Fax Number:	
Office Number:		Home Number:	
Mobile Number:		E-Mail Address:	
5. Inspector/Duties:			
Name/Title:		Fax Number:	
Office Number:		Home Number:	
Mobile Number:		E-Mail Address:	
6. Inspector/Duties:			
Name/Title:		Fax Number:	
Office Number:		Home Number:	
Mobile Number:		E-Mail Address:	
7. Inspector/Duties:			
Name/Title:		Fax Number:	
Office Number:		Home Number:	
Mobile Number:		E-Mail Address:	
8. Tester:			
Name/Title:		Fax Number:	
Office Number:		Home Number:	
Mobile Number:		E-Mail Address:	
9. Other:			
Name/Title:		Fax Number:	
Office Number:		Home Number:	
Mobile Number:		E-Mail Address:	
Comments:			

Appendix A

B. Contractor Personnel:			
1. Project Superintendent:			
Name/Title:		Fax Number:	
Office Number:		Home Number:	
Mobile Number:		E-Mail Address:	
2. Erection Company Superintendent/Foreman:			
Name/Title:		Fax Number:	
Office Number:		Home Number:	
Mobile Number:		E-Mail Address:	
3. Contractor's Engineer:			
Name/Title:		Fax Number:	
Office Number:		Home Number:	
Mobile Number:		E-Mail Address:	
4. Girder Fabricator (may attend by speaker telephone):			
Name/Title:		Fax Number:	
Office Number:		Home Number:	
Mobile Number:		E-Mail Address:	
5. Traffic Control Supervisor:			
Name/Title:		Fax Number:	
Office Number:		Home Number:	
Mobile Number:		E-Mail Address:	
6. Other:			
Name/Title:		Fax Number:	
Office Number:		Home Number:	
Mobile Number:		E-Mail Address:	

Appendix A

PRE-ERECTION CONFERENCE AGENDA (continued)	
III. Scheduling	
A. Materials:	
1. Girders will be delivered when (date and time)?	
2. Has the Quality Assurance Acceptance Report (Bridge Report #193) been received from the Staff Bridge Fabrication Inspector?	
3. If girders will be stored on site, describe storage and protection plan:	
4. Location of temporary storage if erection is postponed:	
5. What contingency plans are there for an interrupted delivery schedule?	
6. Has the pier cap concrete attained at least 80% of its 28 day strength (Subsection 601.11(e))?	
7. Project Engineer: When girders are delivered, who from the project will inspect for damage?	
B. Erection Schedule:	
1. Erection is scheduled for:	
2. Anticipated duration of erection:	
3. Detailed schedule complies with working hour restrictions?	
4. How will the Contractor stabilize the girders <u>during</u> and <u>after</u> erection operations?	
<p>Precast, Prestressed Concrete Box Girders (Bracing may not be required.):</p> <p>Precast, Prestressed Concrete I and BT Girders (Bracing may only be required during erection. Diaphragms will require installation as erection progresses.):</p> <p>Steel Girders: "No fewer than two steel girders shall be erected when girders are initially placed in any span, unless the Engineer provides a written waiver to this requirement." "Steel box girders need not be erected in pairs."</p>	
C. Crane Delivery:	
Crane(s) will arrive at:	
D. Contractor's Engineer:	
1. When a bridge spans traffic of any kind, the area beneath the girders shall not be opened to traffic until the Contractor's Engineer has inspected and provides written approval of the erected girders. Comments.	
2. Has the Contractor's Engineer provided the inspection form the Contractor will use to document the daily inspection of the erected girders and other permanent and temporary bridge elements?	
<i>Project Engineer: Who from the project has been assigned the task of inspecting the erected girders daily?</i>	

Appendix A

F. Other Scheduled Items:
Other scheduling items that will affect the start of the erection process include:
1. Lighting necessary:
2. Railroad Coordination:
3. Utility Coordination:
4. Other:
5. Other:
IV. Special Provision Requirements
<i>The following Special Provisions are reviewed and discussed below:</i>
A. Special Provision:
Comments:
B. Special Provision:
Comments:
C. Special Provision:
Comments:
D. Special Provision:
Comments:
E. Special Provision:
Comments:
F. Special Provision:
Comments:
G. Special Provision:
Comments:
H. Special Provision:
Comments:

PRE-ERECTION CONFERENCE AGENDA (continued)

V. Plan Notes and Unusual Requirements

The following plan notes and unusual requirements, experimental features, research items, and other unusual requirements are reviewed and discussed below:

A. Plan Note:

Comments:

B. Plan Note:

Comments:

C. Plan Note:

Comments:

D. Plan Note:

Comments:

E. Other Requirement:

Comments:

F. Other Requirement:

Comments:

G. Other Requirement:

Comments:

H. Other Requirement:

Comments:

Appendix A

PRE-ERECTION CONFERENCE AGENDA (continued)	
VI. Pre-Erection Inspections	
A. Bearings:	
1. Are bearings set on proper line and grade? Comments:	
2. Will the bearings be welded during erection? If so, welding must be performed by certified welder. Comments.	
B. Falsework:	
1. Is falsework required per subsection 601.11(a) of the <i>Standard Specifications</i> ?	
2. If falsework is required, has the Contractor's Engineer certified in writing that falsework materials and construction have been inspected and that all falsework design, materials, and construction conform with the requirements of the Contract and are safe for placement of loads, in accordance with subsection 601.11(b) of the <i>Standard Specifications</i> ? Comments:	
C. Substructure Survey 601.12(l)	
Has substructure survey been completed and submitted? Information checked against the plans and shop drawings?	
VII. Erection Plan and Procedures	
A. Erection Plan:	
Has erection plan been submitted as required? Comments:	
1. Have minimum requirements been incorporated into the erection plan?	
2. When will the final Erection Plan, signed and sealed by the Contractor's Engineer, stamped "Approved for Construction" and signed by the Contractor be submitted to the Project Engineer (date and time)?	
3. Erection subcontractor's demonstration of knowledge and familiarity with piece marks. <ul style="list-style-type: none"> - The Erection sheets from the shop drawings may be needed to facilitate the discussion. - Call the girder fabricator on the speaker telephone. <ul style="list-style-type: none"> • On the components to be erected, where are the piece marks located? • How are the piece marks oriented in the finished structure? • Discuss the shop drawing piece mark convention used by the girder fabricator. • Has the Erection subcontractor discussed with the fabricator how the girders will be loaded? Piece marks toward the front or rear of the truck? <p>Did the girder fabricator state whether the erection subcontractor had demonstrated a correct understanding of the piece marks?</p> <p>Did the girder fabricator correct any misunderstanding?</p>	

PRE-ERECTION CONFERENCE AGENDA (continued)
B. Erection Plan Deviation:
1. Any deviation from the final Erection Plan will require prior approval from the Contractor's Engineer and the Contractor and must be discussed with the Project Engineer. Comments:
2. What are the contingency plans if erection is not proceeding according to schedule? Based on production and time, what are the specific points during erection a decision will be made to proceed with or cancel erection? The decision must be discussed with the Project Engineer. Comments:
C. Method of Communication:
What method of communication will be used between the Contractor, the erection subcontractor, Contractor's Engineer, and the Project Engineer during erection?
D. Crane Operation:
1. Is the crane staging and erection site properly graded, drained, and stabilized? If not, when will it be?
2. Is there adequate room allowed for outriggers? Has the proximity to walls or other structures been investigated?
3. Has the Contractor verified the location of underground utilities in relation to the crane outriggers?
4. Has the Contractor verified that power lines will not interfere with crane operation? Comments:
5. What contingency plans are there for equipment failure? Comments:
E. Weather :
Does the Contractor have a contingency plan for inclement weather?
The Contractor will confirm weather forecast 24 hours prior to erection. Comments and description of contingency plan:
VIII. Inspection Requirements
A. Inspection of Bolts:
1. What "acceptable platform" will the Contractor provide to allow the Engineer to inspect tension in high strength bolts per subsection 509.28(h)?
2. The Contractor will need to demonstrate that the bolt tightening method used produces the tension specified in Table 509-3. Comments:

Appendix A

PRE-ERECTION CONFERENCE AGENDA (continued)	
IX. Safety Requirements	
A. Safety Plan:	
1.	Has the Contractor provided for work site safety in accordance with the Occupational Safety and Health Administration requirements and standard special provision, Project Safety Planning (e.g., hardhats, handrails, safety belts, nets)? Comments:
2.	Suggested safety topics: <ul style="list-style-type: none"> d. Properly sized crane? e. Appropriate slings, chokers, and lifting devices? f. Ensure that a single girder is tied off and braced prior to hoisting the adjacent girder. g. Tag lines to be used to control hoisted girders h. Never stand or walk under hoisted girder.
3.	Time and place of erection safety meeting?
X. Traffic Control	
A. Method of Handling Traffic (MHT)	
1.	Will the crane delivery require traffic control? Describe MHT
2.	Will the girder delivery require traffic control? Describe MHT
3.	Will the girder erection require traffic control? Describe MHT
4.	Has the Method of Handling Traffic been submitted and approved?
5.	Method to prevent traffic from entering work zone?
6.	Public relations notified?
7.	Verify vertical and lateral clearances after erection per subsection 630.09, Paragraph 4, (7) and (8). Staff Maintenance Permit Office may require notification. See Construction Bulletin 2006 Number 1..
Comments:	

STRUCTURAL CONCRETE PRE-POUR CONFERENCE AGENDA

The following is an example Structural Concrete Pre-pour Conference Agenda to assist in facilitating the meeting. This example presents a minimum set of topics that should be discussed during the Conference; however, not all topics will be covered for every project in every Region. Prior to its use, thoroughly read the Agenda's content and consider the special needs of the particular project and Region. Contact the Area Engineer in the Project Development Branch for additional information. Copies of this Agenda are available from the Project Development Branch and the CDOT Intranet and Internet Web Site.

The following is an example Pre-erection Conference Agenda to assist in facilitating the meeting. This example presents a minimum set of topics that should be discussed during the Conference; however, not all topics will be covered for every project in every Region. Prior to its use, thoroughly read the Agenda's content and consider the special needs of the particular project and Region. Modify this agenda to meet the needs of your project. Copies of this Agenda are available from the CDOT website:

[CDOT CONSTRUCTION MANUAL AGENDA FORMS](#)

Contact the Area Engineer in the Contracts & Market Analysis Branch for additional information.

Appendix A

STRUCTURAL CONCRETE PRE-POUR CONFERENCE AGENDA

The items in the following agenda are minimum requirements that should be covered during the conference. The agenda may be used as is or as a base to develop a customized agenda.

Project Number:		Resident Engineer:	
Project Code (SA):		Project Engineer:	
Location:		Contractor:	
Date:		Superintendent:	
Time:		Foreman:	
I. Attendance Roster			
Name:		Office Number:	
Representing:		Fax Number:	
Street Address:		Cell Number:	
City, State, Zip:		E-Mail Address:	
Name:		Office Number:	
Representing:		Fax Number:	
Street Address:		Cell Number:	
City, State, Zip:		E-Mail Address:	
Name:		Office Number:	
Representing:		Fax Number:	
Street Address:		Cell Number:	
City, State, Zip:		E-Mail Address:	
Name:		Office Number:	
Representing:		Fax Number:	
Street Address:		Cell Number:	
City, State, Zip:		E-Mail Address:	
Name:		Office Number:	
Representing:		Fax Number:	
Street Address:		Cell Number:	
City, State, Zip:		E-Mail Address:	
Name:		Office Number:	
Representing:		Fax Number:	
Street Address:		Cell Number:	
City, State, Zip:		E-Mail Address:	
Name:		Office Number:	
Representing:		Fax Number:	
Street Address:		Cell Number:	
City, State, Zip:		E-Mail Address:	
Name:		Office Number:	
Representing:		Fax Number:	
Street Address:		Cell Number:	
City, State, Zip:		E-Mail Address:	

Appendix A

STRUCTURAL CONCRETE PRE-POUR CONFERENCE AGENDA (continued)			
I. Attendance Roster (continued)			
Name:		Office Number:	
Representing:		Fax Number:	
Street Address:		Cell Number:	
City, State, Zip:		E-Mail Address:	
Name:		Office Number:	
Representing:		Fax Number:	
Street Address:		Cell Number:	
City, State, Zip:		E-Mail Address:	
Name:		Office Number:	
Representing:		Fax Number:	
Street Address:		Cell Number:	
City, State, Zip:		E-Mail Address:	
Name:		Office Number:	
Representing:		Fax Number:	
Street Address:		Cell Number:	
City, State, Zip:		E-Mail Address:	
Name:		Office Number:	
Representing:		Fax Number:	
Street Address:		Cell Number:	
City, State, Zip:		E-Mail Address:	
Name:		Office Number:	
Representing:		Fax Number:	
Street Address:		Cell Number:	
City, State, Zip:		E-Mail Address:	
Name:		Office Number:	
Representing:		Fax Number:	
Street Address:		Cell Number:	
City, State, Zip:		E-Mail Address:	
Name:		Office Number:	
Representing:		Fax Number:	
Street Address:		Cell Number:	
City, State, Zip:		E-Mail Address:	
Name:		Office Number:	
Representing:		Fax Number:	
Street Address:		Cell Number:	
City, State, Zip:		E-Mail Address:	
Name:		Office Number:	
Representing:		Fax Number:	
Street Address:		Cell Number:	
City, State, Zip:		E-Mail Address:	

Appendix A

STRUCTURAL CONCRETE PRE-POUR CONFERENCE AGENDA (continued)			
II. Project Organization and Status			
A. Colorado Department of Transportation Personnel:			
1. Personnel in Charge at Site:			
Name/Title:		Fax Number:	
Office Number:		Home Number:	
Mobile Number:		E-Mail Address:	
2. Assistant-in-Charge (when personnel identified in A.1 is not present):			
Name/Title:		Fax Number:	
Office Number:		Home Number:	
Mobile Number:		E-Mail Address:	
3. Tester:			
Name/Title:		Fax Number:	
Office Number:		Home Number:	
Mobile Number:		E-Mail Address:	
4. Inspector/Duties:			
Name/Title:		Fax Number:	
Office Number:		Home Number:	
Mobile Number:		E-Mail Address:	
5. Inspector/Duties:			
Name/Title:		Fax Number:	
Office Number:		Home Number:	
Mobile Number:		E-Mail Address:	
6. Inspector/Duties:			
Name/Title:		Fax Number:	
Office Number:		Home Number:	
Mobile Number:		E-Mail Address:	
7. Other:			
Name/Title:		Fax Number:	
Office Number:		Home Number:	
Mobile Number:		E-Mail Address:	
Comments:			
B. Contractor Personnel:			
1. Quality Control Supervisor:			
Name/Title:		Fax Number:	
Office Number:		Home Number:	
Mobile Number:		E-Mail Address:	
2. Other:			
Name/Title:		Fax Number:	
Office Number:		Home Number:	
Mobile Number:		E-Mail Address:	
3. Other:			
Name/Title:		Fax Number:	
Office Number:		Home Number:	
Mobile Number:		E-Mail Address:	
4. Other:			
Name/Title:		Fax Number:	
Office Number:		Home Number:	
Mobile Number:		E-Mail Address:	
Comments:			

Appendix A

STRUCTURAL CONCRETE PRE-POUR CONFERENCE AGENDA (continued)	
III. Scheduling	
A. Materials:	
Materials will be available for sampling on:	
B. Concrete Plant:	
Concrete plant will be ready to be checked on:	
C. Finishing Equipment:	
Finishing equipment will be set up and ready for approval on:	
D. Placement Schedule:	
Placement is scheduled for:	
E. Concrete Batching:	
Concrete batching will start at:	
F. Placement Location:	
Concrete placement will start at:	
G. Length of Pour:	
Anticipated length of pour:	
H. Other Scheduled Items:	
Other scheduling items that will affect the start of the concrete pour include:	
1.	
2.	
3.	
4.	

STRUCTURAL CONCRETE PRE-POUR CONFERENCE AGENDA (continued)	
IV. Special Provision Requirements	
<i>The following Special Provisions are reviewed and discussed below:</i>	
A. Special Provision:	
Comments:	
B. Special Provision:	
Comments:	
C. Special Provision:	
Comments:	
D. Special Provision:	
Comments:	
E. Special Provision:	
Comments:	
F. Special Provision:	
Comments:	
G. Special Provision:	
Comments:	
H. Special Provision:	
Comments:	

Appendix A

STRUCTURAL CONCRETE PRE-POUR CONFERENCE AGENDA (continued)	
V. Plan Notes and Unusual Requirements	
<i>The following plan notes and unusual requirements, experimental features, research items, and other unusual requirements are reviewed and discussed below:</i>	
A. Plan Note:	Comments:
B. Plan Note:	Comments:
C. Plan Note:	Comments:
D. Plan Note:	Comments:
E. Other Requirement:	Comments:
F. Other Requirement:	Comments:
G. Other Requirement:	Comments:
H. Other Requirement:	Comments:

Appendix A

STRUCTURAL CONCRETE PRE-POUR CONFERENCE AGENDA (continued)
VI. Pre-Pour Inspections
<i>The Contractor is hereby informed that no concrete shall be placed prior to review, inspection, and approval of the following items:</i>
A. Forms: Are forms set on proper line and grade, adequately supported, free of grout leaks, clean and properly sized. Comments:
B. Falsework: Are falsework drawings required per subsection 601.11(b) of the <i>Standard Specifications</i> ? If falsework drawings are required, the Contractor's professional engineer must certify in writing to the Project Engineer that falsework materials and construction are in conformance with the falsework drawings submitted to the Project Engineer prior to placement, in accordance with subsection 601.11(a) of the <i>Standard Specifications</i> . Comments:
Placement of telltales. Comments:
C. Reinforcing Steel: Reinforcing steel must be of the proper grade, and the bars must be of the correct number and size placed in the correct location. Bars must be properly tied and all areas where the epoxy coating has been damaged must be correctly repaired. Comments:
D. Expansion Devices: Expansion devices must be set on correct line and grade, formed and secured to allow concrete to flow around anchor devices with no resulting voids. Comments:
E. Line and Grade: Inspected for proper line and grade. Comments:
F. Finishing Machine and Testing Bridge: The finishing machine must be adjusted to finish on the proper line, grade, and skew, and the support rail or string line must be set properly and supported adequately. A test run must be completed and measurements taken to check uniformity. The testing bridge must be ready for use by CDOT forces. Comments:

Appendix A

STRUCTURAL CONCRETE PRE-POUR CONFERENCE AGENDA (continued)		
VII. Concrete Batching and Delivery (subsections 601.06 and 601.07)		
A. Plant and Truck Inspections:	Yes	No
Are plant and truck inspections current?		
Have CDOT Forms 46 – Concrete Truck Mixer Inspection Certification been submitted?		
Do all trucks have counters and manufacturer's plates that list the various drum speeds?		
Comments:		
B. Design Mix:	Yes	No
Has the Concrete Mix Design Report been reviewed and approved by the Materials and Geotechnical Branch?		
Are copies of the CDOT Mix Design Review Sheet available for supplier and Inspector?		
Are there any unusual features in the concrete mixes?		
Comments:		
C. Mix Deviation:	Yes	No
Does Contractor or supplier intend to deviate from proposed proportions for any reason (e.g., admixtures)?		
If yes, prior approval to make the revision must be received. Comments:		
D. Aggregate Stockpiles:	Yes	No
Have the fine and coarse aggregate stockpiles been tested for compliance with specifications?		
Are they adequate for the proposed placement?		
Will supplier sample aggregate stockpiles for moisture content within 24-hours prior to placement? These test results should be made available to the Inspector.		
Comments:		
E. Method of Communication:		
What method of communication will be used between the batch plant and the job site?		
F. Plant Breakdowns:	Yes	No
In the event of a plant breakdown, will an alternate plant be used?		
Has a mix design been approved for this alternate plant?		
Comments:		

STRUCTURAL CONCRETE PRE-POUR CONFERENCE AGENDA (continued)		
VII. Concrete Batching and Delivery (continued)		
G. Emergency Bulkheads:		
If it is necessary to place an emergency bulkhead, at what locations can this emergency bulkhead be placed?		
H. Bridge Design and Management Branch:		
Has the Bridge Design and Management Branch been contacted for advice?	Yes	No
Comments:		
I. Concrete Tests:		
The Contractor is reminded that the concrete will be tested at the job site. The results of these tests will be used to accept, price reduce, or reject the concrete. The Project Engineer, or his delegated representative, will be responsible for informing the Contractor of the test results and the acceptability of the concrete. Comments:		
J. Concrete Rejection:		
The Contractor is reminded that concrete can be rejected for any of the following reasons:		
1. mix exceeds the water-cement ratio criteria,		
2. mixing/hauling exceed specified time limit,		
3. work is not meeting specified concrete mix temperatures, or		
4. a batch ticket is not filled out completely.		
Comments:		
K. Batch Tickets:		
The concrete supplier is to furnish a batch ticket with each load of concrete delivered to the project. These tickets must contain all the information specified in subsection 601.06 of the Standard Specifications. The Contractor shall collect and complete the batch ticket at the placement site and deliver all batch tickets to the Project Engineer on a daily basis as per subsection 601.06 of the Standard Specifications. Comments:		

Appendix A

STRUCTURAL CONCRETE PRE-POUR CONFERENCE AGENDA (continued)		
VIII. Concrete Placement (subsection 601.12 and 601.15)		
A. Weather (see subsection 601.12 (b) and (c) for temperature limitations):	Yes	No
Does the Contractor have a contingency plan for inclement weather?		
What is the weather forecast for the proposed placement date? Comments:		
B. Placement Method:		
What is the Contractor's method of placement, and what other method will be used in the event of breakdowns?		
C. Form and Reinforcement Prewetting:		
What method will be used to prewet forms and reinforcing steel?		
D. Placement Sequence:	Yes	No
Is the placement sequence approved?		
Comments:		
E. Special Controls:	Yes	No
Is special control required to prevent detrimental camber deflections or girder rotation?		
Comments:		
1. F. Construction Joints:		
If construction joints are needed, where will they be placed?		
G. Vibrators:	Yes	No
Have frequency checks been performed on the vibrators?		
Will backups be available?		
How many vibrators and generators will be used?		
The Contractor is reminded that the vibrators shall not be used to move the concrete. Comments:		

Appendix A

STRUCTURAL CONCRETE PRE-POUR CONFERENCE AGENDA (continued)		
IX. Concrete Finishing (subsections 601.12(k), 601.14, and 601.15)		
A. Finishing Equipment:		
What is the Contractor's plan in the event of a mechanical breakdown of the finishing machine?		
B. Straightedge:		Yes
Is a 10-foot straightedge available for checking the tolerances of the finished concrete?		No
Comments:		
2. C. Thickness and Cover Checks:		
The Contractor is reminded that slab thickness and reinforcing steel cover checks will be made continuously and that the Contractor may be required to adjust the screed periodically or refinish a portion of the slab to within tolerance. Comments:		
D. Addition of Water:		
The Contractor is cautioned that applying water to in-place concrete by any method other than those permitted by the Contract will result in the rejection of placed concrete. Comments:		
E. Waterproofing Membrane:		Yes
Will the deck be covered with a waterproofing membrane? OR		No
Will the final surface be concrete?		
Comments:		

Appendix A

STRUCTURAL CONCRETE PRE-POUR CONFERENCE AGENDA (continued)		
X. Concrete Curing (subsections 601.13 and 601.16)		
A. Curing Method:		
What method of curing will the Contractor use?		
B. Timing of Curing:		
When will the curing method begin and how long will it last?		
C. Protection of Concrete:		Yes
Does Contractor have equipment and materials at the site to provide insulation/heating of the concrete?		No
Comments:		
XI. Safety Requirements		
		Yes
Has the Contractor provided for work site safety in accordance with the Occupational Safety and Health Administration requirements (e.g., hardhats, handrails, safety belts, nets)?		No
Comments:		
XII. Traffic Control		
		Yes
Will the concrete placement require traffic control?		No
Has the Method of Handling Traffic been submitted and approved prior to placement?		
Comments:		

CONCRETE PAVEMENT PRE-PAVING AND QC/QA CONFERENCE AGENDA

The following is an example Concrete Pavement Pre-paving and QC/QA Conference Agenda to assist in facilitating the meeting. This example presents a minimum set of topics that should be discussed during the Conference; however, not all topics will be covered for every project in every Region. Prior to its use, thoroughly read the Agenda's content and consider the special needs of the particular project and Region. Modify this agenda to meet the needs of your project. Copies of this Agenda are available from the CDOT website:

[CDOT CONSTRUCTION MANUAL AGENDA FORMS](#)

Contact the Area Engineer in the Contracts & Market Analysis Branch for additional information.

[A-6_CONCRETE PAVEMENT PRE-PAVING AND QCQA CONFERENCE AGENDA.PDF]

ENVIRONMENTAL PRECONSTRUCTION CONFERENCE AGENDA AND ATTENDANCE ROSTER

The following is an example Environmental Preconstruction Conference Agenda and an Attendance Roster (with Certification of Understanding) to assist in facilitating the meeting. This example presents a minimum set of topics that should be discussed during the Conference; however, not all topics will be covered for every project in every Region. Prior to its use, thoroughly read the Agenda's content and consider the special needs of the particular project and Region. Modify this agenda to meet the needs of your project. Copies of this Agenda are available from the CDOT website:

[CDOT CONSTRUCTION MANUAL AGENDA FORMS](#)

Contact the Area Engineer in the Contracts & Market Analysis Branch for additional information.

ENVIRONMENTAL PRE-CONSTRUCTION CONFERENCE AGENDA

1. Introductions

	Name	Phone number	Email Address
Project Engineer			
Superintendent			
Contractor's SWMP Administrator			
Supervisors or Foremen			
RWPCM			
CDOT SWMP Preparer or Reviewer			

2. Purpose of the Environmental Pre-construction Conference

- To discuss the terms and conditions of the Stormwater Management Plan (SWMP). Review the regulatory enforcement mechanisms outlined in 208.09 Failure to Perform.
- Project site review.
- At the conclusion of the Environmental Preconstruction Conference, each attendee is required to sign the Certificate of Understanding acknowledging that they understand the terms and conditions of the SWMP and the Permit. Any other individuals that comes onto the project site during construction (including sub-contractors and suppliers) shall also be made aware of these requirements and they are required to sign the Certification of Understanding. This Agenda and the Certification of Understanding must be included in Tab 15 of the SWMP Notebook.

3. Concept, Goal and Compliance

- Basic concept is that stormwater runoff caused by precipitation is OK. It's the pollutants collected in the runoff as it is conveyed through our construction site that is the problem.
- Our goal is to contain, reduce or eliminate the pollution to the stormwater runoff that is caused by the project's construction activities be it grading, paving, painting, or simply where we park our vehicles and dispose of our trash.
- This project has a Permit from the Colorado Department of Public Health and Environment (CDPHE). Under this Permit, facilities are granted authorization to discharge stormwater associated with construction activities into State waters of Colorado; however, there are regulatory requirements that we need to comply with to protect water quality as defined in the Permit.

- The SWMP must include a description of all stormwater management controls that will be implemented as part of the construction activity to control pollutants in stormwater discharges such as sediment, chemicals and trash.
- The Contractor is responsible for making their own determination as to the adequacy and locations of BMP types, and shall amend the SWMP in accordance with Section 208.

4. Project Start Date

- Prior to construction the Region Water Pollution Control Manager (RWPCM) and the contractor's SWMP Administrator shall:
 - Evaluate the project site for stormwater draining into or through the site.
 - Evaluate the project site for non-stormwater coming onto the site.
 - Review existing inlets and determine if protecting is needed.
 - Review and identify sensitive habitats on site, wetlands and other vegetation (including trees) to be protected.

The anticipated start of construction is:

5. Inspections

- **7-day and post-storm event inspections** by the SWMP Administrator and Erosion Control Inspector (if required), Superintendent and Project Engineer per specification 208.03 (c) 2.
 - **Headquarter and Region water quality inspections** performed by the RWPCM per CDOT's Municipal Separate Storm Sewer System (MS4) permit. Attendees can include the RWPCM, the Project Engineer, the Superintendent, SWMP Administrator and Erosion Control Inspector (ECI) (if needed). Inspections with aforementioned representatives will perform an audit of the SWMP notebook and a MS4 compliance site inspection. The concept of these inspections is to initially assess each project for their level of environmental risk to adversely impact State waters, and then continually reassess the project's performance throughout the duration of the project. Environmental risk is based upon factors such as proximity to State waters, amount of acres of disturbance, type of project, soil classification, slopes and type of "findings" identified during the inspection. The findings identified in the inspection that need to be corrected must be documented within ESCAN.
- **Local Jurisdictional and Qualifying Local Program inspections** may also be required per Part 1, A.1 of the Permit unless a waiver or other agreement has been made.

6. Failure to Perform Erosion Control

- Failure to implement the SWMP is a violation of the Permit and CDOT specifications. Penalties will be assessed to the Contractor by the appropriate

agencies. Any penalties (including monetary fines) assessed to the Department for the Contractor's failure to implement the SWMP will be deducted from moneys due the Contractor in accordance with subsection 107.25 (c) 2. See subsection 208.09 for further information about notifying Contractor for incidences of failure to perform, liquidated damages, and stop work orders.

- **First Engineer Response** – The Engineer will provide immediate verbal notification to Contractor accompanied by a Form # 105 to the Contractor requiring immediate compliance with the Permit. The Contractor has 48 hours from 11:59 p.m. of the day the Form 105 was issued to complete the work. Compliance must be documented by a reply to the Form 105 of the corrected items. Documentation must be submitted to the Engineer by the following business day after the 48 hour period.
- **Second Engineer Response** – If required work is not completed within 48 hours of the issued Form 105, the Engineer will assess the appropriate liquidated damages. Liquidated damages will continue to accumulate for each calendar day until all corrections are completed as stipulated under revised subsection 208.09.
- **Third Engineer Response** – If the Contractor fails to correct compliance failures within 48 hours without acceptable justification, once liquidated damages are applied, the Engineer will issue a Stop Work Order in accordance with subsection 105.01.
- **Fourth Engineer Response** – If the Contractor's deferment request including the corrective action plan and schedule are not submitted within 96 hours of the initial notice, the Engineer will schedule an on-site meeting with the Resident Engineer, RWPCM, Superintendent, SWMP Administrator, and the Superintendent's supervisor.
- **Fifth Engineer Response** – If the Contractor remains non-responsive to requirements of the on-site meeting, the Engineer will start default and Contract termination procedures in accordance with section 108.8 of the Construction Manual.

The Contractor's deferment request shall be in writing and include the specific failure, temporary measures until final correction is made, the methodology which will be employed to make the correction and interim milestones to completing the work. The Region Water Pollution Control Manager (RWPCM), Engineer, the SWMP Administrator and the Contractor shall concur on this deferral and set a proposed date of completion. Based on the submittal date of the approved deferment Liquidated Damages and a Stop Work Order may not be mandated to the Contractor.

When a failure meets any one of the following conditions, the Engineer may immediately issue a Stop Work Order in accordance with subsection 105.01 irrespective of any other available remedy:

- It may endanger health or the environment.

- It consists of a spill or discharge of hazardous substances or oil which may cause pollution of the waters of the state.
- It consists of a discharge of stormwater which may cause an exceedance of a water quality standard.

7. Key Submittals

- SWMP Notebook will be provided to the Contractor at the time of the Environmental Pre-construction Conference. Notebook is and shall remain the property of CDOT. The notebook will be stored in the CDOT field office or at another on-site location approved by the Engineer. Notebook will include the first 4 items per specification 208.03 (d) 1:
 1. SWMP Plan Sheets.
 2. SWMP Site Map(s) and Project Plan Title Sheet.
 3. Copies of subsection 107.25, and Sections 207, 208, 212, 213, and 216 of the Standard Specifications, and the standard and project special provisions that modify them.
 4. Standard Plan M-208-1, M-216-1 and M-615-1.
- Certification that the contractor's appointed SWMP Administrator and ECI (if needed) has completed the Transportation Erosion Control Supervisor (TECS) training program. The SWMP Administrator and ECI shall be a person other than the Superintendent. The SWMP Administrator shall be responsible for developing, implementing, maintaining and revising the SWMP for the duration of the project.
- "Spill Response Plan" completed prior to the Environmental Pre-construction Conference. Work shall not be started until the plan has been submitted to and approved by the Engineer. Specification 107.25 (b) 6 and 208.06 (c).
- "List of Potential Pollution Sources" completed prior to the environmental preconstruction conference per specification 107.25 (b) 6.
- "Method Statement for Containing Pollutant Byproducts" statement submitted to the Engineer a minimum of ten days prior to the start of the construction activity per specification 107.25 (b) 13.
 - "Clean Equipment Certification" submitted to the Engineer that construction equipment has been cleaned prior to initial site arrival. Vehicles shall be free of soil and debris. Specification 107.25 (b) 20.
 - "Construction Dewatering Permit" (CDW) prior to dewatering operations (if any) per specifications 106.02 (b) and 107.25 (b) 8.
 - Written notification to downstream owners of water supply at least 15 days prior to dredging or fill operations (if any) per specification 107.25 (b) 9.
- Soil Retention Blankets (Subsection 216.02): A sample of the staples and a copy of the manufacturer's product data showing that the product meets the Contract requirements shall be submitted to the Engineer for approval.

8. SWMP Notebook:

This is for the SWMP Administrator to update and revise as needed. Read all areas prior to the start of construction to make sure they are correct and apply to this project.

208.03 (d) The following Contract documents and reports shall be kept, maintained, and updated in the notebook by the SWMP Administrator:

- (1) SWMP Plan Sheets - Notes, tabulation, sequence of major activities, area of disturbance, existing soil data, and existing vegetation percent cover, potential pollutant sources, receiving water, non-stormwater discharges and environmental impacts.
- (2) Site Map and Plan Title Sheet - Construction site boundaries, ground surface disturbance, limits of cut and fill, flow arrows, structural BMPs, non-structural BMPs, Springs, Streams, Wetlands and surface water. Also included on the sheets is the protection of trees, shrubs and cultural resources.
- (3) Specifications - Standard and Project special provisions related to Stormwater and Erosion Control.
- (4) Standard Plans M-208-1, M-216-1 and M-615-1
- (5) BMP Details not in Standard Plan M-208-1 or M-216-1 (Non-standard details).
- (6) Weekly meeting sign in sheet.
- (7) Calendar of Inspections -Calendar of inspections marking when all inspections take place.
- (8) Form 1176, Weekly meeting notes and inspection report
- (9) Region and Headquarter Water Quality Reports and Form 105(s) relating to Water Quality.
- (10)Description of Inspection and Maintenance Methods -
- (11)Spill Response Plan - Reports of reportable spills submitted to CDPHE
- (12)List and Evaluation of Potential Pollutants -
- (13)Other Correspondence e.g., agreements with other MS4s, approved deferral request, CDPHE audit documentation, Water Quality Permit Transfer to Maintenance Punch List and other miscellaneous documentation.
- (14)TECS Certifications of the SWMP Administrator and all ECIs, keep current through the life of the project.
- (15)Environmental Pre-construction Conference – Conference agenda with a certification of understanding of the terms and conditions of the CDPS-SCP and SWMP.
- (16)All Project Environmental Permits - All project environmental permits and associated applications and certifications, including, CDPS-SCP, Senate Bill 40, USACE 404,temporary stream crossings, dewatering, biological opinions and all other permits applicable to the project, including any separate CDPS-SCP obtained by the Contractor for staging area on private property, asphalt or concrete plant, etc.
- (17)Photographs Documenting Existing Vegetation –
- (18)Permanent Water Quality Plan Sheets - Plan sheets and specifications for permanent water quality structures, riprap.

CDOT CONSTRUCTION MANUAL

APPENDIX B. EXAMPLE NOTICES, LETTERS, AND FORMS

Appendix B

APPENDIX B. EXAMPLE NOTICES, LETTERS, AND FORMS.....	B-1
EXAMPLE LETTERS, NOTICES, AND FORMS.....	B-4
Sample Acceptance Letter	B-5
Sample Buy America Certification.....	B-6
Sample Summary of Buy America Quantities	B-8
Sample Buy America Certification with Exceptions.....	B-10
Sample Stockpiled Material Letter of Vested Interest.....	B-13
Sample Prompt Payment Notice	B-14
Sample Prompt Payment Law Notice	B-15
Form 7 - Weekly Report on Miscellaneous Pay Items	B-16
Form 10 - Inspector's Report for Force Account Work	B-20
Billing Example: Contractor Bill to CDOT	B-24
Billing Example: Subcontractor Bill to Contractor	B-25
Form 46 - Concrete Truck Mixer Inspection Certification.....	B-26
Form 103 - Project Diary	B-28
Form 105 - Speed Memo	B-31
Form 200 - OJT Training Questionnaire	B-34
Form 262 - Weekly Time Count Report - Work Days	B-36
Form 263 - Weekly Time Count Report - Calendar Days	B-39
Form 266 - Inspector's Progress Report	B-42
Form 279 - Inspector's Report of Reinforcing Steel Placed.....	B-46
Form 280 - EEO and Labor Compliance Verification	B-49
Form 282 - Asphalt Paving Inspector's Daily Report	B-51
Form 568 - CDOT Temporary Speed Limit Reduction	B-54
Form 580 - Equipment Rental Rate Determination Request	B-59
Form 832 - Trainee Status and Evaluation	B-63
Form 838 - OJT Trainee/Apprentice Record.....	B-66
Form 859 - Project Control Data	B-69
Form 1186 - Contract Funding Increase/Decrease and Approval Letter	B-78
Form 1212 - Final Acceptance Report	B-81
Form 1318 - Dispute and Claim Status Report	B-85
FHWA Form 1391 - Federal-Aid Highway Construction Contractors Annual EEO Report...	B-89

Appendix B

Form 1401 - Block Faced MSE Wall Submittal Checklist.....	B-91
Form 1402 - Panel Faced MSE Wall Submittal Checklist.....	B-93
Piling Form.....	B-94
Traffic Control Review Form	B-97
Project Final Submittal Checklist	B-105
CPM Schedule Review Checklists	B-110

EXAMPLE LETTERS, NOTICES, AND FORMS

Appendix B presents examples of the most common letters, notices, and forms (i.e., CDOT Forms, FHWA Forms) Project Engineers and Project Inspectors will be involved with on a day-to-day basis. The Contractor may be responsible for submitting some items. The completion of other items will be the responsibility of either the Project Inspector or the Project Engineer. Regardless, the Project Engineer is responsible for ensuring the items are properly reviewed and distributed.

Completion instructions are provided for each form example presented in Appendix B. See Appendix C for guidance on preparing change orders (i.e., Form 90 and Form 94).

Most of the forms are self-explanatory. Computer generated forms will be accepted if they contain the exact verbiage and statute references.

CDOT Forms are available on the CDOT Forms Catalog Web Site <https://www.codot.gov/library/forms>, and FHWA Forms are available at

<https://www.fhwa.dot.gov/eforms/>.

Sample Acceptance Letter

STATE OF COLORADO

DEPARTMENT OF TRANSPORTATION

Loveland Residency
2207 East Highway 402
Loveland, CO 80537
Phone: 303-750-7436



May 26, 2013

Acme Industries
Attn: Mr. Superintendent
1707 Copper Road
Golden, CO 80401

Project # ES4 0253-206
I-25 Rubblization N of SH 34
Project Code 17167

Subject: Final Acceptance

Gentlemen,

The Colorado Department of Transportation has accepted your Project ES4 0253-206, I-25 Rubblization North of State Highway 34, as of May 26, 2013. A final inspection has been made and the work found acceptable to the Department of Transportation as of the close of business on May 25, 2013. A total 426.5 days of a planned 460 calendar days of Time Count were used.

Please remove any remaining signs, materials or equipment from the project. Please submit the following items as soon as possible to expedite final payment and release of any retainage.

Acme Industries:

- Form 17, Certificate listing all MBE's that engaged in this contract and report the full dollar amount paid to each.
- Buy America certification compliance letter for steel pipe used in storm drain.
- FHWA Form 47.
- COC for emulsified asphalt quantities from 3/10/2013 through completion of the project.
- Response on concrete price adjustment for tensioned cable barrier, see Form 105 dated January 26, 2013.
- Truck tare sheet for ABC (Cl. 6) (Special) for 5-20-13.
- Certified Invoice for purchase of Pavement Sensors, once these have been delivered as per Form 105 of 5/5/11.
- Payrolls for weeks ending 5-15-13, 5-22-13, and 5-29-13. On the final week's payroll, please indicate "**Final Payroll**".

Ready-to-Roll Traffic Control:

- Payrolls for weeks ending 5-15-13, 5-22-13, and 5-29-13.

Heavy Duty Construction Company:

- COC's for 7-foot wooden guardrail posts.
- Payrolls for weeks ending 5-15-13 and 5-22-13.

Highway Safety Services, Inc.:

- Payrolls for weeks ending 5-15-13 and 5-22-13.

AAA Land Surveyors:

- Final survey billing and the field books, stamped.

Semi-final estimate quantities are attached. You have two weeks to review these documents, after which time all quantities will be final. Please contact Adam Brown at 303-123-4567 if you have any questions concerning the final estimate.

Acme Industries can be proud of this major effort toward meeting the transportation needs of Northern Colorado. Thank you very much for your effort and cooperation.

Sincerely,

John Smith,
Project Engineer

cc: Region 4 Finals Engr. Region 4 Program Engr. Loveland Resident Engr.
Contracts & Market Analysis Projects and Grants Region 4 Traffic
Materials & Geotech Br. Region 4 Materials Engr. Region 4 Business Office
Region 4 Area Engr. Proj. File R-4 Maintenance Supt. Region 4 EEO

Sample Buy America Certification

The specification requires the Contractor to certify that he has obtained all the correct certifications from the manufacturers and suppliers and maintain the certifications on file at the project. These Buy America certifications are to be received and approved by CDOT before the materials are incorporated into the project. Once the Contractor receives the Buy America certification from manufacturers and suppliers, the Contractor shall provide CDOT with a Buy America certification such as the example below. CDOT does not accept blanket Buy America letters covering all materials.

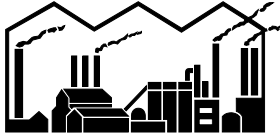

Kryptonite Construction Inc.
13369 W. Rocky Rd.
Smallville, Colorado 91130
Phone: 999-123-4567

Attn: Project Engineer

Date: August 3, 2018

Re: CDOT Contract ID: 53124

Re: CDOT Project: No. CC 00-0000-00

Subject: Buy America Certification and Exception for Foreign Steel

Kryptonite Construction hereby certifies that during the month of July 2018 the materials and quantities represented below, to be incorporated into the project, meet the contract Buy America requirements. We also certify that the Buy America paperwork and certifications required by Section 106.11 are on file at the project.

1) 550 LF of 24" culvert pipe for bid item 603-01180

Minor Exceptions: ___ Yes ___X No

Value less than 1/10 of 1% of the total contract cost or \$ 2,500.00 whichever is greater.

Documentation is in our Project Files.

Respectfully,

Clark Kent
Construction Manager
Kryptonite Construction Inc.

EXAMPLE

Buy America Requirements

(Per requirements of Subsection 106.11)
(Original Signatures Required, No Facsimiles Accepted)

Note 1: The Contractor shall submit the Buy America Certification to the Project Engineer at time materials are delivered and prior to incorporating the steel or iron into the project.

Note 2: The delivery date and/or the incorporation date may be included in the letter.

Note 3: This example depicts what is to be provided for each delivery.

Sample Summary of Buy America Quantities

This is a suggested format for the reconciliation of the Buy America Certification quantities with Installed Quantities. The Contractor shall submit this summary on a monthly basis to the Project Engineer for material incorporated during the previous month. The Project Engineer will verify the information in the Summary and all Buy America certifications provided by the Contractor. Before approving a progress payment, the Resident Engineer will verify that the quantities in the Contractor's summary document match the quantities in the progress payment.



Kryptonite Construction Inc.

Summary of Buy America Certifications Received for Installed Steel / Iron Products

CDOT Project No.: CC000-000-00

CDOT Contract ID: 53124

Summary for the Period Ending: July 2018

Item	Item Description	Delivery Date	Quantity Delivered to Project	Unit	Delivered Cost *	BUY AMERICA CERTIFICATION Quantity	Installed Quantity	Unit	Installation Month	BUY AMERICA CERTIFICATION Date
603-01180	24" culvert pipe	11-Jul-18	550	LF		550	300	LF	July	9-Jul-18
						550	250	LF	August	9-Jul-18
Total	603-01180 24" culvert pipe		550	LF			550	LF		

Prepared by: *Clark Kent* Title: _____ Construction Manager Date: August 3, 2018

* If there is any foreign steel or iron permanently incorporated into the project the Contractor shall provide documentation of the project delivered cost of that foreign steel or iron.

EXAMPLE

Suggested format for the reconciliation of the Buy America Certification quantities with Installed Quantities. The Contractor shall submit this summary to the Project Engineer.

Subsection 4.1.G "The Contractor shall maintain a document summarizing the date and quantity of the material utilizing CDOT Item Number(s) and Item Description(s) delivered to the project, along with the quantity of material installed during the month."

CLARIFICATION: This summary example indicates that the Period Ended in October. The Buy America Certification date is from July 9th and the Delivery Date is from July 11th. This example document summarizes the quantity delivered along with the quantity installed.

Note: This example depicts what is to be provided monthly summarizing delivery and installation.

Sample Buy America Certification with Exceptions

The specification requires the Contractor to document the project delivered costs of any foreign steel or iron permanently incorporated into the project. This is an example of the requirement.

Appendix B

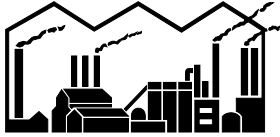

Kryptonite Construction Inc.
13369 W. Rocky Rd.
Smallville, Colorado 91130
Phone: 999-123-4567

Attn: Project Engineer

Date: October 4, 2018

Re: CDOT Contract ID: 53124

Re: CDOT Project No.: CC 00-0000-00

Subject: Buy America Certification & Exception for Foreign Steel

Kryptonite Construction hereby certifies that during the month of September 2018 the materials and quantities represented below, to be incorporated into the project, meet the contract Buy America requirements. We also certify that the Buy America paperwork and certifications required by Section 106.11 are on file at the project.

1) 150 LF of 24" culvert pipe for bid item 603-01180

Minor Exceptions: Yes No

Value less than 1/10 of 1% of the total contract cost or \$ 2,500.00 whichever is greater.

Documentation is in our Project Files.

1) 16 panels of ADA Truncated Domes which were imported from China were incorporated into the project. The total contract cost to date of imported steel or iron is \$1,831.66.

Respectfully,

Clark Kent
Construction Manager
Kryptonite Construction Inc.

<p>EXAMPLE</p> <p><u>Buy America Requirements</u></p> <p>(Per requirements of Subsection 106.11) (Original Signatures Required, No Facsimiles Accepted)</p>

Note 1: The Contractor shall submit the Buy America Certification to the Project Engineer at time materials are delivered and prior to incorporating the steel or iron into the project.

Note 2: The delivery date and/or the incorporation date may be included in the letter.

Note 3: This example depicts what is to be provided for each delivery.



Kryptonite Construction Inc.

Summary of Buy America Certifications Received for Installed Steel / Iron Products

CDOT Project No.: CC000-000-00

CDOT Contract ID: 53124

Summary for the Period Ending: September 2018

Item	Item Description	Delivery Date	Quantity Delivered to Project	Unit	Delivered Cost *	BUY AMERICA CERTIFICATION Quantity	Installed Quantity	Unit	Installation Month	BUY AMERICA CERTIFICATION Date
603-01180	24" culvert pipe	25-Sep-18	150	LF		150	150	LF	September	21-Sep-18
608.02.03.00	ADA Trunc Dome, 2x3	27-Sep-18	16	EA		0	16	EA	September	

Prepared by: Chad R. King Title: Construction Manager Date: October 4, 2018

* If there is any foreign steel or iron permanently incorporated into the project the Contractor shall provide documentation of the project delivered cost of that foreign steel or iron.

EXAMPLE

Suggested format for the reconciliation of the Buy America Certification quantities with Installed Quantities. The Contractor shall submit this summary to the Project Engineer.

Subsection 4.1.G "The Contractor shall maintain a document summarizing the date and quantity of the material utilizing CDOT Item Number(s) and Item Description(s) delivered to the project, along with the quantity of material installed during the month."

CLARIFICATION: This summary example indicates that the Period Ended in September. A Buy America Certification was not provided for the embedded type ADA Truncated Dome panels of a dimension of 2' x 3' each. This summary example correlates to the Buy America Certification & Exception for Foreign Steel document on the preceding page.

Note: This example depicts what is to be provided monthly summarizing delivery and installation.

Sample Stockpiled Material Letter of Vested Interest

To Whom It May Concern: _____

Re: Stockpiled Material Letter of Vested Interest

It is hereby understood that the Colorado Department of Transportation fully intends to reimburse _____
(Contractor - Purchaser)

for materials owned by said Contractor - Purchaser and intended for incorporation into Colorado Department of Transportation Project No. _____

Said materials, as described below, are now stored on property owned by _____
_____ and leased by _____
(if applicable)

Said storage property is located as follows:

(Address and/or Description of Property)

Said stored materials are described as follows:

(Detailed Description of Materials)

It is hereby recognized that once reimbursement has been accomplished, the Colorado Department of Transportation will have a vested interest in the materials. Access to and possession of the materials will be granted to the Colorado Department of Transportation upon demand and providing that acceptable proof is offered substantiation that reimbursement to the named Contractor - Purchaser was in fact, accomplished.

_____ Owner	_____ Phone Number	_____ Lessee (if applicable)	_____ Phone Number
_____ Owner	_____ Phone Number	_____ Lessee (if applicable)	_____ Phone Number

Attachments: (when existing)

Warehouse Receipt of Contract for Storage

This letter is a legal document, must be original, and must clearly identify the materials wither in the body or by specifically identifiable attachments.

Sample Prompt Payment Notice

PROMPT PAYMENT Notice to all subcontractors and suppliers

The Colorado Department of Transportation (CDOT) is committed to the principle that all members of the construction team are entitled to prompt payment for work properly performed. It is CDOT's intention to work in partnership with all Contractors, Subcontractors, and Suppliers to improve the prompt payment of all parties involved in CDOT contracts.

This notice is provided to explain to all parties how CDOT makes payments for work in progress.

PARTIAL PAYMENTS

Monthly Partial Payments. The Prime Contractor will be paid based on estimates prepared by the Engineer. The Prime Contractor establishes the estimate cut-off date at the Preconstruction Conference. This date is used for estimating the partial payment of work performed through that date. CDOT does not require the Prime Contractor to bill for normal contract work other than force account or stockpiled materials.

Delayed Partial Payments. The Engineer shall notify the Prime Contractor, in writing, of the reason for any delay to a partial payment. All Prime Contractor requests to delay a partial payment to permit inclusion of a specific amount of work shall be made in writing. The Prime Contractor shall notify each Subcontractor who has performed work during the payment period of the reason for the delay.

Copies of Partial Payment Estimates. The Project Engineer will provide the Prime Contractor with a copy of all monthly partial payment estimates. The Prime Contractor should provide a copy of the monthly estimate to each Subcontractor that has performed work during the period covered by the estimate. If the Contractor requires the Subcontractor to bill for their work the Subcontractors may need the quantities of work paid by CDOT to prepare their billing. The Subcontractors should get a copy of the monthly estimate from the Prime Contractor. CDOT will assist Subcontractors in obtaining a copy of the monthly estimate. Copies of the monthly estimate may be found at the following website:

<http://www.coloradodot.info/business/payestimates>

Electronic Funds Transfer (EFT). The Prime Contractor can authorize CDOT to electronically transfer funds. Forms are available from Accounts Payable by calling 303-757-9569 or 303-757-9996. Funds are normally available in 4 to 5 days after the Resident Engineer authorizes the estimate. Funds are immediately available after the deposit is made via EFT. With EFT, the Contractor avoids waiting on the mail and does not have to deposit the warrant.

3/23/10

Sample Prompt Payment Law Notice

PROMPT PAYMENT LAW

Standard Specification section 109.06(a) requires all Contractors to comply with the existing Prompt Payment Law (CRS 24-91-103(2)). This law requires the Contractor to pay all Subcontractors within seven days providing the Subcontractor complies with the Prompt Payment law. Failure by the Contractor to comply with the prompt payment law may be reason to debar the Contractor.

The citation for Colorado's Prompt Payment Act is 24-91-103(2), C.R.S. (1991), relating to public works. Following is an exact quote:

(2) Whenever a contractor receives payment pursuant to this section, the contractor shall make payments to each of his subcontractors of any amounts actually received which were included in the contractor's request for payment to the public entity for such subcontracts. The contractor shall make such payments within seven calendar days of receipt of payment from the public entity in the same manner as the public entity is required to pay the contractor under this section if the subcontractor is satisfactorily performing under his contract with the contractor. The subcontractor shall pay all suppliers, sub-subcontractors, laborers, and any other persons who provide goods, materials, labor, or equipment to the subcontractor any amounts actually received which were included in the subcontractor's request for payment to the contractor for such persons, in the same manner set forth in this subsection (2) regarding payments by the contractor to the subcontractor. If the subcontractor fails to make such payments in the required manner, the subcontractor shall pay said suppliers, sub-subcontractors, and laborers interest in the same manner set forth in this subsection (2) regarding payments by the contractor to the subcontractor. At the time the subcontractor submits a request for payment to the contractor, the subcontractor shall also submit to the contractor a list of the subcontractor's suppliers, sub-subcontractors, and laborers. The contractor shall be relieved of the requirements of this subsection (2) regarding payment in seven days and interest payment until the subcontractor submits such list. If the contractor fails to make timely payments to the subcontractor as required by this section, the contractor shall pay the subcontractor interest as specified by contract or at the rate of fifteen percent per annum whichever is higher, on the amount of the payment which was not made in a timely manner. The interest shall accrue for the period from the required payment date to the date on which payment is made. Nothing in this subsection (2) shall be construed to affect the retention provisions of any contract.

Form 7 - Weekly Report on Miscellaneous Pay Items

Completion Instructions

Use Form 7 to document daily quantities for miscellaneous pay items such as dozing, blading, roller, wetting, flagging, traffic control supervision, pilot car, and trainee. See Section 120 and Section 121.2.1 of this *Manual* for additional information. Complete Form 7 as follows:

1. Project No., Project Code (SA#), and Location. *Fill in as appropriate.*
2. Week Ending. *Enter month, day, and year of the last day represented by the Form 7 being completed.*
3. Calendar Day. *Enter the month and day for each day of the week represented by the Form 7 being completed.*
4. Reference No. and Item No. *Enter the appropriate Computer Reference Number and Item Number for the items not listed on Form 7.*
5. Description. *Enter a description of the added item.*
6. Unit. *Enter the unit of measurement for the added item.*
7. Daily Quantities. *Enter the item quantity for each day. The person that is preparing Form 7 will determine the daily quantities. The following additional information may be useful in determining quantities:*
 - a. Traffic Control Supervision Diaries,
 - b. Form 20 - Daily Water Report, and
 - c. Project Diaries.
8. Weekly Total. *The weekly total is the sum of the daily quantities.*
9. Previous Total. *Provide the total to date from the previous Form 7.*
10. Total to Date. *The total to date is the sum of the weekly total (#8) and the previous total (#9).*
11. Remarks. *Note any unusual or special conditions that may clarify this week's quantities. Additional space is available on the second page of Form 7.*
12. Signature and Title. *Signature and title of the person completing Form 7.*

Appendix B

13. *Checked By. Must be signed or initialed and dated by the person who checked the calculations and quantities on Form 7. This check must be performed by an individual other than the person who determined the quantities. This check should be completed in accordance with Section 121 of this Manual.*
14. *Posted By. Must be signed or initialed and dated by the person who transferred the total quantity from Form 7 to Daily Work Report in SiteManager®.*
15. *Contractor's Representative Signature. The Contractor is not required to sign and date the completed Form 7, but it is a best management practice to get the Contractor to agree to the quantities on a weekly basis.*
16. *Sequential No. Enter the sequential number of the Form 7. Start with number one and continue sequentially numbering each Form 7 throughout the project.*

COLORADO DEPARTMENT OF TRANSPORTATION
WEEKLY REPORT ON MISCELLANEOUS PAY ITEMS

Project No.: C.00XX-00XX
Location: 2 Miles North of SH XX

Project Code (SA#): XXXX
Week Ending: 7/XX/XX

Ref. No.	Item No.	Desc	Date	7-X							Weekly Total	Previous Total	Total To Date		
				Unit	Sun	Mon	Tue	Wed	Thu	Fri				Sat	
	203	Backhoe	hour	6									8	9	10
	203	Blading	hour		3										
	203	Potholing	hour												
	250	Monitoring Technician	hour												
	250	Health & Safety Officer	hour												
	630	Flagging*	hour												
	630	UTC	hour												
	630	TCM*	day												
	630	TCI*	day												
	630	Pilot Car*	hour												
	630	Portable Message Sign	day												
165	900	Trainee	hour		7								25.5	102.5	128.0
		Construction Surveying	hour												
		Trainee	hour												

*Final quantities for these items shall be determined on a weekly basis in conformance with the Standard Special Provision - REVISION OF SECTION 630 - CONSTRUCTION ZONE TRAFFIC CONTROL.

Ref. No.	Truck No.	Capacity	Daily Meter Reading or Load Count							M3 (M-Gal) Totals				
			Sun	Mon	Tue	Wed	Thu	Fri	Sat	Weekly	Previous			

Remarks:

Signature: *Stuart Anderson* Title: CEPMI Date: / / Checked By: / / Date: / /

Posted By: *Angus McGee* Date: / / Date: / /

Distribution: Project File (original) CDOT Form 7 05/10

Form 10 - Inspector's Report for Force Account Work

Completion Instructions

The documentation requirements presented in Section 120 of this *Manual* should be reviewed before using Form 10. Complete Form 10 as follows:

1. Project No., Project Code (SA#), and CMO or F/A No. Enter the project number, project code, and CMO or F/A number.
2. Contractor's Name, Subcontractor's Name, and Description of Work. Enter the Contractor and subcontractor names, and provide a description of the work.
3. Date. Enter the dates when the force account work was performed. The dates need not be consecutive.
4. Employee Name, Occupation, and Hours. Enter the employee name, occupation, and number of hours worked. The Project Inspector must check the payrolls against the billing and Form 10 data and then sign and date the Form 10.
5. Equipment Code No. and Rate. Equipment code numbers and rental rates shall be as listed on Form 580 - Equipment Rental Rate Determination Request. Completion instructions for Form 580 are included in Appendix B.

The Contractor must submit a certified invoice for rental equipment.

If the rental equipment was used for bid item work as well as force account work, the portion of the rental cost that will be paid for on force account shall be determined by prorating the total number of hours the equipment was operated to the number of hours it was operated on the force account work.

If the rental agreement does not include operating costs, hourly operating costs shall be calculated in accordance with the Rental Rate Blue Book for Construction Equipment. The Blue Book hourly operating costs will be paid for the actual hours that the equipment was used on the force account work. The hourly operating cost calculation can be shown on the rental invoice.

In accordance with subsection 109.04 of the Standard Specifications, an additional 10 percent of the total rental cost, including operating cost, will be added to the Contractor's payment.

6. Material. List all material used for the force account work.

Appendix B

7. Contractor/Subcontractor Initials. The Contractor representative shall initial the Form 10 daily. For subcontract work, the initials of the subcontractor who performed the force account work and the Prime Contractor's initials must be shown.
8. Signature and Title. The Project Inspector of the force account work must sign and date the Form 10.

Other items that require review include:

- a. Use of correct wage rates and fringe benefits per payrolls.
 - i. If a State-funded project, the Contractor will need to furnish a copy of the payroll for rate verification.
 - ii. If a specialty firm, a certified invoice that may include wages, etc., is required.
- b. 67 percent loading applied to wage rates including fringe benefits when paid directly to the employee.
- c. Check the mathematics. Minor errors can be corrected. Copy the Contractor on corrected billings.
- d. Materials invoices must be certified in accordance with Section 120 of this Manual.
- e. The Contractor's force account billings must be reviewed and approved by the Project Engineer prior to authorizing payments and submittal to the Region for final checking. Sample billings follow the Form 10 example.

COLORADO DEPARTMENT OF TRANSPORTATION INSPECTOR'S REPORT FOR FORCE ACCOUNT WORK	Project No.: NH1111-111 <hr/> Project Code (SA#): ① 99999 <hr/> CMO or F/A No.: CMO #2
--	---

Contractor's Name: Jones Excavating, Inc. ②
Subcontractor's Name: N/A
Description of Work: Repair Bridge Approach

LABOR Employee Name	Occupation	Date:												Total Hours		
		10/21/13		10/23/14		10/24/13		10/25/13		/ /						
		ST	OT	ST	OT	ST	OT	ST	OT	ST	OT	ST	OT			
Dean Flynn	Foreman	4		4		4								12		
Bob Walsh	Operator	4		4		4			2					14		
Gus Peck	Trucki Driver					4								4		
Jose Lopez	Laborer	3		3		3			1					10		

The hours shown here were checked against the certified payrolls. Checked By: *Alex Dubois* Date: 11/04/13

EQUIPMENT Code No.	Shift		Rate	Hours												Total Hours		
	1 st	SB		ST	OT	ST	OT	ST	OT	ST	OT	ST	OT					
Hyd. Tamper - Rental			Invoice															
Tandem 04429	x												4					
04850	x					2												
04862	x							3										

MATERIAL Type	Unit	Number of Units												Total Units			
Note: A Certified Invoice for Materials is required as part of billing.																	

Contractor/Subcontractor Initials ⑦ *DFI DFI DFI DFI* 1

Billing procedures shall conform to applicable project specifications.
 I certify that this is a correct record of employee & equipment hours and material units on the above project as authorized by the above modification order or agreement.
 Signed: *Bill Lindsay* ⑧ Title: *EIT-I*

Distribution: Region Finals Engineer (original) CDOT Form 10 07/02
 Project File
 Contractor Previous editions may be used until supplies exhausted

COLORADO DEPARTMENT OF TRANSPORTATION INSPECTOR'S REPORT FOR FORCE ACCOUNT WORK	Project No.: NH 1111-111 Project Code (SA#): 99999 1 CMO or F/A No.: CMO #2
--	---

Contractor's Name: Jones Excavating, Inc.
Subcontractor's Name: Smith Construction Company 2
Description of Work: Repair Bridge Approach

LABOR 4 Employee Name	Occupation 3	Date:										Total Hours	
		10/21/13		10/23/13		10/24/13		10/25/13		/ /			
		ST	OT	ST	OT	ST	OT	ST	OT	ST	OT	ST	OT
David Sands	Operator	4				4	2					8	2
Jim Strong	Laborer	3		2	1			3	1			8	2
John Palmer	Laborer	2		3	1			3	1			8	2
Sam Hill	Truck Driver					4	2					4	2

The hours shown here were checked against the certified payrolls. Checked By: *Alex Dubois* Date: 11/04/13

EQUIPMENT Code No. 5	Shift		Rate 5	Hours								Total Hours	
	1 st	SB		ST	OT	ST	OT	ST	OT	ST	OT		
Demo Saw (Small tool)	x		2.00			2		2					4
Tandem 02184	x		38.80			4			6				10
Backhoe 04294	x		73.25						6				6
Carbon Steel Saw Blade - used 50%			Invoice										

MATERIAL Type 6	Unit	Number of Units				Total Units
Note: A Certified Invoice for Materials is required as part of billing.						
HMA	Ton				42	42

Contractor/Subcontractor Initials 7 *DFIQC DFIQC DFIQC DFIQC* 1

Billing procedures shall conform to applicable project specifications.

I certify that this is a correct record of employee & equipment hours and material units on the above project as authorized by the above modification order or agreement.

Signed: *Bill Lindsay* 8 Title: *EIT-I*

Distribution: Region Finals Engineer (original) Project File Contractor CDOT Form 10 07/02

Previous editions may be used until supplies exhausted

Billing Example: Contractor Bill to CDOT

CONTRACTOR LETTERHEAD

<p>To: Colorado Department of Transportation 4201 East Arkansas Avenue Denver, CO 80222 Attn: Alex White Project Engineer</p>	<p>Re: NH1111-111/ 99999 CMO #2 Repair Bridge Approach</p>
---	--

Billing for force account work performed on 10/21/13 through 10/25/13:

Labor:

Foreman 12 hrs @ 480.00/wk	\$144.00
Operator 14 hrs @ 14.10	197.40
Truck driver 4 hrs @ 13.36	53.44
Labor 10 hrs @ 10.50	<u>105.00</u>
Total Labor	\$499.84

Equipment:

Hyd. Tamper rental @invoice	\$112.90
Plus Rental Rate Overhead (10% of 112.90)	11.29
Tandem 04429 4 hrs @ 34.65	138.60
04850 2 hrs @ 5.95	11.90
04862 3 hrs @ 8.45	<u>25.35</u>
Total Equipment	\$300.04

Fringe Benefits:

Operator 14 hrs @ 3.2	\$44.80
Truck driver 4 hrs @ 2.64	10.56
Labor 10 hrs @ 2.59	<u>25.90</u>
Total Fringe Benefits	\$81.26

Summary (Total this billing)

Labor	\$499.84
+67% Labor	334.89
Equipment	300.04
Fringe Benefits	81.26
+67% Fringe Benefits	54.44
Billings from Subcontractor	3,540.97
Admin. Loading per 109.04(e)	<u>227.05</u>
TOTAL BILLING	\$5,038.49

Attachments:

Billing and invoice from Subcontractor
 Certified invoices (materials and equipment rentals)

Billing Example: Subcontractor Bill to Contractor

SUBCONTRACTOR LETTERHEAD

To: Contractor Re: NH1111-111/ 99999
CMO #1
Repair Bridge Approach

The following is our bill for doing work in October 2013:

Labor:

Operator 8 hrs @ 14.10	\$112.80
Operator 2 hrs @ 21.15	42.30
Labor 2 employees @ 8 hrs @ 10.50	168.00
Labor 2 employees @ 2 hrs @ 15.75	63.00
Truck driver 4 hrs @ 13.36	53.44
Truck driver 2 hrs @ 20.04	<u>40.08</u>

Total Labor \$479.62

Equipment:

Demo saw @ \$2.00 (small tool rate) 4 hrs	\$8.00
Tandem 01284 10 hrs @ \$38.80	388.00
Backhoe 04294 6 hrs @ \$73.25	439.50
Carbon steel saw blade @ agreed 50% invoice	175.00
Loading on fast-use expendable parts (109.04(c)9)	<u>\$17.50</u>

Total Equipment \$1028.00

Material:

Asphalt, 42 tons @ invoice of \$32.00/ton	<u>1,344.00</u>
---	-----------------

Total Material \$1,344.00

Fringe Benefits:

Operator 10 hrs @ 3.20	\$32.00
Labor 20 hrs @ 2.59	51.80
Truck driver 6 hrs @ 2.64	<u>15.84</u>

Total Fringe Benefits 99.64

Summary (Total this billing)

Labor	\$479.62
+67% Labor	321.35
Equipment	1,028.00
Material	1,344.00
+15%Material	201.60
Fringe Benefits	99.64
+67% Fringe Benefits	<u>66.76</u>

TOTAL BILLING \$3,540.97

Form 46 - Concrete Truck Mixer Inspection Certification

Completion Instructions

Form 46 is used to document inspection and certification of the concrete supplier's truck mixers for compliance with subsection 601.07(c) of the *Standard Specifications*. Form 46 should be completed by the concrete supplier and returned to the Project Engineer prior to delivery of concrete to the project site. Each mixer hauling to the project site is required to be inspected. Complete Form 46 as follows:

1. Project No., Date, Project Code (SA#), Project Location, and Concrete Company. *Enter the project number, date, project code, project location, and concrete supplier's name in the appropriate cells of Form 46.*
2. Unit Number. *Enter the unit number of each mixer truck delivering to the project.*
3. Inspection Requirements. *Each unit hauling to the project must be inspected for the requirements listed on Form 46.*
4. Inspected By. *The employee of the concrete supply company that performed the inspection must initial Form 46 in these cells.*
5. Concrete Company Principal Executive Signature. The principle executive of the concrete supply company signs this cell to certify the inspection of the listed concrete truck mixers.
6. Batch Plant. *The Project Inspector enters the batch plant certifier's name, date of certification, and date of meter certification and then signs the form.*

Appendix B

COLORADO DEPARTMENT OF TRANSPORTATION CONCRETE TRUCK MIXER INSPECTION CERTIFICATION	Project code (SA#)	Date
	Project No. ①	
	Proj. location	
	Concrete company	

Unit number	②						
Rated mixing capacity (1)	}	③					
Blade wear (2)							
Free of Hardened concrete (3)							
Revolution counter							
Water gauges							
Meets operating speed requirements							
Date inspected							
INSPECTED BY (company employee)	④						

(1) Rated mixing capacity cannot exceed 63% of gross volume of drum

(2) Blade wear cannot exceed more than 25 mm (one inch) of the original height. For typical blade configurations see "x" dimensions below.

Mixer blade types:

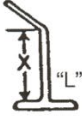

"L"



"Straight"

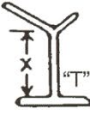

"T"

(3) The drum cannot have an appreciable accumulation of hardened concrete inside.

I certify the truck mixers listed above were inspected and met the requirements for conformance with the AASHTO M157 specifications.

I DECLARE UNDER PENALTY OF PERJURY IN THE SECOND DEGREE, AND ANY OTHER APPLICABLE STATE OR FEDERAL LAWS, THAT THE STATEMENTS MADE ON THIS DOCUMENT ARE TRUE AND COMPLETE TO THE BEST OF MY KNOWLEDGE.

Concrete company's principal executive, signature and title

⑤

Completed and checked by CDOT personnel	
Batch plant scale certification (Certifiers name and date)	Batch plant water meter certification date
Signed ⑥	Title
Remarks:	

Distribution: original - Region laboratory CDOT Form #46 3/04
 1st copy - Resident/Project Engineer
 2nd copy - Concrete company

Form 103 - Project Diary

Completion Instructions

Form 103 may be used to log the project diary. A project diary contains general information that the Project Engineer deems to be relevant to the project. Complete Form 103 as follows:

1. Project No. and Date. *Fill in as appropriate.*
2. Time, Employee, and Weather Information. *Enter the total days charged to date, elapsed days, hours worked, approximate number of employees, supervisory personnel, time lost and reason, weather condition, and temperature range.*
3. Diary Entry. The following are suggested topics that the diary entry should address:
 - a. changes in weather conditions during working hours;
 - b. type of work performed;
 - c. location where work was performed;
 - d. materials delivered to the project;
 - e. equipment deliveries, breakdowns, and equipment stored on the project;
 - f. access to site or work area;
 - g. traffic incidents, detour shifts, etc.;
 - h. visitors to the project site;
 - i. conversations with and directives to the Contractor;
 - j. potential or developing problems; and
 - k. any other topic deemed important by the Project Engineer.
4. Additional space is provided on the second page of Form 103.
5. Signing and Barricading and Traveled Roadway Condition. *Fill in as appropriate.*
6. Signature and Title. *Form 103 is signed and dated in these cells.*

Appendix B

COLORADO DEPARTMENT OF TRANSPORTATION PROJECT DIARY		Project No.:	①
		Sample	
Date:		7/XX/20XX	
Total Days Charged to Date:	Elapsed Days:	Hours Worked:	
37	48	10	
Approximate Number of Employees:	Weather:	Temperature Range:	
14	Partly Cloudy	70° - 84° F	
Time Lost and Reason:	Supt.:		
②			

Began clearing and grubbing removal at Station 125+50 right to 127+40 right. Three laborers with tandem and skid loader for clean up.

Traffic signal poles and mast arms delivered and stockpiled. Certificates of Compliance to be sent later. Minor paint touch up needed on two mast arms. Supt. will do.

Detector loops on northbound approach installed as per plan. All traffic control for this operation in accordance with approved Method of Handling Traffic "E." ABC, Inc. doing work as subcontractor.

Tech I Inspector and Temporary Ticket Taker on project. Tester at Region Laboratory for today.

PSCO contacted at 1:15 PM – will be on site tomorrow morning to connect power service link and install meter.

Traffic control subcontractor made night inspection. See Traffic Control Supervisor Diary for this date.

③

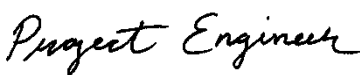
Signing and Barricading: Traffic Control Plan in place in accordance with Method of Handling Traffic "B2."		④
Traveled Roadway Condition: Class 6 detour for ramp to eastbound State Highway 2.		
Signed:		⑤
Title:		

Distribution: Project File (original)

CDOT Form 103 07/02

Form 105 - Speed Memo

Completion Instructions

Form 105 may be used for intradepartmental correspondence or to provide timely or immediate written communication between the Project Engineer and the Contractor. The following instructions apply when the form is used for communicating with the Contractor (i.e., construction distribution):

1. Project No., Project Code (SA#), and Location. *Enter the appropriate project number, project code, and location.*
2. Contractor Information and Date. *Enter the name of the Contractor's designated Superintendent, the Contractor's name, and the date.*
3. Subject and Message. Form 105 may be used for any of the following purposes:
 - a. issue direction to the Contractor;
 - b. accept, approve, or reject submittals;
 - c. document an agreed unit price, method of measurement, or basis of payment for extra work;
 - d. accept or reject specific work items;
 - e. delete bid items;
 - f. document verbal agreements; and
 - g. document Region preapproval for change orders.

See Section 120 of this Manual to determine when a change order is required.

4. CDOT Personnel Signature and Title. *The Project Engineer, or assigned designee, should sign Form 105 at this location.*
5. Contractor Personnel Signature and Title. *The Contractor's Superintendent should sign and date the Form 105 to document receipt. If the Contractor's Superintendent refuses to sign the Form 105, the Project Engineer should write the following information on the bottom half of the form and give the Superintendent a copy:*
 - a. "Contractor's Superintendent refused to sign," and
 - b. date and time.
6. Reply. *The lower half of Form 105 allows for a reply by the Contractor's Superintendent.*

Appendix B

7. Contractor Personnel Signature and Title. *The Contractor's Superintendent or other individual replying to the memo should sign and date the Form 105.*
8. Distribution. *When communicating with the Contractor, retain the original Form 105 with the Contractor's signature in the project file.*

Appendix B

COLORADO DEPARTMENT OF TRANSPORTATION SPEED MEMO	Project No.: 1	Project Code (SA#):
	Location:	
MESSAGE		Date: / /
To:	2	
Subject:	3	
	3	
	3	
Signed (CDOT): 4	Title: 4	
By Signing Below I Acknowledge Receipt of This Document		
Signed (Contractor): 5	Title: 5	
REPLY		Date: / /
To:	6	
	6	
Signed: 7	Title: 7	

Distribution:
Contractor
Resident Engineer
Project Engineer

8



CDOT Form 105 05/10

Form 200 - OJT Training Questionnaire

Completion Instructions

Form 200 is used to monitor the Contractor's compliance with the Training Special Provision by interviewing the trainee. It is normally completed by project personnel or by the Region Civil Rights Office. Upon completion, it is forwarded to the Civil Rights and Business Resource Center and placed in the labor interview file.

Appendix B

COLORADO DEPARTMENT OF TRANSPORTATION OJT TRAINING QUESTIONNAIRE		Project No.: IR 70-1 (30)	Project Code (SA#): 11111
		Project Location: Idaho Springs	Date: 5/11/80
Contractor's Name: XYZ Construction			
Trainee's Name: Jose Gonzales		Worker Classification: Carpenter	
Trainee's Address: 2355 1 st Ave., Denver CO 80122		Telephone No.: 426-0009	
Trainee's Social Security No.: 527-82-0052	<input checked="" type="checkbox"/> Male <input type="checkbox"/> Female	<input type="checkbox"/> Black <input checked="" type="checkbox"/> Hispanic	<input type="checkbox"/> Am. Indian <input type="checkbox"/> Asian Am. <input type="checkbox"/> Other
Have you ever received any apprenticeship training under any type of program before beginning this program? <input type="checkbox"/> Yes <input checked="" type="checkbox"/> No If yes, where?			
When did you enter the current program? Month: May Year: 1980			
In what type of training program are you enrolled? <input type="checkbox"/> Colorado Contractor's Association <input checked="" type="checkbox"/> Contractors OJT Program <input type="checkbox"/> Union Apprenticeship Program <input type="checkbox"/> Other:			
How did you learn about the program? <input type="checkbox"/> Contractor <input checked="" type="checkbox"/> Community Based Organization <input type="checkbox"/> Union <input type="checkbox"/> Other:			
When you entered your training, did anyone explain the program to you? <input checked="" type="checkbox"/> Yes <input type="checkbox"/> No If yes, explain: Reviewed program with Supervisor.			
Did you receive a copy of your training program? <input checked="" type="checkbox"/> Yes <input type="checkbox"/> No			
Which of the following aspects of the training program were explained to you? <input checked="" type="checkbox"/> Training Hours <input type="checkbox"/> Type of Training <input checked="" type="checkbox"/> Training Wages <input type="checkbox"/> Job Choices <input type="checkbox"/> Entry Wages			
Did you understand the training program discussed with you? <input checked="" type="checkbox"/> Yes <input type="checkbox"/> No If no, explain:			
What is your current stage of training? <input type="checkbox"/> 25% <input type="checkbox"/> 80% <input checked="" type="checkbox"/> 60% <input type="checkbox"/> 90%			
How many hours of training do you receive each week? On-Job-Site Training: 40 hours/week Classroom Training: 0 hours/week			
Are you keeping a record of your training hours? <input type="checkbox"/> Yes <input checked="" type="checkbox"/> No			
Do you believe proper training is being given? <input checked="" type="checkbox"/> Yes <input type="checkbox"/> No If no, explain:			
Does the job superintendent, trainer, or foreman show interest in helping you reach your goal of journeyman? <input checked="" type="checkbox"/> Yes <input type="checkbox"/> No			
Do you have any problems that may interfere with your training? <input type="checkbox"/> Yes <input checked="" type="checkbox"/> No If yes, explain:			
Have you ever received any type of counseling from the apprenticeship counselor or another? <input type="checkbox"/> Yes <input checked="" type="checkbox"/> No If yes, explain:			
Do you know the name of your trainer? <input checked="" type="checkbox"/> Yes <input type="checkbox"/> No If yes, what is the name of your trainer? Mike Barrett			
Interviewer's Signature: 		Date: 5/11/80	
Trainee's Signature: 		Date: 5/11/80	

Distribution: CDOT Business Programs Office (original)

CDOT Form 200 07/02

Form 262 - Weekly Time Count Report - Work Days

Completion Instructions

Form 262 is used to record project time charges when the Contract specifies a working day basis. Time charges should be made in accordance with the *Project Special Provisions* or subsection 108.08 of the *Standard Specifications*. A Form 103 - Project Diary should substantiate the daily assessment of Contract time. An automated version of Form 262 is available in SiteManager®. See Section 120 of this *Manual* for additional information on Contract time and Form 262. One Form 262 will be completed by the Project Engineer and should be signed by the Contractor weekly as follows:

1. Project #. *Fill in as appropriate.*
2. Project Code (SA#). *Fill in as appropriate.*
3. No. *Enter the sequential number. Begin with number one and continue numbering sequentially throughout the project.*
4. To. *Enter the Contractor name.*
5. Date. *Enter the date the form was generated.*
6. Week Ending. *Enter the month and date of the last day of the week the Form 262 represents.*
7. Date. *Enter the date for each weekday.*
8. Day. *Enter the Day of the week.*
9. Weather, weather conditions or other causes. *Describe the weather conditions for each day of the week. Also document any cause that explains why you charged or did not charge time. This is important to document if a dispute about time occurs.*
10. Workable days. *Mark each day the Contractor could prosecute work.*
11. Unworkable Days (weather). *Mark each day that adverse weather conditions prevented the Contractor from performing work.*
12. Days not chargeable other causes. *Mark each day that is not chargeable or the Contractor did not work due to other causes such as weekends, holidays, free time, or time suspension.*

Appendix B

13. Days charged this week. *Enter totals for the week.*
14. Days previously reported. *Enter the total days charged to date from the previous week's Form 262.*
15. Total days charged to date. *Enter the sum of Days charged this week (13.) and Days previously reported (14.).*
16. Work days allowed by original contract. *Enter the work days allowed by the original Contract.*
17. Extra days approved by Change Orders. *Enter the additional days added by change orders. Enter as participating if added days have been approved for Federal participation, otherwise enter as nonparticipating.*
18. Total revised contract days. *Enter the sum of Work days allowed by original contract (16.) and Extra days added by Change Orders (17.).*
19. Total days charged to date. *Enter the sum of all workable days charged to date.*
20. Total days remaining. *Enter the difference between Total revised contract days (18.) and Total days charged to date (19.).*
21. Elapsed Time. *Enter the sum of all days, workable and unworkable, and not chargeable to other causes, since the start of Contract time. This should be equal to calendar days.*
22. Remarks. *Note any unusual conditions or problems, and provide further explanation of any time charges or non-charges, suspensions, etc.*
23. Project Engineer. *Project Engineer signs here.*
24. Contractor's Comments. *The Contractor can enter comments here. The Contractor is to acknowledge receipt by signing and dating the completed Form 262. The Contractor should indicate if the company intends to submit a written request for an extension of time or correction of the time count. The Contractor has 30 days to file the written protest. See subsection 108.08 of the Standard Specifications. If the Contractor refuses to sign the completed Form 262, the original copy should be sent immediately by registered mail to the Contractor's permanent address.*

Appendix B

COLORADO DEPARTMENT OF TRANSPORTATION WEEKLY TIME COUNT REPORT- WORK DAYS	Project # 1 NH0062-030	Project Code (SA#) 19323 2	No. 3 17
	To 4 MARTIN MARIETTA MATERIALS	Contractor	Date 5 12/17/13

The following statement shows the number of work days charged to your contract for the week ending November 9, 2013 **6**

Date 7	Day 8	Weather, weather conditions or other causes 9	Workable days 10	Unworkable days (weather) 11	Days not chargeable other causes 12
11/03/13	sun	High - 67 Low - 37 Cldy. Lt. Rain 9	0.0 10	1.0 11	0.0 12
11/04/13	mon	High - 43 Low - 23 Cldy. Lt. Rain/Snow Mix	0.0	1.0	0.0
11/05/13	tue	High - 43 Low - 30 Ptly. Cldy.	1.0	0.0	0.0
11/06/13	wed	High - 53 Low - 19 Clear	1.0	0.0	0.0
11/07/13	thur	High - 61 Low - 22 Ptly. Cldy.	1.0	0.0	0.0
11/08/13	fri	High - 65 Low - 36 Clear	0.0	0.0	1.0
11/09/13	sat	High - 69 Low - 32 Clear	0.0	0.0	1.0

Days charged this week 13	3.0	2.0	2.0
Days previously reported 14	66.0	12.0	34.0
Total days charged to date 15	69.0	14.0	36.0
Work days allowed by original contract 16			75.0
Extra days approved by Change Orders- Participating 17			0.0
Nonparticipating			
Total revised contract days 18			75.0
Total days charged to date 19			69.0
Total days remaining 20			6.0
ELAPSED TIME 21			119.0

Remarks 22 11/8 - 9: No active traffic control allowed due to Veteran's Weekend events, therefore no work allowed.
Project Engineer 23

Contractor's comments 24	
Date	Contractor

Contractor
Region Program Engineer
Central Files

Resident Engineer
Project Engineer

CDOT Form #262a 06/00

Form 263 - Weekly Time Count Report - Calendar Days

Completion Instructions

Form 263 is used to record project time charges when the Contract specifies a calendar day basis. Calendar day, as defined in subsection 101.09 of the *Standard Specifications*, is defined as follows: “Each and every day shown on the calendar, beginning and ending at midnight.” All time charges should be made in accordance with the *Project Special Provisions* or subsection 108.08 of the *Standard Specifications*. Form 103 - Project Diary should substantiate the daily assessment of Contract time. An automated version of Form 263 is available in SiteManager®. See Section 120 of this *Manual* for additional information on Contract time count and Form 263. One Form 263 will be completed by the Project Engineer and should be signed by the Contractor weekly as follows:

1. Project #. *Fill in as appropriate.*
2. Project Code (SA#). *Fill in as appropriate.*
3. No. *Enter the sequential number. Begin with number one and continue numbering sequentially throughout the project.*
4. To. *Enter the name of the Contractor.*
5. Date. *Enter the date the Form 263 was generated.*
6. Week Ending. *Enter the month and date of the last day of the week the Form 263 represents.*
7. Date. *Enter the date for each weekday.*
8. Day. *Enter the Day of the week.*
9. Weather, weather conditions, or other causes. *Describe the weather conditions for each day of the week. Also document any cause that explains no time was charged. This is important to document if a dispute about time occurs.*
10. Calendar Days. *Mark each day that is classified as a calendar day.*
11. Worked/Not Worked. *Mark each day the Contractor worked with “W” and each day no work was performed with “NW.”*
12. Days not chargeable other causes. *Mark each day not charged.*

Appendix B

13. Days charged this week. *Enter totals for the week.*
14. Days previously reported. *Enter the total days charged to date from the previous week's Form 263.*
15. Total days charged to date. *Enter the sum of Days charged this week (13.) and Days previously reported (14.).*
16. Calendar days allowed by original contract. *Enter the calendar days allowed by the original Contract.*
17. Extra days approved by Change Orders. *Enter the additional days added by change orders. Enter as participating if added days have been approved for Federal participation, otherwise enter as nonparticipating.*
18. Total revised contract days. *Enter the sum of Work days allowed by original Contract (16.) and Extra days added by Change Orders (17.).*
19. Total days charged to date. *Enter the sum of all workable days charged to date.*
20. Total days remaining. *Enter the difference between Total revised Contract days (18.) and Total days charged to date (19.).*
21. Elapsed Time. *Enter the sum of all days, workable and unworkable, and not chargeable to other causes, since the start of Contract time. This should be equal to calendar days.*
22. Remarks. *Note any unusual conditions or problems, and provide further explanation of any time charges or non-charges, suspensions, etc.*
23. Project Engineer. *Project Engineer signs here.*
24. Contractor's Comments. *The Contractor can enter comments here. The Contractor is to acknowledge receipt by signing and dating the completed Form 263. The Contractor should indicate if the company intends to submit a written request for an extension of time or correction of the time count. The Contractor has 30 days to file the written protest. See subsection 108.08 of the Standard Specifications. If the Contractor refuses to sign the completed Form 263, the original copy should be sent immediately by registered mail to the Contractor's permanent address.*

Appendix B

COLORADO DEPARTMENT OF TRANSPORTATION WEEKLY TIME COUNT REPORT- CALENDAR DAYS	Project # ER 0241-059 1	Project Code (SA#) 19222 2	No. 3 3
	To HAYWARD BAKER, INC. 4	Contractor	Date 12/17/13 5

The following statement shows the number of calendar days charged to your contract for the week ending August 4, 2012 **6**

Date 7	Day 8	Weather, weather conditions or other causes 9	Calendar days 10	Worked (W) No Work (NW) by Contractor 11	Days not chargeable other causes 12
07/29/12	sun	High - 58 Low - 30 Cloudy, Light Rain in PM 9	1.0 10	NW 11	0.0 12
07/30/12	mon	High - 55 Low - 38 Cloudy Rain PM	1.0	NW	0.0
07/31/12	tue	High - 42 Low - 25 Cloudy Rain PM	1.0	NW	0.0
08/01/12	wed	High - 65 Low - 45 Sunny Dry	1.0	W	0.0
08/02/12	thur	High - 67 Low - 48 Mostly Clear Dry	1.0	W	0.0
08/03/12	fri	High - 65 Low - 45 Sunny Dry	1.0	W	0.0
08/04/12	sat	High - 67 Low - 48 Mostly Clear Dry	1.0	W	0.0

Days charged this week 13	7.0	0.0
Days previously reported 14	11.0	0.0
Total days charged to date 15	18.0	0.0
Calendar days allowed by original contract 16		20.0
Extra days approved by Change Orders- Participating 17		4.0
Nonparticipating		
Total revised contract days 18		24.0
Total days charged to date 19		18.0
Total days remaining 20		6.0
ELAPSED TIME 21		18.0

Remarks 22	
Project Engineer 23	

Contractor's comments 24	
Date	Contractor

Contractor
Region Program Engineer
Central Files

Resident Engineer
Project Engineer

CDOT Form #263a 06/00

Form 266 - Inspector's Progress Report

Completion Instructions

Form 266 is used for source documentation of interim and final quantities. Form 266 must contain the required data for the pay item being documented. For documentation requirements of individual Contract pay items and further information on Form 266, see Section 120 of this *Manual*. The following describes how to complete Form 266:

1. Project No., Project Code (SA#), Date, No. of Workers, and Equipment. *Enter the project number, project code, date (must not be later than date of project acceptance), number of workers, and the equipment utilized by the Contractor to complete the work.*
2. Location, Comments, and Supporting Calculations. *Information to be provided in this section of Form 266 includes location of the work, quantity calculations, and total quantity being paid on Form 266. The second page of Form 266 may be used for additional calculations and sketches, as appropriate, to support the pay quantity. Additional supporting documents may be attached to the form. The total pay quantity should be rounded to the appropriate significant figures as discussed in Section 121 of this Manual. All calculations should be checked and a mark placed next to each checked value.*
3. Interim/Final. *Check the appropriate box for interim measurement or final measurement for that pay quantity or portion of the item.*
4. Calculated By. *This cell of Form 266 should be signed or initialed by the person who performed the calculations.*
5. Measured By. *This cell of Form 266 should be signed or initialed by the person who performed the field measurements or counted the item.*
6. Posted By. *This cell of Form 266 should be signed or initialed by the person who transferred the total quantity from the Form 266 to the Item Summary Report.*
7. Checked By. *This cell of Form 266 should be signed or initialed by the individual who checked the calculations and quantities on the Form 266. This check must --be performed by an individual other than the person who determined the quantity. This check should be completed in accordance with Section 121 of this Manual.*

Appendix B

8. Reference and Item Number. *Enter the computer reference number and the item number for the pay item. Entering the computer reference number is optional as determined by the Region.*
9. Item Description. *Enter the description of the item. The description should match the description on the Summary of Approximate Quantities on the plans, if appropriate. The location may be entered if it is not shown in the location, comments, and supporting calculations section of Form 266.*
10. Quantity. *Enter the total quantity this Form 266 represents.*
11. Unit. *Enter the appropriate unit of measurement for the item.*
12. Signed and Title. *The signature and title cells are for the individual who is responsible for the inspection and documentation of the pay item. This is usually performed by the person completing the Form 266.*
13. No. *Enter the sequential number of the Form 266 in the series of source documents for the pay items. This is usually performed by the person who posted the quantity.*

**COLORADO DEPARTMENT OF TRANSPORTATION
INSPECTOR'S PROGRESS REPORT**

Project No.: C 00XX-00XX	Project Code (SA#): 11111	Date: 7/X/XX
No. of Workers: 3	Equipment: 1.5-ton Flatbed, Tractor with Loader, Handtools	

Location, Comments, and Supporting Calculations:
Contractor has completed removal of fence at the following locations:

Station 350+80 right to 372+25 right	2,145 linear feet
Station 372+41 right to 389+00 right	1,659 linear feet
Station 360+90 right to 390+72 right	2,982 linear feet
Total	6,786 linear feet

Contractor has retained materials per the Special Provisions and has removed them from the project.

<input type="checkbox"/> Interim	<input checked="" type="checkbox"/> Final	Calculated By: SM 7-X-XX	Measured By: SM 7-X-XX
		Posted By: HK 8-X-XX	Checked By: HK 8-X-XX

Reference and Item Number	Item Description	Quantity	Unit
0010-202	Removal of Fence	6,786	linear feet

The item(s) and material(s) listed above were inspected and found to conform reasonably with the Contract Plans and Specifications, except as noted.

Signed: <i>Sean Malley</i>	Title: CEPM I	No.: 202-10-3
----------------------------	---------------	---------------

Appendix B

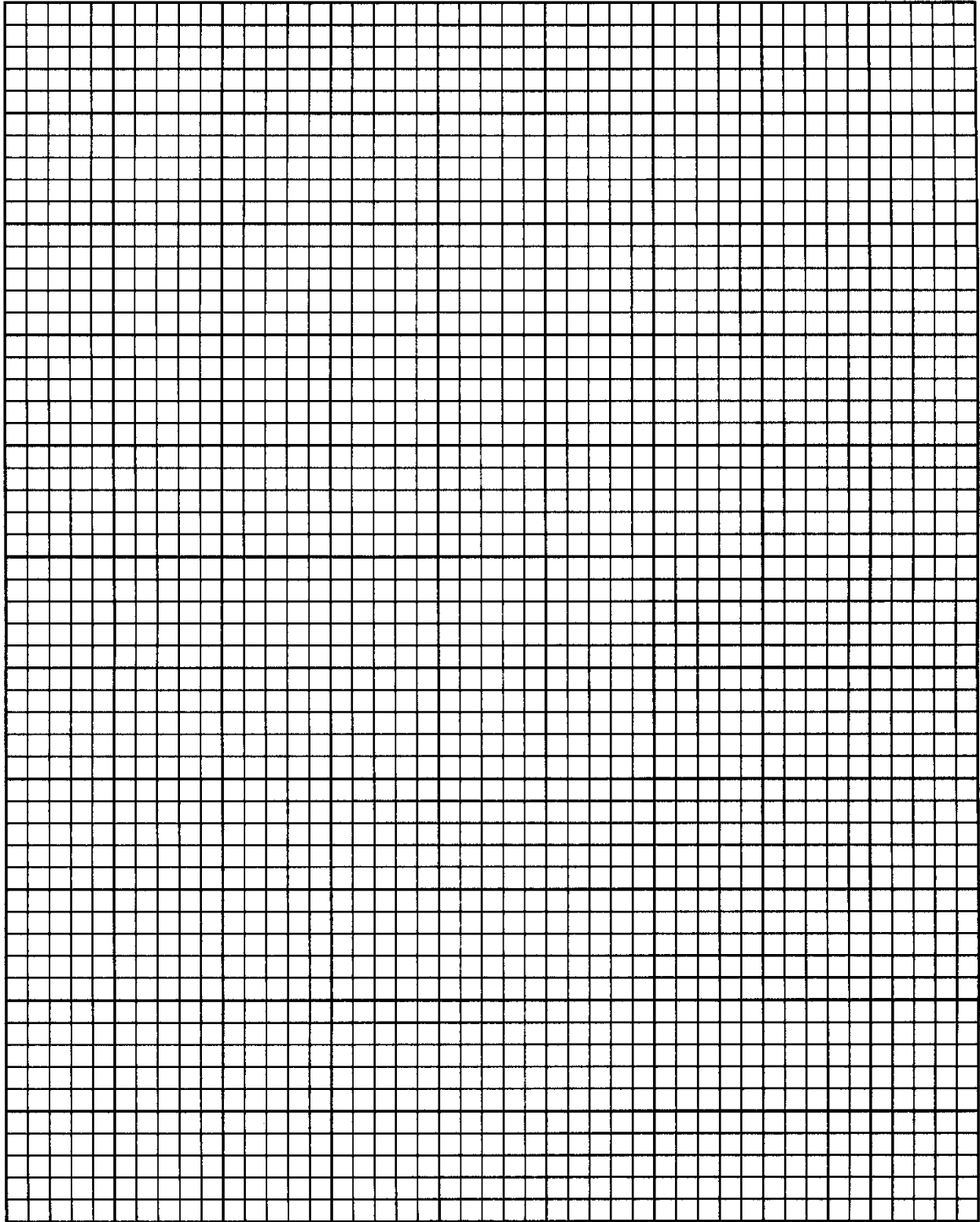

CDOT Form 266 07/02

Form 279 - Inspector's Report of Reinforcing Steel Placed

Completion Instructions

Form 279 is an optional form that may be used for source documentation of interim and final quantities of reinforcing steel or for revisions to plan quantities. See Section 121.2.1 of this *Manual* for additional information on requirements for Basis of Payment Documentation. The following describes how to complete Form 279:

1. Project No., Project Code (SA#), and Date. *Enter the project number, project code, and date. The date must not be later than date of project acceptance.*
2. Equipment and No. of Workers. *Enter the equipment utilized by the Contractor to complete the work and the number of workers.*
3. Station, Structure, and Portion. *Enter the station, left or right, structure number, and portion of structure, if applicable (e.g., deck, abutment, structure wall, approach slab).*
4. Mark, Bar No., and Length. *Enter the mark, bar number, and length. If the plans or supplier's bar list or bending diagram do not designate a mark (e.g., 401, 523), show the shape of the bar. Inspection should be made to ensure compliance with the plans.*
5. No. of Bars. *Enter the number of bars of this type placed for this Form 279.*
6. Total Length, Weight per Unit Length, Total Weight. *Enter the total length, weight per unit length, and total weight. Be sure to use the correct unit of measurement. Either multiply bar length times weight per foot for each bar or add the total length for each size and then multiply by the proper weight per foot.*
7. Space and Clear. *Enter the plan bar space and clearance. This information may be used to inspect the in-place rebar.*
8. Total. *Enter the total quantity this Form 279 represents.*
9. Remarks. *Any comments or information supporting the item may be made in this section. Additional supporting documents, calculations, or sketches may be attached to the Form 279.*
10. Interim/Final. *Check the appropriate box for an interim or a final measurement for the portion of the pay item represented by this Form 279.*

Appendix B

11. Calculated By, Measured By, Posted By, and Checked By. *These cells must be signed or initialed by the individual who performed the functions.*
12. Computer Reference No. *Enter the computer reference number for the item. This is an optional entry.*
13. No. *Enter the sequential number of the Form 279 in the series of source documents for the pay item. This is usually performed by the person posting the quantity.*

Appendix B

COLORADO DEPARTMENT OF TRANSPORTATION INSPECTOR'S REPORT OF REINFORCING STEEL PLACED								
Project No.: CX XX-0000 (1)			Project Code (SA#): 11111 (1)			Date: 7/XX/XX (1)		
Equipment: Flatbed with Crane, Cutting Torch, Handtools (2)					No. of Workers: 4 (2)			
Station: 291+40 right (3)		Structure: Noname CBC Ext. (3)		Portion: Floor, Apron and Toe (3)				
Mark	Size		No. of Bars	Total Length	Weight per Unit Length	Total Weight	Space	Clear
	Bar No.	Length						
401 ---	5	6'-8"	14	93.33	1.043	97.3	8"	3"
403 ---	5	6'-8"	8	53.33	55.6	55.6	8"	---
407 ---	6	6'-8"	8	53.33	80.1	80.1	1'-0"	3"
402 L	6	5'-3"	16	84.00	126.2	126.2	1'-0"	2"
404 L	4	5'-3"	16	84.00	56.1	56.1	8"	2"
	5	4'-6"	9	40.50	42.2	42.2	1'-6"	---
(4)		(5)		(6)		(7)		
						457.5		
(8) TOTAL						458		
Remarks: Portion paid checks with plan quantity. (9)					Metric		English	
					Bar No.	kg/m	Bar No.	lb/ft
<input checked="" type="checkbox"/> Interim (10) <input type="checkbox"/> Final Calculated By: SM 7-X-XX (11) Measured By: SM 7-X-XX (11) Posted By: HK 8-X-XX (11) Checked By: HK 8-X-XX (11)					10m	.785	3	.376
					15m	1.570	4	.668
The above bars were placed into the structure in a manner which is in accordance with C.R.S.I recommendations. THE ITEM(S) AND MATERIAL(S) LISTED ABOVE WERE INSPECTED AND FOUND TO CONFORM REASONABLY WITH THE CONTRACT PLANS AND SPECIFICATIONS EXCEPT AS NOTED.					20m	2.355	5	1.043
					25m	3.925	6	1.502
Signed:					30m	5.495	7	2.044
					35m	7.850	8	2.670
Title: ETI					45m	11.775	9	3.400
					55m	19.625	10	4.303
Computer Reference No.: 110-602 (12)					35m	7.850	11	5.313
					No.: 3 (13)	45m	11.775	14
Distribution: Project File (original)					55m	19.625	18	13.60

Form 280 - EEO and Labor Compliance Verification

Completion Instructions

Form 280 is used to interview employees of Contractors and subcontractors to verify that employees are aware of each company's Equal Employment Opportunity (EEO) requirements and that they are receiving the correct wages for the classification in which they are working. Form 280 should be completed by CDOT project site personnel as addressed in Section 107.1.3 of this *Manual* and when labor or EEO violations are suspected. The Region EEO/Civil Rights Specialists may also use this form during compliance reviews and investigations. Complete Form 280 as follows:

1. Project No., Project Code (SA#), Project Location, and Contractor Name. Fill in as appropriate. Note if the name is for a subcontractor.
2. Employee Name and Job Classification. Enter the name of the employee interviewed and the worker's job classification.
3. Equal Employment Opportunity. The Equal Employment Opportunity section of Form 280 includes the questions that should be asked of the employee regarding his knowledge of the equal employment policies and procedures of his employer.
4. Labor Compliance. The Labor Compliance section of Form 280 includes questions that should be asked of the employee regarding wage rate, fringe benefit plan, and pay frequency. It allows the interviewer to verify the type of work being performed by the employee. The employee is requested to look over the interview and sign and date the form.
5. Verification Section. The interviewer completes the verification section by referring to the appropriate payroll for information on the hourly rate and classification of the employee and verifying from the Contract wage decision that the employee is paid correctly. Errors in classification, hourly wage, or fringe benefit must be corrected and back wages calculated as necessary. The interviewer completes the form with the individual's signature and date.

Should interviews reveal a pattern or lack of knowledge by employees, the Region's EEO/Civil Rights Specialist should be notified immediately.

Employer requests to review interviews should be referred to the Contracts and Market Analysis Branch.

COLORADO DEPARTMENT OF TRANSPORTATION EQUAL EMPLOYMENT OPPORTUNITY AND LABOR COMPLIANCE VERIFICATION (COLORADO DEPARTAMENTO DE TRANSPORTACION OPORTUNIDAD Y EMPLEO IGUAL VERIFICACION DE CONFORMIDAD DE TRABAJO)		PROJECT # (Numero De Proyecto) ①
		LOCATION ①
		Project code (SA#) ①
Contractor's name (Nombre De Contratista) ①		
Employee's name (Nombre De Empleado) ②		Job classification (Clasificacion De Trabajo) ②

JOB SITE INTERVIEW SECTION (SECCION DE INVESTIGACION DE TRABAJO)

EQUAL EMPLOYMENT OPPORTUNITY (EEO) La Igualdad De Oportunidades de Empleo

- Have you seen the EEO posters posted by this contractor? (¿Ha visto los cartelones de EEO puestos por el contratista?)
 yes (si) no
- Do you know the EEO policy of your contractor? (¿Usted conoce la politica de EEO del contratista?) ③
 yes (si) no
- Do you know who the project EEO officer is? (¿Usted sabe, quien es el oficial de EEO del proyecto?) yes (si) no
 Who is he/she? (¿Si sabe, digame el nombre del oficial del EEO?) _____
- Have you ever been requested by the contractor or any of his/her staff to refer minorities and women when job openings are available? (¿Le han preguntado el contratista o empleados del contratista que envíe a gente de las poblaciones minoritarias o a mujeres, para que apliquen para oportunidades del empleo?) yes (si) no
- Has the contractor advised you of training or apprenticeship programs available to upgrade your skills? (¿Le ha ofrecido el contratista entranamiento o programas de aprendizaje para mejorar sus habilidades?) yes (si) no
- How long have you been employed by this contractor? (¿Cuanto tiempo ha estado empleado por este contratista?)
 _____ years (años) _____ months (meses) _____ days (días)
- How did you get this job? (¿Como consejio este trabajo?) union other (otro modo): _____
- Have you attended any meetings on this project where EEO was discussed? (¿Ha atendido una reunion en este proyecto cuando EEO fue discutido?) yes (¿Si si, cuando fue la reunion?), date (fecha) ____/____/____ no
- Do you feel the contractor has discriminated against you in any way? (¿Siente que el contratista ha discriminado contra usted en algun modo?) yes (si) no

LABOR COMPLIANCE (CUMPLIMIENTO DE TRABAJO)

- Have you seen the wage posters posted by the contractor? (¿Ha visto los cartelones de sueldo puesto por el contratista?)
 yes (si) no ④
- What is your wage rate? (¿Cuál es su sueldo por hora?) \$ _____ hr. (por hora)
- What is your fringe benefit amount? (¿Cuanto le dan por hora como pago por sus beneficios complementarios?)
 \$ _____ hr. (por hora)
 total wage (¿SUELDO completo POR HORA?) \$ _____ hr. (por hora)
- Are fringe benefits paid to you in cash or does the contractor save them in approved plans, funds or programs? (¿Como le pagan los beneficios?)
 cash (dinero) funds (otro modo, planes, fondos, programas) Have you experienced any problems? (¿Ha tenido problemas con el pago de su beneficios? Si ha tenido problemas, describa por favor como:)

- How often are you paid? (¿Cada cuando le pagan?) weekly (por semana) other (otro modo) _____
- Describe work you are performing today. (Describa su asignacion corriente en su trabajo) _____

Employee signature (Firma del Empleado) _____ Date (Fecha) _____

VERIFICATION SECTION (SECCION DE VERIFICACION) (use the contractors payroll to answer the questions in this section)

- Are the employee's wages correct? yes no
- What is the total hourly amount? \$ _____ hr. ⑤
- What is the employee's worker classification? _____
- What is the payroll date? ____/____/____

COMMENTS

Interviewer signature _____ Date _____

Form 282 - Asphalt Paving Inspector's Daily Report

Completion Instructions

Form 282 may be used to document daily asphalt paving operations. Its use is optional in lieu of other acceptable recording methods, as determined by the Project Engineer, to record loads delivered, location placed, spread yield, and asphalt temperatures. Complete Form 282 as follows:

1. Weather, Air Temperature, and Date. Enter the date and enter the weather conditions and maximum and minimum air temperatures for that date.
2. Project No. and Project Code (SA#). Fill in as appropriate.
3. Load No. Record the load number from the Contractor's load ticket. The load number will indicate the sequential loading order from the plant. If a load arrives to the project site out of sequence according to the load number, the truck may have been substantially delayed and the Hot Bituminous Pavement temperature should be checked against allowable minimum temperature, as per specification.
4. Ticket No. Enter the ticket number from the Contractor's load ticket for each load delivered to the project.
5. Ticket Weight. Enter the net weight (tons) from the load ticket of each load.
6. Cumulative Weight. Enter the cumulative weight of asphalt by adding the net weight for each ticket to the previous cumulative total.
7. Station to Station. Record the beginning and ending station of the placement location for each load of asphalt.
8. Location. Enter the lane and direction being paved.
9. Paver Pass. Record the thickness (inches) and width (feet) of asphalt being placed.
10. Course. Check the appropriate box for bottom or top lift.
11. Spread Yield. Any method to calculate spread yield is acceptable as long as the calculation results in an accurate comparison between the actual application rate and the plan application rate.

Appendix B

The following method provides a relative comparison of actual-to-plan application rates. A calculated result over 1.00 indicates that the actual application rate is exceeding the plan application rate. For example, a spread yield rate of 1.05 indicates that the plan quality is being overrun by five percent for the asphalt quantity placed.

First determine the correct plan application rate factor as follows:

$$\frac{2,000 \times 9}{\text{Plan Application Rate (pounds/square yard/inch)}}$$

The plan application rate can be found in the General Notes of the plans. In this example, use 112 pounds/square yard/inch.

$$\text{Factor} = \frac{2,000 \times 9}{112} = 160.7$$

Calculations can be completed for a single load, any portion of the day, or the entire day's run as follows:

$$\text{Factor} \times \text{Actual Tons/Thickness/Width/Station - Station Length}$$

Single Load: $160.7 \times 12.88/2/12.5/75 = 1.10$

Partial Day: $160.7 \times (109.04 - 26.83)/2/12.5/(52,680 - 52,160) = 1.02$

Entire Day: $160.7 \times 146.1/2/12.5/(52,915 - 52,000) = 1.03$

12. Mix Temp. Record the delivered mix temperature.
13. Remarks. Provide any appropriate remarks.
14. Signed and Title. The Form 282 needs to be signed by the person who completed the form.

CDOT DEPARTMENT OF TRANSPORTATION ASPHALT PAVING INSPECTOR DAILY REPORT

Weather: Clear, Warm		Date: 9/7/95		Project Code (SA#): 11111		②	
Air Temperature: Maximum: 80°		Minimum: 72°		Project No.: 11111		②	
Load No.		Ticket No.		Ticket Weight		Cumulative Weight	
Station to Station		Paver Pass		Course		Mix Temp.	
Thk.		Width		Bot.		Top	
Location		Spread Yield		Remarks			

Load No.	Ticket No.	Ticket Weight	Cumulative Weight	Station to Station	Location	Paver Pass Thk.	Paver Pass Width	Course Bot.	Course Top	Spread Yield	Mix Temp.	Remarks
1	8680	12.88	12.88	520+00 - 520+75	SB Lane	2"	12.5		✓	A 1.10	255°	North Approach
2	8681	13.95	26.83	520+75 - 521+60	SB Lane	2"	12.5		✓		260°	To Str. F-15-OP
3	8683	14.14	40.97	521+60 - 522+65	SB Lane	2"	12.5		✓		265°	
4	8685	23.02	63.99	522+65 - 524+00	SB Lane	2"	12.5		✓	B 1.02	260°	
5	8686	22.92	86.91	524+00 - 525+45	SB Lane	2"	12.5		✓			
6	8682	22.13	109.04	525+45 - 526+80	SB Lane	2"	12.5		✓		250°	
7	8687	14.00	123.37	526+80 - 527+70	SB Lane	2"	12.5		✓			
8	8688	22.73	146.10	527+70 - 529+15	SB Lane	2"	12.5		✓	C 1.03	260°	<--- Overhaul Yield (SB)
③	④	⑤	⑥	⑦	⑧	⑨	⑩	⑩	⑩	⑪	⑫	⑬

Signed: *J. Smith* (14)
 Title: EPST II

This item and the materials used were inspected and found to conform reasonably with the Contract Plans and Specifications as noted.

Distribution: Project File (original) CDOT Form 282 07/02

Form 568 - CDOT Temporary Speed Limit Reduction

Completion Instructions

A Form 568 must be completed, approved, and signed whenever the speed limit is reduced on a construction project, even if the speed limit reduction is shown on the plans.

The Project Engineer is responsible for initiating and completing the Form 568 when a reduced speed limit is appropriate.

Fill in the appropriate project information such as city, reduced speed limit, regular speed limit, and direction of traffic.

The Chief Engineer shall delegate signature authority to the Region Traffic Engineers or designee to determine appropriate temporary speed limits.

See instructions on the Form 568.



CDOT TEMPORARY SPEED LIMIT REDUCTION FORM 568

Required Information

* Indicates a required field.

CDOT Project Engineer or Manager

<input type="text" value="John"/> <i>First Name*</i>	<input type="text" value="Smith"/> <i>Last Name*</i>	<input type="text" value="Project Engineer"/> <i>Title*</i>
<input type="text" value="Region 4"/> <i>Region*</i>	<input type="text"/> <i>Section</i>	<input type="text"/> <i>Patrol</i>

Local Agency Representative, Contractor, or Consultant (if applicable)

<input type="text"/> <i>First Name</i>	<input type="text"/> <i>Last Name</i>	<input type="text"/> <i>Title</i>
<input type="text"/> <i>Agency or Company Name</i>	<input type="text"/> <i>Email</i>	<input type="text"/> <i>Phone Number</i>

Project Information

Subaccount No., Permit, or MPA Code*

Description of Project (example: bridge repair).*

Major Widening with reduced lane width of 11' and 2' shoulders.

Authority

The Department is legally authorized to temporarily reduce speed limits based on Colorado Revised Statute § 42-4-1102(1). The reduction must be based on an assessment of how the construction or maintenance work activity will impact traffic flow through the work zone. The traffic assessment, traffic investigation, or maintenance work order must be documented in this form. Additionally, CDOT projects which include recommendations for reduced speeds as part of the TSM&O evaluation shall include a copy of the evaluation report with this form. Procedural Directive 1502.2 "Temporary Reduction in Speed Limits" must be reviewed prior to execution.

Speed reductions shall only apply while the conditions exist that warrant the reduction. This is not always for the entire length and duration of the project. The permanently posted speed limits shall be effective upon completion of the speed reduction and signs shall be either unmasked or re-installed.

Note: If no work is occurring, temporary traffic control speed limit signs must be removed or masked within one hour of the completion of work.

The Chief Engineer shall delegate signature authority to the Region Traffic Engineers or designee, the LTC Ops I or higher (Maintenance Superintendents, Deputy Superintendents) to determine appropriate temporary speed limits. This Form 568 shall be routed to the Region Traffic Engineer for speed limit reductions associated with the issuance of a permit, an engineering project or a local agency project on a state highway, or a reduction of speed limit outside of Table I.

TABLE I
RECOMMENDED MINIMUM WORK ZONE SPEED LIMITS

Existing Posted Speed Limit	Minimum width Available to Traffic ¹	Non-active Work Zone Speed Limit ²	Active Work Zone Speed Limit ³	Approaching a Potential Full Stop Condition
75 MPH	14 FT	65 MPH	65-40 MPH	40 MPH
70 MPH	14 FT	60 MPH	60-40 MPH	40 MPH
65 MPH	14 FT	55 MPH	55-40 MPH	40 MPH
60 MPH	14 FT	50 MPH	50-40 MPH	40 MPH
55 MPH	14 FT	45 MPH	45-40 MPH	40 MPH
50 MPH	12 FT	40 MPH	40 MPH	40 MPH
45 MPH	12 FT	40 MPH	40 MPH	40 MPH

¹ Travel lane width adjacent to the shoulder plus the shoulder width. Reduced speeds are not recommended where width available to traffic exceeds these measurements.

² See notes 1 and 7 in Section (IV)(B) in PD 1502.2. Must include additional rationale for speed limit reduction for a non-active work zone.

³ See notes 1 and 7 in Section (IV)(B) in PD 1502.2. Speed limit should be set at the maximum value practical within this range and must be justified by the extent of exposure/risk.

Reduced Speed Limits Per Date/Time (This form is to be used per project.)

Reduction Request 1

000	12.5	13.9	EB
<i>State Highway*</i>	<i>From Mile Point*</i>	<i>To Mile Point*</i>	<i>Direction of Traffic*</i>
65	50	11/01/2019	2/25/2020
<i>Posted Speed Limit*</i>	<i>Temporary Reduced Speed Limit*</i>	<i>From Date & Time*</i>	<i>To Date & Time*</i>

Please provide justification for speed reduction (You must include a reason for reducing the speed limit any time a speed reduction is requested. Examples include: reduced clear zones, temporary alignment or geometric changes, exposure to workers, reduced sight distances, physical hazards, etc.)*

Reduced clear zone and sight distance.

Reduction Request 2

<i>State Highway</i>	<i>From Mile Point</i>	<i>To Mile Point</i>	<i>Direction of Traffic</i>
<i>Posted Speed Limit</i>	<i>Temporary Reduced Speed Limit</i>	<i>From Date & Time</i>	<i>To Date & Time</i>

Please provide justification for speed reduction (You must include a reason for reducing the speed limit any time a speed reduction is requested. Examples include: reduced clear zones, temporary alignment or geometric changes, exposure to workers, reduced sight distances, physical hazards, etc.)

Reduction Request 3

<i>State Highway</i>	<i>From Mile Point</i>	<i>To Mile Point</i>	<i>Direction of Traffic</i>
<i>Posted Speed Limit</i>	<i>Temporary Reduced Speed Limit</i>	<i>From Date & Time</i>	<i>To Date & Time</i>

Please provide justification for speed reduction (You must include a reason for reducing the speed limit any time a speed reduction is requested. Examples include: reduced clear zones, temporary alignment or geometric changes, exposure to workers, reduced sight distances, physical hazards, etc.)

Reduction Request 4

<i>State Highway</i>	<i>From Mile Point</i>	<i>To Mile Point</i>	<i>Direction of Traffic</i>
<i>Posted Speed Limit</i>	<i>Temporary Reduced Speed Limit</i>	<i>From Date & Time</i>	<i>To Date & Time</i>

Please provide justification for speed reduction (You must include a reason for reducing the speed limit any time a speed reduction is requested. Examples include: reduced clear zones, temporary alignment or geometric changes, exposure to workers, reduced sight distances, physical hazards, etc.)

Review and Approval

The signing authority is responsible for routing the approved form to the appropriate personnel per PD 1502.2.

I hereby Approve this request Deny this request.

Reason for denial:

Signal

*First Name**

Ahead

*Last Name**

Region Traffic Engineer

*Title**

Signal Ahead

Digitally signed by Signal Ahead
Date: 2019.10.23 08:48:23
-06'00'

*Signature**

October 23, 2019

*Date**

Form 580 - Equipment Rental Rate Determination Request

Completion Instructions

Form 580 is used when an hourly rate for Contractor owned equipment is required for payment under force account or for performing a force account analysis of a Contractor's proposed unit price for extra work for a change order price justification. Equipment rental rates and standby rates are calculated on the Form 580 using the current *Rental Rate Blue Book for Construction Equipment*. The Project Engineer completes the top half of the form and, generally, the Region Finals Engineer completes the bottom portion. The information is used for force account billings. Form 580 should be prepared as follows:

1. Project No. and Project Code (SA#). *Fill in the project number and project code as appropriate.*
2. Contractor and F/A, CMO, MCR No. *Enter the Contractor's name and the force account, contract modification order, or minor Contract revision number.*
3. Type/Description and Make. *Describe the equipment as completely and accurately as possible. (e.g., there is a difference between a backhoe and a hydraulic excavator). Also enter the equipment make.*
4. Year and Serial No. *The year of manufacture is important. If this information is not available, the serial number should be recorded because this can aid in determining the age of the equipment.*
5. Model and Series. *Enter the model number and series. Often the model number and series are contained in the same number (e.g., Model 570B). For this piece of equipment, the model number is 570 and the series is B.*
6. Fuel Type and Transmission. *Indicate the type of fuel the equipment uses and the transmission type.*
7. Trucks: Wheel Combination. *For all pickups, semis, dump trucks, etc., indicate the type of wheel power used. Wheel power is defined as the number of wheels times the number of wheels powered. Dual wheels are counted as single wheels.*
8. Gross Vehicle Weight (GVW) and Capacity. *For dump trucks, belly dumps, pups, water, and other liquid-haul trucks, enter the correct gross vehicle weight and capacity.*

Appendix B

9. Equipment Owner Name and Equipment Owner ID. *Enter the equipment owner's name and equipment owner ID, if available.*
10. Remarks. *Enter any needed remarks that describe the equipment.*
11. Submitted By, Region No., and Date. *Sign the Form 580 and enter the Region number and date.*
12. Equipment No. *The Region will assign an equipment number to be used to identify the specific piece of equipment and its hourly rates.*
13. Blue Book Reference. *Enter the volume, section, page, and date from the current Rental Rate Blue Book for Construction Equipment.*
14. Bare Rate. *See subsection 109.04(c) of the Standard Specifications for information on calculating the bare rate and the adjusted bare rate.*
15. Operating Cost. *The hourly operating cost is taken directly from the appropriate column in the Rental Rate Blue Book for Construction Equipment for the specific piece of equipment.*
16. Total Shift Rate Per Hour. *Enter the sum of the bare rate (#14) and the operating cost (#15).*
17. Adjusted Bare Rate. *The adjusted bare rate per hour for standby is calculated as 50 percent of the shift bare rate per hour calculated in #14 above.*
18. Standby Rate Per Hour. *The standby rate per hour is the adjusted bare rate as determined in #17 above.*
19. Signed, Title, and Date. *The person who calculated the rates signs and dates the Form 580.*

Appendix B

Examples of some common usages are shown below:

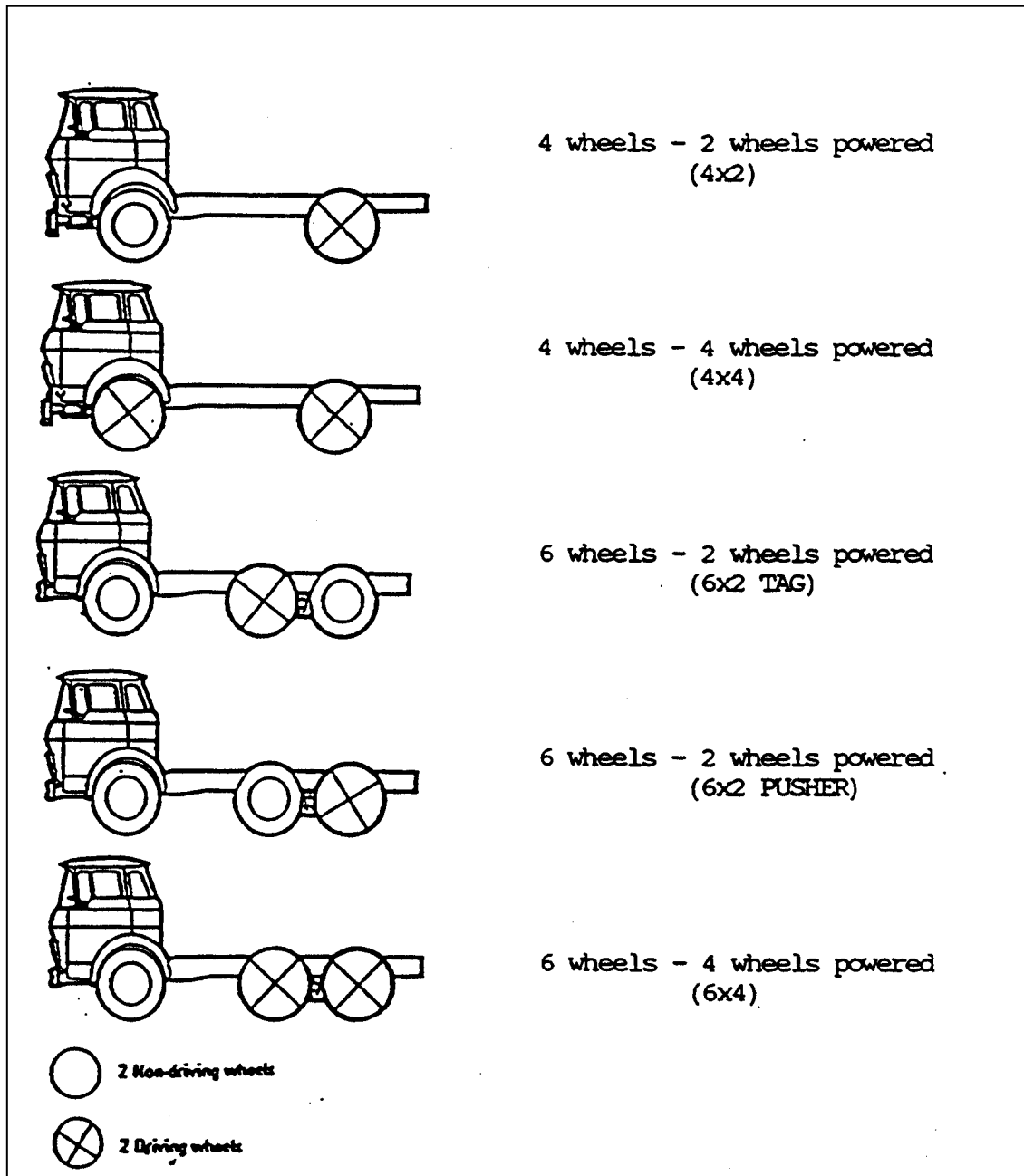

COLORADO DEPARTMENT OF TRANSPORTATION EQUIPMENT RENTAL RATE DETERMINATION REQUEST		Project No: Sample (1)	Project Code (SA#): 11111 (1)
		Contractor: Smith Construction Company (2)	
		F/A, CMO, MCR No.: CMO #9 (2)	
Type/Description: Motor Grader (3)		Make: Deere (3)	
Year: 1988 (4)	Model: 570 (5)	Series: B (5)	Serial No.: 515543 (4)
Fuel Type: <input type="checkbox"/> Gas <input checked="" type="checkbox"/> Diesel <input type="checkbox"/> Other: (6)		Transmission: <input type="checkbox"/> Direct Drive <input checked="" type="checkbox"/> Power Shift <input type="checkbox"/> Other: (6)	
Trucks: Wheel Combination: <input type="checkbox"/> 4x2 <input type="checkbox"/> 4x4 <input type="checkbox"/> 4x6 <input type="checkbox"/> Other: (7)		GVW (Loaded Weight): (8)	Capacity (cubic yards, gallons): (8)
Equipment Owner Name: Jones Excavating, Inc. (9)		Owner Equipment ID (if available): JE 13 (9)	
Remarks: Articulated Frame Grader (10)			
Submitted By: (11) <i>Jan Henderson</i>		Region No.: 1 (11)	Date: 3/15/94 (11)

RATE DETERMINATION

Equipment No. (Assigned by CDOT and may be used on CDOT Form 10 – Inspector's Report for Force Account Work): 94 - 3622 (12)			
BLUE BOOK REFERENCE:	Volume: 1 (13)	Section: 9 (13)	Date (Blue Book Section): 4/93 (13)
SHIFT RATE PER HOUR			
Bare Rate (Federal Participating):		(14)	\$35.60
Operating Cost (Federal Participating):		(15)	\$10.25
TOTAL		(16)	\$45.85
STANDBY RATE PER HOUR			
Adjusted Bare Rate (Federal Participating):		(17)	\$17.80
TOTAL		(18)	\$17.80

This rate will apply to the above entire F/A, CMO, or MCR Line situation. If used on any other force account situation, a new rate will be needed to determine if rate has changed per Blue Book Revisions.

The Colorado Department of Transportation maintains procedures for determining equipment rental costs which are reimbursable to contractors performing force account work on CDOT construction projects. These rates do not include profit or operator's wages or fringe benefits. These rates have no legal status beyond CDOT contracts.

Signed: (19) <i>Joe Walsh</i>	Title: ET I (19)	Date: 3/18/94 (19)
----------------------------------	---------------------	-----------------------

Form 832 - Trainee Status and Evaluation

Completion Instructions

Form 832 is used to monitor the project progress and status of both standard and pilot program trainees. Every month the Contractor shall complete and submit to the Project Engineer a Form 832 for every active trainee. The Contractor shall also submit a Form 832 when any change in the employment status of a trainee occurs while the trainee is working on a project. The Project Engineer will not accept incomplete forms.

Form 832 provides space for listing the hours of on-the-job training received by a trainee on several projects. This permits CDOT to monitor the hours of trainees enrolled in the pilot program. The Project Engineer should pay only for the hours a trainee worked on the project. Trainee hours can be verified, if necessary, by comparison with certified payrolls.

The Contractor shall complete Form 832 as follows:

1. Type of Program. *Indicate the type of program.*
2. Contractor's Name, Project Number and Project Code (SA#). *Fill in as appropriate.*
3. Reporting Month. *Enter the month being reported.*
4. Trainee's Name, Classification, and Social Security Number. *Enter the trainee's name, work classification, and the last four digits of his social security number.*
5. Date Enrolled in Program and Hourly Rate. *Enter the date the trainee enrolled in the program and the trainee's hourly rate.*
6. Percent of Journeyman Scale. *Enter the trainee's hourly rate as a percentage of the journeyman scale.*
7. Total Hours Required in Program. *Enter the total hours required in the program.*
8. Status of Trainee. *Indicate the status of the trainee.*
9. Days and Hours Worked by Trainee this Month. *Enter the hours the trainee worked each day, broken down per CDOT project. Round the hours to the nearest half-hour.*
10. Non-CDOT Project Descriptions. *Enter the hours, if any, the trainee worked on non-CDOT projects.*

Appendix B

11. Total Training Hours Worked this Month. *Enter the total hours worked by the trainee this month.*
12. Previous Training Hours Worked. *Enter the total hours completed in the program prior to this Form 832. Include any hours credited for previous experience.*
13. Total Training Hours Worked to Date. *Enter the total hours completed in the program including this Form 832 and any credit for previous experience.*
14. Trainee's Primary Job Duties. *Provide a description of the trainee's primary job duties this month.*
15. Trainee's Overall Job Performance. *Indicate the trainee's job performance this month.*
16. Supervisor's Comments. *This entry reflects any comments the trainee's supervisor provides.*
17. Trainee's Signature. *If available, the trainee should sign in this cell.*
18. Supervisor's Signature. *The trainee's supervisor should sign in this cell.*
19. Contractor's Certification.
20. Project Engineer's Certification.

Appendix B

COLORADO DEPARTMENT OF TRANSPORTATION		Type of Approved Program Check all that apply:	
TRAINEE STATUS AND EVALUATION		<input type="checkbox"/> Standard	<input type="checkbox"/> Union
		<input type="checkbox"/> U.S. DOL-B	<input type="checkbox"/> Other: _____
Contractors Name: (2)		Project Number: (2)	Project Code (SA#): (2) Reporting Month: (3)
Trainee's Name: (4)		Trainee's Classification: (4)	
Last 4 of SSN (4)	Date Enrolled in Program: (5)	Hourly Rate: (5)	
Percent of Journeyman Scale: (6)	Total Hours Required in Program: (7)		
Status of Trainee (8) <input type="checkbox"/> Working <input type="checkbox"/> Graduated <input type="checkbox"/> Temporarily Laid Off <input type="checkbox"/> Dropped Out <input type="checkbox"/> Transferred to Another Project <input type="checkbox"/> Terminated			
Federal Aid: <input type="checkbox"/> Yes <input type="checkbox"/> No	CDOT Project No.: (9)	Project Code:	Location: Hours Worked this Month:
Federal Aid: <input type="checkbox"/> Yes <input type="checkbox"/> No	CDOT Project No.:	Project Code:	Location: Hours Worked this Month:
Federal Aid: <input type="checkbox"/> Yes <input type="checkbox"/> No	CDOT Project No.:	Project Code:	Location: Hours Worked this Month:
Federal Aid: <input type="checkbox"/> Yes <input type="checkbox"/> No	CDOT Project No.:	Project Code:	Location: Hours Worked this Month:
Non-CDOT Project Descriptions and Locations: (10)			Hours Worked this Month: (10)
Total Training Hours Worked This Month: (11)	Previous Training Hours Worked: (12)	Total Training Hours Worked to Date: (13)	
What were the trainee's primary job duties this month: (14)			
The trainee's overall job performance for this month is: <input type="checkbox"/> Excellent <input type="checkbox"/> Good <input type="checkbox"/> Fair <input type="checkbox"/> Poor (15)			
Supervisor's Comments: (16)			
Trainee's Comments:			
Trainee's Signature (if available): (17)		Supervisor's Signature: (18)	
CONTRACTOR:			
The undersigned contractor hereby certifies that the listed employee is a bona fide trainee as required by the On-the-Job Training Special Provision, that s/he has worked the hours reported on this form, and the hours worked on CDOT and Federal Aid Projects reported are eligible for reimbursement. The information provided above is reasonably correct to the best of my knowledge. (19)			
Contractor Signature/ Title			Date
PROJECT ENGINEER:			
I hereby certify that the On-the-Job training hours reported above have been reviewed and found reasonable.			
Engineer Signature/Title (20)		Date	

Distribution: REGION CIVIL RIGHTS MANAGER – 3 copies (one for BPO, one for Sponsor)
 Project Engineer
 Trainee
 Records Center (original)

Previous editions are obsolete and may not be used. CDOT Form # 832 12/11

Form 838 - OJT Trainee/Apprentice Record

Completion Instructions

Form 838 provides demographic data about individual trainees. The Contractor shall complete and submit Form 838 to the Project Engineer. The Project Engineer will not accept an incomplete Form 838. The Project Engineer will forward the Form 838 to the Region EEO/Civil Rights Specialist for review and approval. The Region EEO/Civil Rights Specialist will return an approved copy to the Project Engineer. The Project Engineer should not make payment for trainee hours until an approved Form 838 has been received from the Region EEO/Civil Rights Specialist.

After the Project Engineer receives an approved copy from the Region EEO/Civil Rights Specialist, the Contractor is eligible for reimbursement under the on-the-job training force account item, for each hour of training the approved trainee receives on the project. It is important that the Contractor provide information on all previous experience in the field for the trainee's previous construction work experience.

The Contractor shall complete Form 838 as follows:

1. Type of Program. Indicate the type of program.
2. Contractor's Name, Project No., Location, and Project Code (SA#). Fill in as appropriate.
3. Name and Title of Trainee's Supervisor.
4. Trainee Information. Enter the following information for the trainee:
 - a. name,
 - b. date,
 - c. job classification,
 - d. wage decision number,
 - e. sex,
 - f. last four digits of social security number,
 - g. veteran status,
 - h. education status,
 - i. training hours credited, and
 - j. ethnic or racial background.
5. Previous Construction Work Experience. It is important that the Contractor provide information on all the trainee's previous work experience.

Appendix B

6. Employment Dates. Enter the date the trainee was first employed by your company and the date you anticipate employment through.
7. Anticipated Employment Time. Enter the length of time anticipated.
8. Trainee's Beginning Wage Rate. Indicate the trainee's beginning wage rate.
9. Trainee's Preference to Travel. Indicate whether or not the trainee is willing to travel to continue employment.
10. Signature of Authorized Contractor Representative. Signature of Contractor or Designee.
11. Region Civil Rights Manager Signature. Signature and approval decision of the Region Civil Rights Manager.

COLORADO DEPARTMENT OF TRANSPORTATION OJT TRAINEE/APPRENTICE RECORD			
Contractor Instructions: 1) Complete this form for each trainee or apprentice on the project that will be used to meet OJT requirements 2) Submit one form for each trainee/ apprentice for each project 3) Retain a copy for your records 4) Submit original to CDOT Project Engineer 5) Incomplete submittals will be rejected 6) Attach training program certificate 7) Attach training enrollment certificate			
Type of Program (check all that apply): <input type="checkbox"/> Union <input checked="" type="checkbox"/> Standard OJT Program <input type="checkbox"/> Other _____ <input type="checkbox"/> U.S. DOL - BAT			
Contractor's Name: <i>XYZ Construction</i>	Project No.: <i>IR 70-1 (30)</i>	Location: <i>Idaho Springs</i>	Project Code (SA#): <i>80115</i>
Name of Trainee's Supervisor: <i>John Smith</i>		Title:	
Trainee's Name: <i>Jose Gonzales</i>		Date this form submitted: <i>10/29/2013</i>	
Trainee's Job Classification and CODE from the wage decision: <i>Carpenter 1010</i>		Wage Decision number, include modifications: <i>CO 2010004 M005</i>	
<input checked="" type="checkbox"/> Male <input type="checkbox"/> Female	Last 4 of SSN <i>0602</i>	Veteran: <input checked="" type="checkbox"/> No <input type="checkbox"/> Yes If Yes, which branch:	
Education – Check the last year of school completed: Highest Grade Completed _____ <input type="checkbox"/> GED <input checked="" type="checkbox"/> High School Diploma <input type="checkbox"/> College Technical Training or Certifications: Special Licenses:		Training Hours Credited: Accumulated: On-the-Job Training <i>120</i> (hours) Classroom Training _____ (hours)	
Ethnic or Racial Background: <input type="checkbox"/> African American <input type="checkbox"/> American Indian or Alaskan <input type="checkbox"/> White <input checked="" type="checkbox"/> Hispanic <input type="checkbox"/> Asian or Pacific Islander <input type="checkbox"/> Other			
Trainee's Previous Construction Work Experience:			
Name of Company <i>ABC Construction</i>	Location City / State <i>Grand Junction / Colo.</i>	Job Classification <i>Laborer</i>	Dates of Employment: From: <i>3/1/2011</i> To: <i>8/1/2011</i>
Were any previous jobs at the journeyman level? <input type="checkbox"/> Yes <input checked="" type="checkbox"/> No			
If yes, explain:			
Date Trainee First employed by Your Company: <i>9/1/2013</i>		How long do you anticipate employing this trainee/apprentice? <i>3 months</i>	
Date Enrolled in Training Program: <i>9/1/2013</i>			
Trainee's wage (% of journeyman work) at this time? <input checked="" type="checkbox"/> 60% <input type="checkbox"/> 75% <input type="checkbox"/> 90% <input type="checkbox"/> 100%		Trainee willing to travel? <input checked="" type="checkbox"/> Yes <input type="checkbox"/> No	
Trainees current wage rate \$ <i>19.27</i> /hr			
Signature of Authorized Contractor Representative: <i>John Smith</i>		Title:	Date: <i>10/29/13</i>
Region Civil Rights Manager Signature: <i>Stuart Little</i>		Region: <i>3</i> <input checked="" type="checkbox"/> Approved <input type="checkbox"/> Not-Approved	Date: <i>10/29/2013</i>
Comments or reason not approved:			

Previous editions are obsolete and may not be used.

CDOT Form # 838 12/11

Project Engineer (2) Project Engineer will provide one copy to the contractor
 Region Civil Rights Manager (3 copies – one for BPO; one for the sponsor if applicable)
 Records Center (Original)

Form 859 - Project Control Data

Completion Instructions

Review Section 108.8 of this *Manual* and the current Standard Specification Subsection 108.08, Determination and Extension of Contract Time before completing Form 859. Distribution of Form 859 should be completed two weeks prior to the scheduled advertisement date. The first page of Form 859 lists features for consideration when determining contract time. Complete the first page of Form 859 as follows:

1. Project No., Project Code (SA#), Location, and Region. *Enter the project number, project code, location, and Region number.*
2. Date. *Enter the date that information on the Form 859 is considered accurate. Any changes made after this date must be re-approved by the Program Engineer.*
3. Advertisement Period. *Enter the advertisement period, with three weeks being typical. The advertisement period may be adjusted to suit individual project requirements; however, the Chief Engineer must approve advertisement periods of less than three weeks.*
4. CDOT Personnel. *Enter the names of the individuals associated with the project.*
5. Floating Start Date. *Typically, this is No. If the project is to have a floating start date, select yes and enter the appropriate period in this cell.*
6. Lead Time. *Enter the lead time period in calendar days from the award date to the date shown on the Notice to Proceed Letter. This is typically 20 days, however, additional lead time may be allowed for individual project considerations such as material fabrication and delivery (e.g., traffic signals, luminaires, and steel fabrication), obtaining permits, and development of Contractor material sources, or scheduling partnering sessions. If a lead time is necessary, it will be included in the Project Special Provisions.*
7. Time Specification Considerations. *You will always select Yes for Critical Path. Check the applicable boxes for time considerations relative to contract time to be used on the project.*
8. Work Items that may Impact Contract Time. *Provide information in this section on the work items that may impact contract time. For example, ensure that the following issues are considered:*

Appendix B

- a. Lead time for construction survey work,
 - b. Utility relocations completed during construction,
 - c. Seasonal considerations including winter months, or winter shutdown,
 - d. Local events and traffic issues,
 - e. Temporary detour installation and removal, and
 - f. Planting season limitations.
9. *Flagging and Traffic Control. Enter the estimate for flagging and traffic control management quantities after completing a CPM schedule (see description below).*
 10. *Construction Type, Special Requirements, and Comments. Describe the type of construction and any special construction requirements or comments in this section of Form 859. This information is included to document the thought process for developing the contract Time.*
 11. *Days or Fixed Completion Date. Enter the number of contract days determined from a CPM Schedule or indicate the fixed completion date as appropriate.*
 12. *Months' Time Not Charged. Subsection 108.08 of the Standard Specifications does not allow free time. Any time period that time is not to be charged must be indicated in this cell and addressed in the Contract.*
 13. *Minor Contract Revisions. Enter the estimated dollar amount of minor Contract revisions to be reflected with project plan force accounts.*
 14. *Region Program Engineer Signature and Date. Form 859 will be signed and dated by the Region Program Engineer in these cells.*
 15. *Resident Engineer Signature and Date. Form 859 will be signed and dated by the Resident Engineer in these cells.*

Appendix B

Instructions for Completing a CPM Schedule

A Critical Path Method (CPM) schedule will be used to determine the contract time and attached to the Form 859. Microsoft Project is the software CDOT uses to develop the CPM schedule. The example below is a widening and Hot Mastic Asphalt overlay project. The following items of work are included in the project. The schedule begins when the Notice to Proceed is issued to the Contractor.

Bid Item Quantities:

- a. Construction Signing (ground mounted) 20 each
- b. Construction Surveying lump sum
- c. Clearing and Grubbing 10 acres
- d. Erosion Control installation 2 days #
- e. Utility Work (relocate power lines) 1 week
- f. Minor Structures (pipe extensions) 800 linear feet
- g. Unclassified Excavation (CIP) 40,000 cubic yards
- h. HMA (Grading SX)(100)(64-22) 15,000 tons
- i. Emulsified Asphalt (slow setting) 2,000 gallons
- j. Aggregate Base Course (Class 6) 6,000 tons
- k. Guardrail 5,000 linear feet
- l. Topsoil (H) 5,000 cubic yards
- m. Seeding (Native) 10 acres
- n. Mulching 10 acres
- o. Flagging * hours
- p. Traffic Control Management * days
- q. Traffic Control Inspection * days
- r. Pavement Marking Paint 170 gallons

While Erosion Control Installation is not a bid item, it is included to determine how it affects the Contract time.

*To be determined by the Resident Engineer and entered on Form 859.

1. List the items of work to be prosecuted. Listing these items of work in the logical sequence in which they must be performed will assist with completion of the CPM schedule.
 - a. Utility Locates
 - b. Mobilization and Construction Signing
 - c. Construction Surveying
 - d. Clearing and Grubbing

Appendix B

- e. Utility Work
- f. Minor Structures
- g. Unclassified Excavation
- h. HMA (Emulsified asphalt can be omitted, because it is controlled by HMA)
- i. ABC (ABC is for shouldering)
- j. Guardrail
- k. Topsoil
- l. Seeding (Mulching can be omitted, because it is controlled by seeding)
- m. Pavement Marking Paint.

Flagging, Traffic Control Management and Traffic Control Inspection are concurrent with the other work and do not affect project completion.

2. Determine which items are anticipated to be controlling items of work. A controlling item of work and a salient feature are not synonymous. A controlling item of work is an item of work that may extend the overall completion of the project if the duration of this item is increased. A salient feature is an item of work that may be of special interest in coordinating the project schedule because of the volume, complexity, or nature of the work, but may not affect the overall completion of the project.

In order to produce the schedule, the project should be constructed in theory to determine the sequence of the work, especially when phasing is required. Items of work can often be constructed concurrently which will also impact the duration of the project. Creating the CPM schedule will determine which items are controlling items of work for the project.

In this example, the following items are predicted to be controlling items of work:

- a. Utility Locates
- b. Construction Signing
- c. Construction Surveying
- d. Clearing and Grubbing
- e. Erosion Control Installation
- f. Minor Structures
- g. Unclassified Excavation
- h. HMA
- i. ABC
- j. Guardrail
- k. Topsoil
- l. Seeding and Mulching

- m. Striping
- n. Punch List

Construction signing is included as a controlling item to consider time for initial installation of ground-mounted advance warning signs, as indicated by the Traffic Control Plan. The construction signing work item is ongoing throughout the life of the project; however, initial placement of advance warning construction signs and required devices will be necessary prior to beginning construction surveying and other bid item work. In this example, mobilization is presumed to be completed in conjunction with construction signing and; therefore, time is not specifically addressed.

Lead time to initiate Construction Survey work should be considered to allow for checking of monuments and benchmarks and for slope staking to begin in advance of earthwork operations.

The remaining items are the primary work items required for completion of the project.

The utility work is anticipated to take five working days and is required to be completed in conjunction with unclassified excavation work, as the lines to be relocated are under ground. However, the utility company must be notified and the relocation completed in a timely manner to avoid delays. Therefore, these items are not controlling items of work, but rather are salient features. Final Striping (Pavement Marking Paint) can be completed while placing ABC, Topsoil, Seeding and Mulching.

3. Determine durations for items of work. Determine an estimated daily production rate for each controlling item of work, considering any factors that will impact completion as indicated on the first page of Form 859.

The estimated daily production rates used in the example below are specific only to this project and are not to be used for actual projects. Actual project production rates will vary based on location, accessibility, weather restrictions, working hour limitations, and traffic conditions.

To determine the number of work days required to complete each controlling item of work, divide the quantity of work for each item by the estimated daily production rate. Production rate calculations should be documented in the notes for each activity in the Microsoft Project file.

Appendix B

Computing Work Days for Controlling Items of Work			
<u>Item</u>	<u>Quantity</u>	<u>Estimated Daily Production Rate**</u>	<u>Work Days</u>
Utility Locates			1 day
Construction Signing	20 signs	10 signs/ day	2 days
Construction Surveying			15 days
Clearing and Grubbing	10 acres	1 acre/ day	10 days
Erosion Control Installation			2 days
Minor Structures (pipe ext. w/ end sections)	800 linear feet	50 linear feet/ day	16 days
Unclassified Excavation	40,000 cubic yards	2,000 cubic yards/ day	20 days
HMA	15,000 tons	1,000 tons/ day	15 days
ABC	6,000 tons	600 tons/ day	10 days
Guardrail	5,000 linear feet	300 linear feet/ day	17 days
Topsoil	5,000 cubic yards	500 cubic yards/ day	10 days
Seeding	10 acres	5 acres/ day	2 days
Striping			1 day
Punch List			3 days

**Notes on Production Rates:

- a. One work day for Utility Locates is considered reasonable.
- b. Fifteen days for Construction Surveying is considered reasonable, with three days lead time provided for checking of control monuments and initial slope stake placement in advance of clearing and grubbing, minor structure, and earthwork operations.
- c. Determination of the Construction Surveying duration and appropriate lead-time for actual projects will be based on survey complexity, engineering judgment, and experience with actual progress of survey work.
- d. Two days is considered reasonable for installing the first set of Erosion Control items.
- e. One work day is reasonable to perform final striping of the project.
- f. Three days is typical for completing Punch List items.

Appendix B

4. Create a CPM schedule. Create a new project in MS Project and enter the items of work as tasks. Adding the Notice to Proceed and Project Acceptance as milestones is helpful. Next add the estimated production rates and quantities in the notes, and the calculated durations in the appropriate box for each task. Finally add relationships between activities. If using relationships other than Finish to Start with zero lag, note the reasoning for using the different relationships and lags. All tasks or activities will have predecessor and successor activities except for the first activity (no predecessor), and the last activity (no successor).
5. It is helpful to create a summary activity that includes all project activities to calculate the number of days required to complete all project work.
6. The completed CPM Schedule shows that the contract time for this project should be 79 working days. Enter 79 working days in the proper box on the first page of Form 859.
7. In accordance with Section 630, a Traffic Control Management (TCM) day is paid for every calendar day on which there is active traffic control. In this example, the appropriate number of TCM days is 79 days. The elapsed time for the project which starts April 14, 2014 and ends August 7, 2014 is 117 days. In order to determine the Traffic Control Inspection (TCI) days, subtract the TCM days from the Elapsed time. In this example the difference is 38 days. Enter the TCM and TCI days in the comments section on the first page of Form 859.
8. To estimate the number of Flagging hours that will be required, estimate how many hours that will be required each day and multiply by the number of working days.
9. In this example, it was estimated that 948 hours of flagging would be required. Enter this amount on the first page of Form 859.

Appendix B

COLORADO DEPARTMENT OF TRANSPORTATION PROJECT CONTROL DATA	Project No.: EXAMPLE 1	Project Code (SA#): 1
	Location: Colorado 1	
	Region: 1	

The data on this form is valid for project advertisement before:		Date: 03/06/14 2	Advertisement Period: 3 weeks 3
Region Program Engineer: M. Wallace 4	Project Engineer: J. Winnfield 4		
Resident Engineer: B. Coolidge 4	Project Inspector: V. Vega 4		
Floating Start Date: <input type="checkbox"/> Yes <input checked="" type="checkbox"/> No / / to / / 5	Time Specification Considerations:		
Lead Time-Award Date to Notice-to-Proceed Date (typically 20 days): 6 20 days	Material Delivery: 7	Yes	No
	A+B:	<input type="checkbox"/>	<input checked="" type="checkbox"/>
	Critical Path:	<input checked="" type="checkbox"/>	<input type="checkbox"/>
	Completion Incentive/Disincentive:	<input type="checkbox"/>	<input checked="" type="checkbox"/>

Provide information below for work items that may impact Contract time. 8

Mobilization/Construction Signing: No Phasing Required	Construction Surveying: Provide Lead Time	Salient Feature: <input checked="" type="checkbox"/> Yes <input type="checkbox"/> No	
Clearing and Grubbing: Dense Tree Population	Utilities: Relocate buried power lines.	Detours – Installation: -----	Detours - Removal: -----
Minor Structures: pipe extensions only	Major Structures: -----		
Earthwork: <input type="checkbox"/> Contractor Furnished <input type="checkbox"/> Available Source 40,000	Borrow: <input type="checkbox"/> Contractor Furnished <input type="checkbox"/> Available Source -----		
Concrete Pavement: <input type="checkbox"/> Contractor Furnished <input type="checkbox"/> Available Source	Hot Bituminous Pavement: <input type="checkbox"/> Contractor Furnished <input type="checkbox"/> Available Source 15,000 ton		
QC/QA Specifications: <input checked="" type="checkbox"/> Yes <input type="checkbox"/> No If no, explain:	Smoothness Specifications: <input type="checkbox"/> No <input checked="" type="checkbox"/> Yes If yes, Category #: 3 HBP only: <input type="checkbox"/> % improvement <input checked="" type="checkbox"/> inches/mile		
Guardrail: Several Long Runs	Traffic Signals/Lighting: -----	Permanent Signing/Striping: Standard Pavement Marking	
Topsoil/Seeding/Mulching: Mountainous terrain	Other Items: ABC Shouldering 6,000 tons		
Flagging: 948 hours 9	Uniform Traffic Control: 0 hours 9	Traffic Control Manager: <input type="checkbox"/> No If no, attach explanation. 9 <input type="checkbox"/> Yes If yes, days: See Comments	

Construction Type, Special Requirements and Comments: 79 TCM days 38 TCI days 10			
--	--	--	--

Days: 79 <input checked="" type="checkbox"/> Working 11 <input type="checkbox"/> Calendar	Or Fixed Completion Date: 11 / /	Months Time Not Charged (free time): NA 12	Minor Contract Revisions: 10,000 13
Region Program Engineer Signature: 14	Date: 02/24/14 14	Resident Engineer Signature: 15	Date: 02/25/14 15

Distribution:
Records Center (original)
Region Program Engineer
Resident Engineer

Previous editions may be used until supplies exhausted

CDOT Form 859 Page 1 of 2 07/02

Appendix B

Note: Page 2 of Form 859, when printed from SiteManager®, is marked “Do Not Use.” As per the instructions, a Critical Path Method (CPM) schedule will be used instead of the second page of Form 859 to determine the Contract time. Microsoft Project is the software used to develop the CPM schedule.

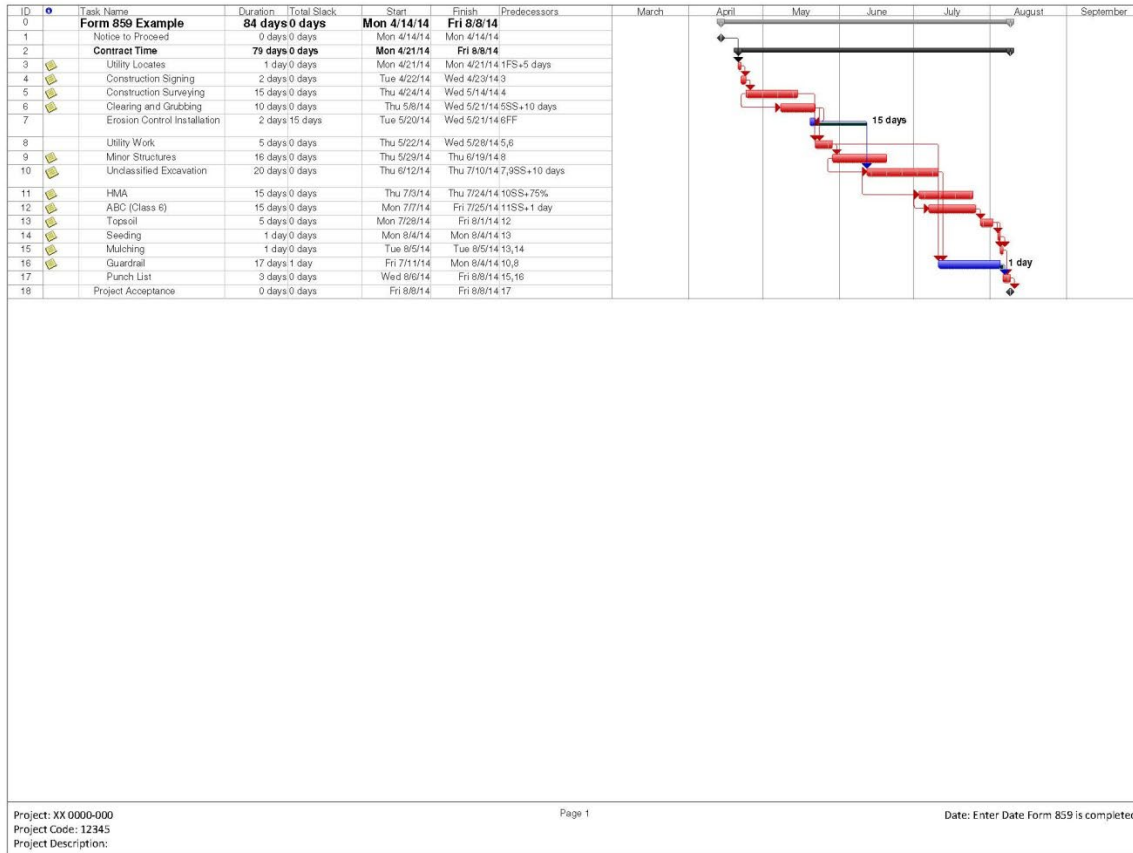

Form 1186 - Contract Funding Increase/Decrease and Approval Letter

Completion Instructions

Form 1186 must be submitted and approved prior to payment of any interim estimate that will cause the cumulative total of Contractor payments to exceed the project commitment amount. Form 1186 must be coordinated through the Region Business Office. See Section 120 of this *Manual* for additional information on when it is necessary to submit a Form 1186. Complete Form 1186 as follows:

1. Contracts/Situations. Indicate the contracts or situations that are applicable (e.g., CDOT construction, sum of contract modification orders, utility/railroad, underestimated total cost).
2. Section 1 Information. Enter the date, project code, project number, Region, office address of the requesting Business Office or residency, and the phone number and fax number of a contact person who can provide additional information concerning the request to increase or decrease funding.
3. Vendor Information. Enter the vendor's name, vendor's address, SAP vendor number, and the Contract routing number. The Contract routing number can be obtained from a copy of the signed Contract.
4. SAP Purchase Order Number, Fund, Functional Area:, GL Account Number, WBS Element or Functional Center. All information regarding SAP coding can be obtained from the Contract.
5. Original Contract Amount. Enter the original Contract amount, which can be obtained from the Contract.
6. Budget Request Processing. Indicate whether or not a budget request has been made through OFMB to cover the increased amount.
7. Previous Funding Letter(s) Total. Enter the previous funding letter(s) total, which is available from the project file.
8. Funding Letter Total. Enter the amount of this request.
9. Adjusted Contract Amount. Enter the adjusted Contract amount, which is the original Contract amount, plus any previous funding letters, plus this funding letter.

Appendix B

10. Contract Administrator's/Business Manager's Approval. The Region Business Manager must sign and list a phone number.
11. CDOT Designee Approval. The CDOT designee approval is no longer necessary.
12. Local Agency Approval. If it is a Local Agency Contract, the Region determines if the Local Agency approves.

The original must be sent to Accounting before the funds will be encumbered. Retain a copy of Form 1186 for the project file.

The Controller will sign and make the distribution as requested by the Region.

COLORADO DEPARTMENT OF TRANSPORTATION CONTRACT FUNDING INCREASE/DECREASE & APPROVAL LETTER	Authority: State Controller Policy letter on June 12, 1996 CDOT Controller letter on May 23, 1996
---	---

Region: Complete section 1 and submit to CDOT Controller's office

This form to be used for the following contracts/situations only (check the appropriate situation):			
<input checked="" type="checkbox"/> Indefinite quantity, order more/add more	<input type="checkbox"/> utility/railroad, underestimated total cost	<input type="checkbox"/> CDOT construction, sum of CMO's	<input type="checkbox"/> LA construction, underestimated cost
<input type="checkbox"/> CDOT Construction, underestimated total cost	<input type="checkbox"/> CDOT Consultant, underestimated cost	1	

SECTION 1 (Region use)

Date: 11/21/2013		Project code: 18070	
To: CDOT Controller {FAX# (303) 757-9573 or e-mail CONTROLLER}		Project #: FBR 0761-209	
From Region #: 1	Office: Region 1 Business Office	Phone #: 303-757-9913	FAX #: 303-757-9149
CDOT has executed a contract with: Sema Construction Inc.			
Address: 7353 S. Eagle Street, Centennial, CO 80112-4223			
CDOT Vendor #: 1004005	Contract routing #: 12 HA6 34522	SAP Purchase Order #: PO #261000871 PR #140002980	
Fund: 538	Functional Area: 3300	GL Account Number: 4231100011	WBS Element or Function Center: 18070.20.10
Original contract amount: \$ 11,677,190.15		Has a Budget Request been processed to cover the contract amount of increase? <input checked="" type="checkbox"/> Yes <input type="checkbox"/> No	
Previous Funding Letter(s) total: \$ -721,312.20	Funding letter: #1 thru # 1	Preparer's name: Kiersten Williams	Preparer's phone #: 303-757-9913
This Funding Letter total: \$ 107,749.00	Funding letter: # 2	Contract Administrator's/Business Manager's approval: Lillian Bourne	Approver's phone #: 303-757-9912
Adjusted contract amount: \$ 11,063,626.95		CDOT Designee approval: Masoud Ghaeli (Engineering PE III)	
		Local Agency approval:	

SECTION 2 (Controller's office use)

Total allotment amount: \$		Commission budget: \$	
If construction: <input type="checkbox"/> CE pool eligible	CE charges: \$	Indirect charges: \$	Adjusted contract amount plus total CE & Indirect charges Calculation: \$
I have reviewed the financial status of the project, organization, grant and have determined that sufficient funds are available to cover this increase, effective as of (show date):			
State Controller or Delegee:			Date signed:

Form 1212 - Final Acceptance Report

Completion Instructions

Form 1212 is used to document the final inspection of the project by the Resident Engineer, as required by FHWA on all Federal-Aid projects. The final inspection of the project should be completed in advance of project acceptance to permit any necessary corrective work to be completed before the Contractor vacates the project site. To facilitate coordination of the final inspection prior to project acceptance, the Resident Engineer will use transaction ZJ11 in SAP to complete items in Form 1212. SAP will execute the workflow and email a pdf copy to the Resident Engineer and the Finals Administrator. See Section 100 of this *Manual* for additional information on the use of Form 1212.

1. Project No., Project Code (SA#), and County. *Fill in as appropriate.*
2. Federal Oversight. *Check the appropriate response indicating whether or not the project has Federal-Aid oversight.*
3. Contractor's Name. *Enter the Contractor's name.*
4. Location. *Enter the project location.*
5. Original Contract Amount. *Enter the original Contract amount.*
6. Description of Improvement as Advertised. *Provide a description of the project improvement as advertised.*
7. Inspection Date. *Show the date that the project inspection was completed.*
8. Acceptance Date. *Enter the project acceptance date.*
9. Percent Time Elapsed. *Enter the percent of authorized Contract time elapsed as of the project acceptance date.*
10. Original Contract Time. *Input the number of original Contract days or the Contract completion date for the original Contract time.*
11. Checklist. *The Resident Engineer must check each box after verifying that the listed items are completed and correct. If any of the items on the checklist are not required for the project, the box should be left blank and an explanation entered on the form as to why the item was not required. In addition to the listed items that are discussed below, dollar amounts and time extensions associated with the claim resolutions may also be indicated as remarks.*

Appendix B

12. Name, Title, Signature, and Date. *The Resident Engineer's name and signature and the date are required.*

A hard copy with original signature must be forwarded to the FHWA via the Region Final's Engineer and a copy included in the project files even when using the electronic version of the form.

COLORADO DEPARTMENT OF TRANSPORTATION FINAL ACCEPTANCE REPORT FOR FEDERAL-AID PROJECTS		Project No.: 1 C 2911-003	Federal Oversight: 2 <input type="checkbox"/> Yes <input checked="" type="checkbox"/> No
		Project Code (SA#): 1 22859	County: CHAFFEE 1
Contractor's Name: 3 Western Gravel Constructors, L	Location: 4 Salida Pedestrian Improvements	Original Contract Amount: 5 \$ 1,127,477.00	
Description of Improvement as Advertised: ADA RAMPS AND OTHER IMPROVEMENTS IN SALIDA 6			
Inspection Date: 7 03/14/2022	Acceptance Date: 8 / /	Percent Time Elapsed: 9 89.00 %	Original Contract Time: 10 75 days
<p>Checklist--Verify the following items as complete and/or correct: 11</p> <ul style="list-style-type: none"> <input type="checkbox"/> The project has been completed in reasonably close conformity with the Contract Plans and specifications including authorized changes. <input type="checkbox"/> The Form 473 - Letter of Materials Certification has been completed <input type="checkbox"/> The project right-of-way appears to be free of unauthorized encroachments. <input type="checkbox"/> The completed project has been reviewed for obvious safety deficiencies. <p>Select one of the following:</p> <ul style="list-style-type: none"> <input type="checkbox"/> 1. The project did not include work on bridges or culverts with a span (or diameter)\geq4', tunnel, walls over 4' high, traffic signal structure and/or overhead sign structure (Stop, if selected) <input checked="" type="checkbox"/> 2. The project included work on bridges or culverts with a span (or diameter)\geq4', tunnel, walls over 4' high, traffic signal structure and/or overhead sign structure. <p>If you selected 2 above confirm the following:</p> <ul style="list-style-type: none"> <input checked="" type="checkbox"/> All Structures: Staff Bridge or Engineer of Record has conducted a final inspection (walk-through) of all structures on this project and determined the work is in reasonably close conformity with the plans and specifications. Supporting documentation shall include any structure related items to be addressed along with photos and date of inspection. <input type="checkbox"/> Bridge/Culvert\geq20' long or Tunnel: The CDOT Bridge & Structure Inspection and the Asset Management Engineer has been contacted for required NBIS/NTIS inspections. <p><small>See Bridge Design Manual(Policies & Procedures,P3:Staff Bridge Managed Structural Assests) for definitions.</small></p> <p>Remarks: Selected 2 and submitting with all structures</p>			
Name: ZOJERAJ 12 Title: Resident Engineer		Date: 12 03/14/2022	

Previous editions are obsolete and may not be used

CDOT Form 1212 02/22

Distribution:

- | | |
|--------------------------|--|
| FHWA (Original) | Local Agency (if a Local Agency Project) |
| CDOT Projects and Grants | Staff Bridge Asset Management Engineer |
| Projectwise | Staff Bridge Region Unit Leader |
| Finals Engineer | Staff Bridge Portfolio Manager |
| Resident Engineer | |

COLORADO DEPARTMENT OF TRANSPORTATION FINAL ACCEPTANCE REPORT FOR LOCAL AGENCY PROJECTS		Project No.: BRO C010-114 (1)	Federal Oversight: (2) <input type="checkbox"/> Yes <input checked="" type="checkbox"/> No
		Project Code (SA#): 20414 (1)	County: JEFFERSON (1)
Contractor's Name: Testing LA Contractor (3)	Location: (4) EVERGREEN LAKE RD OVER BEAR CREEK		Original Contract Amount: (5) \$ 762,000.00
Description of Improvement as Advertised: REMOVE AND REPLACE STRUCTURE (6)			
Inspection Date: (7) 03/14/2022	Acceptance Date: (8) 01/21/2022	Percent Time Elapsed: (9) 90.00 %	Original Contract Time: (10) 300 WORKING days
Checklist--Verify the following items as complete and/or correct: (11) <ul style="list-style-type: none"> <input type="checkbox"/> The project has been completed in reasonably close conformity with the Contract Plans and specifications including authorized changes. <input type="checkbox"/> The Form 473LA - Letter of Materials Certification has been completed <input type="checkbox"/> The project right-of-way appears to be free of unauthorized encroachments. <input type="checkbox"/> The completed project has been reviewed for obvious safety deficiencies. Select one of the following: <ul style="list-style-type: none"> <input type="checkbox"/> 1.The project did not include work on bridges or culverts with a span(or diameter)>=4',tunnel, walls over 4' high,traffic signal structure and/or overhead sign structure.(Stop, if selected) <input checked="" type="checkbox"/> 2. The project included work on bridges or culverts with a span (or diameter)>=4',tunnel,walls over 4' high, traffic signal structure and/or overhead sign structure. If you selected 2 above confirm the following: <ul style="list-style-type: none"> <input checked="" type="checkbox"/> All Structures: The Local Agency's Licensed Engineer in Responsible Charge of Construction(EIRC) has conducted a final inspection (walk-through) of all structures on this project and determined the work is in reasonably close conformity with the plans and specifications.(The Engineer of Record is an acceptable substitute for the ERIC).Supporting documentation shall include any structure related items to be addressed along with photos and date of inspection. <input checked="" type="checkbox"/> Bridge/Culvert>20' long or Tunnel: The CDOT Bridge Structure Inspection and the Asset Management Engineer has been contacted for required NBIS/NTIS inspections. See Bridge Design Manual(Policies & Procedures,P3:Staff Bridge Managed Structural Assests) for definitions. <p>Remarks: Selected 2 and it will require the end user to select All Structures before submitting the form.</p>			
Name: ZOJERAJ Title: Resident Engineer (12)		Date: 03/14/2022 (12)	

Previous editions are obsolete and may not be used

CDOT Form 1212 LA 02/22

Distribution:

- | | |
|--------------------------|--|
| FHWA (Original) | Local Agency (if a Local Agency Project) |
| CDOT Projects and Grants | Staff Bridge Asset Management Engineer |
| Projectwise | Staff Bridge Region Unit Leader |
| Finals Engineer | Staff Bridge Portfolio Manager |
| Resident Engineer | |

Form 1318 - Dispute and Claim Status Report

Completion Instructions

The Project Engineer is responsible for completing the Dispute and Claim Status Report. See Section 105.22 of this *Manual* for additional information on claims. Complete the Claims Status Report as follows:

1. Date of Report. *Date of first instance.*
2. Claim No. Number consecutively on the project. *Enter both claim number and dispute number as per the example. You may have had four disputes on the project, but this is the first dispute that went to claim status; the Claim No. would be "1-D4" to tie the claim to the dispute.*
3. Project No., Project Code (SA#), and Project Description. *Fill in as appropriate.*
4. Final Acceptance Date. *Date the project was accepted.*
5. Contractor Information. *Fill in as appropriate.*
6. CDOT Contacts. *Fill in as appropriate.*
7. Work Category. *As instructed, enter the Standard Specification which addresses the disputed item (i.e. 203.06 Embankment.)*
8. Primary Basis of Dispute. *Enter the primary reason for the dispute (i.e. CDOT and the Contractor could not agree on time allowance, cost, interpretation of plans, etc.).*
9. Brief Description of Dispute. *Fill in as appropriate.*
10. Amount of Contractor's Dispute. *If amount of dispute is unknown at the time of notice, put "unknown" until amount is determined. Amount of Contractor's dispute must be determined when their Request for Equitable Adjustment (REA) is submitted.*
11. Amount of Contractor's Dispute. *If time of dispute is unknown at the time of notice, put "unknown" until the number of days is determined. Amount of time related to Contractor's dispute must be determined when their Request for Equitable Adjustment (REA) is submitted.*
12. Event. *Fill in the dates as each item transpires. The days listed after each line item denote the time frame when that line item is due based on the preceding process*

Appendix B

completed. Schedule of dispute is critical; dispute may be granted or denied is CDOT or the Contractor fail to follow the schedule outlined in subsection 105.22 of the Standard Specifications.

13. *Level. Level denotes the level the dispute/claim was resolved.*
14. *Comments. Fill in as appropriate.*

Appendix B

COLORADO DEPARTMENT OF TRANSPORTATION DISPUTE AND CLAIM STATUS REPORT (STANDARD SPECIFICATION 105.22)		Date of Report: 1	Region:
		Dispute No.:	Claim No.: 2 (Claim – Dispute)
		Project Code:	(i.e. Claim #1 Dispute #4, 1-D4)
		Project Number: 3	
		Project Description:	
		Final Acceptance Date: 4	
Contractor:		Contract Amount:	
Address: 5		Contractor Contact:	
Phone:	Cell:	Fax:	
CDOT Contacts: 6	Phone Numbers		
	Office	Mobile	Field
Region Program Engineer:			
Resident Engineer:			
Project Engineer:			
Area Engineer:			
Work Category (which section of Standard Specifications, ie 203.06): 7			
Primary Basis of Dispute: 8			
Unanticipated Condition:			
Brief Description of Dispute: 9			
Any Additional Information:			
Amount of Contractor's Dispute: 10		Time Disputed: 11 days	
Event	Date Completed	Date Scheduled	
Immediate Oral Notice of Project Issue Impasse CDOT Rep. Notified:			
Written Notice of Dispute [105.22(b)]		12	
Contractor's Submittal of Request for Equitable Adjustment(REA)[105.22(b)] 15 days			
Project Engineer Furnishes Complete REA Package to Area Engineer ASAP			
Project Engineer and Contractor Discuss merit of dispute [105.22(c)] 15 days after submittal			
Project Engineer's Written Decision [105.22(c)] 7 days			
PE determines dispute has merit			
Merit granted Quantum negotiations [105.22(c)] 30 days			
Contractor Agrees __ or Disagrees __ on Quantum (Check appropriate item) 7 days		If Agrees GOTO	Dispute Resolved
Contractor rejects PE denial __ or Disagrees on Quantum __ (Check appropriate item)			
Contractor provides written notice to Resident Engineer [105.22(d)] 7 days			
PE/RE & Supt/PM & Contractor's rep with decision authority above the project level to meet regularly to discuss dispute [105.22(d)] Up to 30 days			
Contractor Agrees __ or Disagrees __ (Check appropriate item) 7 days		If Agrees GOTO	Dispute Resolved
Project Engineer initiates Dispute Resolution Board (DRB) process [105.23(a)] 5 days			
DRB Agreement Signed [105.23(b)] 30/45 days			
DRB Prehearing Submittal [105.23(e)] 20 days			
DRB Hearing [105.23(f)] 10 days			
DRB Renders a Recommendation [105.23(g)] 30 days			
Request for Clarification and Reconsideration [105.23(h)] 10 days			
Either Party Rejects __ or Accepts __ Recommendation (Check appropriate item) [105.23(i)] 14 days			

CDOT FORM #1318 04/12

Appendix B

DRB Recommendations Accepted	If Agrees GOTO	Dispute Resolved
Contractor Files Notice of Intent to File a Claim to the Region Transportation Director (RTD) [105.24(a)] 30 days		
Contractor submits claim package w/RTD (and Audit Unit if Over \$250K) [105.24(b)] 60 days		
RTD Renders a Decision [105.24(d)] 60 days		
Contractor Accepts __ or Rejects __ RTD Decision (Check appropriate item) [105.24(d)] 30 days		
RTD Recommendations Accepted	If Agrees GOTO	Dispute Resolved
Contractor Rejects and Appeals RTD decision to Chief Engineer (CE)		
Chief Engineer Renders Decision [105.24(e)] 60 days		
Or - Contractor May Request Hearing with CE [105.24(e)] 15 days		
Chief Engineer Renders Decision After Hearing [105.24(e)] 45 days		
Contractor Accepts __ or Rejects __ CE Decision (Check appropriate item) [105.24(e)] 30 days		
CE Recommendations Accepted	If Agrees GOTO	Dispute Resolved
Contractor Initiates one of the following based on Form 1378 at time of pre-construction meeting 180 days		
Merit Binding Arbitration		
De Novo Litigation		
Dispute Resolved: Adjustment of Payment/Schedule in Consultation with Program Engineer		
Claim Settled for \$ _____ Time Claimed: _____ days Level: 13		
Comments: (Please furnish all new information about the claim since the last report.)		
14		
Partnering/Dispute Resolution in place (yes/no)		If yes, was it attempted (yes/no)
Reason CDOT believes agreement not achieved:		
Project Being Audited (yes / no)		Completion Date

FHWA Form 1391 - Federal-Aid Highway Construction Contractors Annual EEO Report

Completion Instructions

A blank copy of FHWA Form 1391 is presented on the next page for reference and at this link [FHWA Form 1391](#).

An electronic version of the Form FHWA 1391 (Rev. 09-13) Excel workbook is embedded here:



FHWA 1391.xlsx

FEDERAL-AID HIGHWAY CONSTRUCTION CONTRACTORS ANNUAL EEO REPORT																						
1. MARK APPROPRIATE BLOCK <input type="checkbox"/> Contractor <input type="checkbox"/> Subcontractor			2. COMPANY NAME, CITY, STATE:			3. PROJECT NUMBER:			4. DOLLAR AMOUNT OF CONTRACT:			5. PROJECT LOCATION: (County and State)										
This collection of information is required by law and regulation 23 U.S.C. 140a and 23 CFR Part 230. The OMB control number for this collection is 2125-0019 expiring in August, 2019.																						
6. WORKFORCE ON FEDERAL-AID AND CONSTRUCTION SITE(S) DURING LAST FULL PAY PERIOD ENDING IN JULY 20__ (INSERT YEAR)																						
JOB CATEGORIES	TOTAL EMPLOYED		TOTAL RACIAL/ ETHNIC MINORITY		BLACK or AFRICAN AMERICAN		HISPANIC OR LATINO		AMERICAN INDIAN OR ALASKA NATIVE		ASIAN		NATIVE HAWAIIAN OR OTHER PACIFIC ISLANDER		TWO OR MORE RACES		WHITE		APPRENTICES		ON THE JOB TRAINEES	
	M	F	M	F	M	F	M	F	M	F	M	F	M	F	M	F	M	F	M	F	M	F
OFFICIALS	0	0	0	0																		
SUPERVISORS	0	0	0	0																		
FOREMEN/WOMEN	0	0	0	0																		
CLERICAL	0	0	0	0																		
EQUIPMENT OPERATORS	0	0	0	0																		
MECHANICS	0	0	0	0																		
TRUCK DRIVERS	0	0	0	0																		
IRONWORKERS	0	0	0	0																		
CARPENTERS	0	0	0	0																		
CEMENT MASONS	0	0	0	0																		
ELECTRICIANS	0	0	0	0																		
PIPEFITTER/PLUMBERS	0	0	0	0																		
PAINTERS	0	0	0	0																		
LABORERS-SEMI SKILLED	0	0	0	0																		
LABORERS-UNSKILLED	0	0	0	0																		
TOTAL	0	0	0	0	0	0	0	0	0	0	0	0	0	0	0	0	0	0	0	0	0	0

TABLE C (Table B data by racial status)																													
APPRENTICES	0	0	0	0																									
OJT TRAINEES	0	0	0	0																									
8. PREPARED BY: (Signature and Title of Contractors Representative)															9. DATE														
10. REVIEWED BY: (Signature and Title of State Highway Official)															11. DATE														

Form 1401 - Block Faced MSE Wall Submittal Checklist

A blank copy of Form 1401 is presented.

COLORADO DEPARTMENT OF TRANSPORTATION BLOCK FACED MSE WALL SUBMITTAL CHECKLIST	Project No.:
	Project Code (SA#):
	Date:

Instructions for shop drawing submittal and approval:

- This form is to be used on projects that require construction of Concrete Block Facing MSE Walls or alternate hybrid walls. The Contractor is to fill out this form and submit it with the shop drawings.
- Yes = Yes, the required submittal is included in this submittal package.
- No = No, the required submittal is not included in this submittal package. Provide the reason why the required submittal is not included in this submittal package in the space below the requirement. This may result in the rejection of the submittal package.
- NA = The required submittal does not apply. In lieu of required submittal provide alternative documentation as needed. Provide reason why in the space below the requirement.
- Add = The required submittal is not available at this time. Provide planned date when test results will be provided in the space below the requirement.
- (1) = An explanation is required and has been provided in the space below the requirement.

Contractor's Name:
Subcontractor's Name:
Description of Wall(s):

Standard Special Provision Reference	Requirement Description (see Standard Special Provision for complete description and requirements)	Enter Yes, No (1), NA (1) and/or Add (1)
MATERIALS, (f) 1	Certification of TULT (MARV) conforming to the requirements of ASTM D4595, ASTM D6637 or other methods as appropriate.	
MATERIALS, (f) 1	Ultimate Tensile Strength, a mill test report containing the ultimate tensile strength and/or yield strength of the steel.	
MATERIALS, (f) 2	Report of the block/reinforcement connection test conforming to the requirements of ASTM D6638, NCMA Methods SRWU 1 or other methods as appropriate.	
MATERIALS, (f) 3	Report for block/block connection test conforming to the requirements of NCMA Methods SRWU 2 or other methods as appropriate.	
MATERIALS, (f) 4	Report for soil to reinforcement interface pullout test conforming to the requirements of ASTM D6706 or other methods as appropriate.	
MATERIALS, (f) 5	Certification of facial block to reinforcement long-term connection strength.	
MATERIALS, (f) 6	Certification of reinforcement pullout.	
MATERIALS, (f) 7	Report and certification for Concrete block 28 days compression strength and water absorption rate conforming to the requirements of ASTM C90 and ASTM C140. Multiple submittals may be required per frequency of tests.	
MATERIALS, (f) 8	Efflorescence, Freeze and Thaw Test conforming to the requirements of ASTM C1262 or other methods as appropriate. Multiple submittals may be required per frequency of tests.	

I certify that the Block Faced MSE Wall Certifications, Calculations and Testing Reports Submittal is complete and correct.	
Authorized Prime Contractor Representative Signature:	Title:

Form 1402 - Panel Faced MSE Wall Submittal Checklist

A blank copy of Form 1402 is presented.

COLORADO DEPARTMENT OF TRANSPORTATION PANEL FACED MSE WALL SUBMITTAL CHECKLIST	Project No.:
	Project Code (SA#):
	Date:

Instructions for shop drawing submittal and approval:

- This form is to be used on projects that require construction of Concrete Panel Facing MSE Walls or alternate hybrid walls. The Contractor is to fill out this form and submit it with the shop drawings.
- Yes = Yes, the required submittal is included in this submittal package.
- No = No, the required submittal is not included in this submittal package. Provide the reason why the required submittal is not included in this submittal package in the space below the requirement. This may result in the rejection of the submittal package.
- NA = The required submittal does not apply. In lieu of required submittal provide alternative documentation as needed. Provide reason why in the space below the requirement.
- Add = The required submittal is not available at this time. Provide planned date when test results will be provided in the space below the requirement.
- (1) = An explanation is required and has been provided in the space below the requirement.

Contractor's Name:
Subcontractor's Name:
Description of Wall(s):

Standard Special Provision Reference	Requirement Description (see Standard Special Provision for complete description and requirements)	Enter Yes, No (1), NA (1) and/or Add (1)
MATERIALS, (f) 1	Certification of T_{ULT} (MARV) conforming to the requirements of ASTM D4595, ASTM D6637 or other methods as appropriate.	
MATERIALS, (f) 2	Ultimate Tensile Strength, a mill test report containing the ultimate tensile strength and/or of yield strength of the steel.	
MATERIALS, (f) 3	Report of the Panel/Reinforcement Connection Test.	
MATERIALS, (f) 4	Report for soil to reinforcement interface pullout test conforming to the requirements of ASTM D6706 or other methods as appropriate.	
MATERIALS, (f) 5	Certification of facial panel to reinforcement long-term connection strength	
MATERIALS, (f) 6	Certification of reinforcement pullout	
MATERIALS, (f) 7	Certification of the initial concrete compression strength and Report of shipping and handling stress calculations	
MATERIALS, (f) 8	Design calculations and/or pull out test report for soil reinforcement embedment in the concrete panel	
MATERIALS, (f) 9	Air Content Test conforming to the requirements of ASTM C173 or ASTM C231. Multiple submittals may be required per frequency of tests.	

I certify that the Panel Faced MSE Wall Certifications, Calculations and Testing Reports Submittal is complete and correct.	
Authorized Prime Contractor Representative Signature:	Title:

Piling Form

Completion Instructions

Complete the Piling Form as follows:

1. Project No. and Project Code (SA#). *Fill in as appropriate.*
2. Date. *Enter the date the piling was driven into the ground.*
3. Piling Site No. *Make a copy of the piling layout from the plans. The sites of the piling will be numbered beginning with Abutment 1, continuing to Pier 2. Write the piling site number corresponding to the piling to be driven.*
4. Pile No. *Record a number if a cutoff is being spliced to the pile. The pile number to be used will be the piling site number followed by an "A" of the site it was cut from.*
5. Heat No. *Enter the heat number. The heat number is the number recorded on the piling.*
6. Linear Feet. *Enter the data for linear feet as follows:*
 - a. In Lead. *The length of the piling that has been driven.*
 - b. Cut Off. *The length of the piling that has been cut off.*
 - c. In Place (a). *The lead length minus the cutoff length.*
7. Splices. *Enter the data for splices as follows:*
 - a. No. *Enter the total number of splices on the piling. Check the specifications for the total number of splices allowed for payment.*
 - b. X. *Enter the length allowed for splices per the Standard Specifications.*
 - c. Linear Feet (b). *Enter the number of splices multiplied by the X length.*
8. Item 502 Total Linear Feet (c). *Enter the sum of column (a) and column (b).*
9. Item 900 *Cutoff $L \leq 10$ feet. *Enter the cutoff length not used that is less than or equal to 10 feet. Add a new item to the Contract. The unit price for the new item is based on using 80% of the Contract unit price per subsection 502.13 of the Standard Specifications.*
10. Calculated By. *The initials of the Project Inspector who is documenting the piling quantities are entered in this column.*

Appendix B

11. *Checked By. The initials of the Project Inspector who checks the piling quantities are entered in this column.*

COLORADO DEPARTMENT OF TRANSPORTATION PILING FORM												
		Project No.: ① Example		Project Code (SA#): ① 11111						Checked By ⑪		
② Date	③ Piling Site No.	④ Pile No.	⑤ Heat No.	⑥ Linear Feet			⑦ Splices		⑧ Item 502 Total Linear Feet (c)	⑨ Item 900 *Cutoff L ≤ 10 feet	⑩ Calculated By	
				In Lead	Cut Off	In Place (a)	No.	X				Linear Feet (b)
6/1/95	11		245810	42.4		42.4			42.4			
6/1/95	11		245810	36.3	17.2	19.1	1	2	21.1			
6/1/95	12		245810	42.4		42.4			42.4			
6/1/95	12	11A	245810	17.2	5.6	11.6	1	2	13.6	5.6		
/ /												
/ /												
/ /												
/ /												
/ /												
/ /												
/ /												
/ /												
/ /												
/ /												
									TOTAL:	119.2	5.6	Sheet No.:

*Paid as a new item per subsection 502.13 of the Standard Specifications.

Distribution: Project File (original)

CDOT Piling Form 07/02

Traffic Control Review Form

An example of Traffic Control Review Form is presented.

The seven-page printed version that follows is a sample. The fillable Excel spreadsheet is embedded below.



Master TCR -
wTeamWeighting.xls

Appendix B

Project: FBR 114A-010
 Subaccount: 12345
 Location: SH 114 over Jackson Creek

Date: May 24, 2019
 Time: 10:15 AM

Project Engineer: S. Standard
 Resident Engineer: P. Manning
 Reviewer: TC Review Team

Prime Contractor: W.R. Bridges
 Traffic Control Contractor: TC Specialist
 Traffic Control Supervisor: S. Stripes

Use Yes, No, NA (Not Applicable), or NC (Not Checked)

[NOTE: References are to CDOT's current Standard Specifications, standard special provisions (SSP), Construction Bulletins (CB), M&S standards (M- or S-xxx-x), Construction Manual (CM), Manual on Uniform Traffic Control Devices (MUTCD), AASHTO Roadside Design Guide (RDG), or Work Zone Safety and Mobility Rules Procedural Document (MRPD), Flagger Manual. Lighter shaded items indicates part of the office review.]

I. TRAFFIC CONTROL MANAGEMENT (Wt. = 1)	Yes	No	NA	NC	Score	Total Poss.
A. TCS's Traffic control daily diaries on file (630.11(5)).	X				1	1
B. Discrepancies...noted in diary, CDOT Form 7 & corrected (630.11(5)(xi)).	X				1	1
C. Night inspections conducted weekly, documented (630.11(6)).	X				1	1
D. MUTCD (Current) in CDOT field office (CM 630.3.1 #1).						
E. Public Info. Spec implemented as required, including up-to-date phone message, daily phone call log, fliers, etc. (Project Special Provision 626, 630.10(c)).		X			0	1
F. Manufacturer's written NCHRP 350 certification for each work zone device before it is first used on the project.	X				1	1
G. Transportation Management Plan on file and includes TCP, TO, and PI (630.10).	X				1	1
H. Contingency Plans included that are consistent with Traffic Incident Management Plan (MRPD, Section 7, P. 19).	X				1	1
I. Flagging and TCS Certifications on file in Field Office (630.11, 630.14).	X				1	1
J. Team Weighting						
Section Score (Sum X Wt)					7	8

Section I Comments.

E. Public Information message was not current. Please note: message was updated prior to leaving project.

Appendix B

II. METHOD OF HANDLING TRAFFIC (MHT) (Wt. =2)	Yes	No	NA	NC	Score	Total Poss.
A. MHT on file in project records, for each work zone operation (630.10(a)).	X				2	2
B. All CDOT Personnel and superintendents have received TCS training (Policy Memo 22).	X				2	2
C. Current active MHT(s) in compliance per 630.10(a).	X				2	2
D. MHT reviewed and initialed by Prime contractor (CM 630.2.4 #1).	X				2	2
E. MHT approved and initialed by proper CDOT person (630.10(a)).	X				2	2
F. MHT sufficiently detailed per 630.10.						
1. Detailed diagram (630.10(a)(1)).	X				2	2
2. Tabulation of devices for each phase (630.10(a)(2)).		X			0	2
3. MUTCD, Plans, Specs & other sources referenced (630.10(a)(4)).	X				2	2
4. Estab. access mtce. plan, turn around locs., equip. storage, etc. (630.10(a)(5)).	X				2	2
5. Pedestrian (ADA), bicycle & non vehicular access addressed (630.10(a)(6)).	X				2	2
6. Plan for emergency vehicle access (630.10(a)(7)).	X				2	2
G. Vert. and horiz. clearances verified by field survey by Contractor, CM 630.2.4, #7a, 7b & 7c, (630.10(8)&(9)).			X			
H. Team Weighting						
Section Score (Sum X Wt)					20	22

Section II Comments.

F2 No tabulation of devices for Phase III.

Appendix B

III. WORKSITE TRAFFIC CONTROL SUPERVISOR (TCS) (Wt. =1)	Yes	No	NA	NC	Score	Total Poss.
A. Current ATSSA or CCA Certification on file in project records (630.11).	X				1	1
B. TCS has current flagger card (630.11).	X				1	1
C. TCS available on project (630.11, last paragraph).	X				1	1
D. TCS has current MUTCD (630.11(8)). (Electronic copy acceptable if internet access is not required to access it.)	X				1	1
E. TCS has current TCP, MHT, M&S-Standards and revisions (630.11(8)). (Electronic copy acceptable if internet access is not required to access it.)	X				1	1
F. TCS appropriately dressed (fluorescent orange-red or yellow-green hardhat, vest, reflectorization at night, sturdy boots - appropriate PPE)(630.14).	X				1	1
G. Team Weighting						
Section Score (Sum X Wt)					6	6
Section III Comments.						

IV. FLAGGERS (Wt. = 1) (see MUTCD Chapter 6E)	Yes	No	NA	NC	Score	Total Poss.
A. Current flagger card (630.14(a))				X		
B. Appropriately dressed (fluorescent orange-red or yellow-green hardhat, vest, reflectorization at night, sturdy boots). (630.14) (appropriate PPE).	X				1	1
C. Proper flagging methods used (630.14, MUTCD 6E.07).	X				1	1
D. Flagger location (630.14, MUTCD 6E.08).						
1. Visible to traffic.	X				1	1
2. Proper distance in advance of work.	X				1	1
3. Station illuminated at night (630.14).			X			
E. "STOP/SLOW" Paddle (MUTCD 6E.03).						
1. Correct size and shape.	X				1	1
2. Satisfactory condition.		X			0	1
3. Correct sheeting (Type III or fluorescent).	X				1	1
F. Team Weighting						
Section Score (Sum X Wt)					6	7
Section IV Comments.						

E2. Stop/Slow paddle was past it's useful life, terrible condition. TCS replaced and put the unacceptable paddle out of service.

Appendix B

V. CONSTRUCTION/MAINTENANCE SIGNING (Wt. = 3)	Yes	No	NA	NC	Score	Total Poss.
A. Placement (spacing/mounting height/angle/offset/sight distance) conforms to approved MHT/MUTCD/S-Stds.		X			0	3
B. Conforms to MUTCD/S-Standards/TC plans (size, layout, color).	X				3	3
C. Temporary Signs.						
1. 1' minimum above pavement elevation (S-630-1, Sheet 1, note 12).	X				3	3
2. Stored out of clear zone (630.13).		X			0	3
D. Satisfactory condition (clean, readable, no wear/tear/wrinkling/bowing).	X				3	3
E. Satisfactory breakaway posts or NCHRP 350 compliant (614.02, 630.02, 630.09, SSP 630, CM 630.3.4).	X				3	3
F. Correct signing for situation.	X				3	3
G. Conflicting signs properly treated (masked, turned, removed) (630.12,630.13).			X			
H. Appropriate fluorescent & reflective sheeting on all signs. (630.02).	X				3	3
I. Flashing beacons installed/working properly (S-614-14)(S-630-3).				X		
J. VMS message/placement (MUTCD 6F.60, MUTCD 1A.15).			X			
K. Team Weighting						
Section Score (Sum X Wt)					18	24

Section V Comments.

A. Signs out of order NB SH114 MM 22. G20-1 should be placed before W20-1

C2. Signs staged in the clear zone for utility work SH 114 at mm 24.5 SB for work later in the afternoon can not be stored in the clear zone. TCS picked up and put on truck after they were informed they could not store unused signs in the clear zone.

Appendix B

VI. TRAFFIC CONTROL DEVICES (Wt. =3)	Yes	No	NA	NC	Score	Total Poss.
A. Arrow panel (MUTCD 6F.61, 630.03).						
1. Correct size, number of lights etc.	X				3	3
2. Correct mounting height.	X				3	3
3. Correct placement.	X				3	3
4. All lights working.	X				3	3
5. Correct operating mode.	X				3	3
6. Auto dimmer for night use operational.				X		
B. Channelizing devices (barricades, cones, drums, etc.) (630.05, 630.06, MUTCD 6F.63 to 6F.68):						
1. Correct dimensions.	X				3	3
2. Clean, adequately maintained, and functional (upright, etc.).	X				3	3
3. Correct taper length.	X				3	3
4. Correct spacing between devices.	X				3	3
5. Warning lights working.			X			
C. Concrete barrier (temporary):						
1. Correctly pinned. (630.08, M-606-14, RDG 9.2.1.1).			X			
2. Proper reflector spacing. (S-630-2 Note 9, max 50 feet).			X			
3. Proper reflector color (S-612-1, Note 2).			X			
4. End treatment installed, or "Clear zone" established. (S-630-2, Note 9).			X			
5. Correct Taper (RDG 9.2.1.2, 4:1 to 8:1, S-630-1, Sht 1, Note 17).			X			
D. Team Weighting						
Section Score (Sum X Wt)					27	27

Section VI Comments.

Nice Work.

VII. PAVEMENT MARKINGS (Wt. =2)	Yes	No	NA	NC	Score	Total Poss.
A. Pavement marking plan on file. (627.03).	X				2	2
B. Conflicting markings properly removed. (627.03(d), 202.05, MUTCD 6F.67).			X			
C. Pavement markings placed correctly (full compliance, width, length, location, waviness) (627.03) (per plans, specs, and MUTCD).	X				2	2
1. No passing zones in full compliance. (627.03).			X			
D. Satisfactory condition (not overly faded, damaged or obscured).	X				2	2
E. Team Weighting						
Section Score (Sum X Wt)					6	6

Section VII Comments.

Appendix B

VIII. MISCELLANEOUS ITEMS (Wt. = 3)	Yes	No	NA	NC	Score	Total Poss.
A. "Clear Zone" free of obstructions. (per plans or RDG 9.1.1).						
1. Construction materials/equipment out of clear zone or protected.	X				3	3
2. Hazards in clear zone (other than barrier) delineated or protected .	X				3	3
3. Pavement edge drop-offs minimized, marked if present (MUTCD 6F.44).	X				3	3
B. Impact attenuators:						
1. Installed per specifications (proper array and pad).			X			
2. Lids in place, dry sand, good condition.			X			
3. Other attenuator types installed properly and maintained.			X			
C. Pilot car operation correct. (630.14).			X			
D. Temporary Traffic Signals (614, 630.04).						
1. Timing adequate.			X			
2. Vertical clearance adequate/proper location of heads.			X			
E. Team Weighting						
Section Score (Sum X Wt)					9	9
Section VIII Comments.						

IX. TRAFFIC IMPACTS (Wt. = 2)	Yes	No	NA	NC	Score	Total Poss.
A. Adequate driver guidance (Drivers understand where to go).	X				2	2
B. Traffic delays being mitigated (Alt Rte, delays advertised etc.).	X				2	2
C. Accidents documented (630.11(5)(xi)).	X				2	2
D. Work Zone speed limit.						
1. Form 568 on file (CM, Appendix B).	X				2	2
2. Speed reduction appropriate for operation (not too slow/not too fast).	X				2	2
3. "Fines Doubled" and return to speed limit properly placed (S-630-1, Sht 11).	X				2	2
E. Team Weighting						
Section Score (Sum X Wt)					12	12
Section IX Comments.						

Appendix B

X. WORK ZONE AREA AND WORKER SAFETY (Wt. = 2)	Yes	No	NA	NC	Score	Total Poss.
A. Safe entrance/exit to work zone for equipment and workers (630.10(5)).	X				2	2
B. Work zone buffer adequate (MUTCD 6C.06).	X				2	2
C. Team Weighting						
Section Score (Sum X Wt)					4	4
Section X Comments.						

XI. UNIFORM TRAFFIC CONTROL (For Information Only) (Wt. = 2)	Yes	No	NA	NC	Score	Total Poss.
A. Current Training Card on File (Policy Memo 29).			X			
B. Proper Safety Vest (Class II or III).			X			
C. Team Weighting						
Section Score (Sum X Wt)					0	0
Section XI Comments.						

SUMMARY	Score	Total Poss.	Perc.
I. TRAFFIC CONTROL MANAGEMENT	7	8	88%
II. METHOD OF HANDLING TRAFFIC (MHT)	20	22	91%
III. WORKSITE TRAFFIC CONTROL SUPERVISOR (TCS)	6	6	100%
IV. FLAGGERS	6	7	86%
V. CONSTRUCTION/MAINTENANCE SIGNING	18	24	75%
VI. TRAFFIC CONTROL DEVICES	27	27	100%
VII. PAVEMENT MARKINGS	6	6	100%
VIII. MISCELLANEOUS ITEMS	9	9	100%
IX. TRAFFIC IMPACTS	12	12	100%
X. WORK ZONE AREA AND WORKER SAFETY	4	4	100%
XI. UNIFORM TRAFFIC CONTROL	0	0	--
Overall Score:	115	125	92%

Overall Comments:
 Nice Project thanks you for addressing issues immediately.

Project Final Submittal Checklist

The following is the Project Final Submittal Checklist. Refer to section 121.2.6 for details on how to use this document. An electronic version can be obtained from your Final Administrator.



Project Final
Submittal Checklist.

Project Final Submittal Checklist

Contract ID: _____

Project Number: _____

Reference: Section 121 of the *Construction Manual*

- | | Included | N/A | Needed |
|--|--------------------------|--------------------------|--------------------------|
| 1. Acceptance Letter - Timely submittal is EMPHASIZED . Itemize all documentation still outstanding from Contractor. Be specific. See <i>Construction Manual (CM)</i> 109.9.1 and 120.3.2 for distribution; Appendix B for example. | <input type="checkbox"/> | <input type="checkbox"/> | <input type="checkbox"/> |
| 2. CDOT Form 1212 (Final Acceptance Report). Required on <u>ALL</u> projects. RE will print form from SAP and submit to Region Finals office. | <input type="checkbox"/> | <input type="checkbox"/> | <input type="checkbox"/> |

Pay Documentation

- | | | | |
|---|--------------------------|--------------------------|--------------------------|
| 3. Engineering Personnel Roster. Must be complete with all project personnel names and initials. | <input type="checkbox"/> | <input type="checkbox"/> | <input type="checkbox"/> |
| 4. Books/Electronic files with CDOT Form 266/DWR's, CDOT Form 7's, and all original source documentation. | <input type="checkbox"/> | <input type="checkbox"/> | <input type="checkbox"/> |
| 5. Printed/Electronic copies of all Item Summary reports (305's), initialed by the PE/PM. | <input type="checkbox"/> | <input type="checkbox"/> | <input type="checkbox"/> |
| 6. Scale Checks and Scale/Weighers Certifications for all weighers, valid during material placement, including concrete scales. | <input type="checkbox"/> | <input type="checkbox"/> | <input type="checkbox"/> |
| 7. Asphalt & Concrete Scale tickets in envelopes, with totaled tapes or totaled spreadsheet and completed stamp on front of envelope. | <input type="checkbox"/> | <input type="checkbox"/> | <input type="checkbox"/> |
| 8. Haul vehicle ID sheets. (Used to check for overweight loads). | <input type="checkbox"/> | <input type="checkbox"/> | <input type="checkbox"/> |
| 9. Field Books (Piling, grade stakes, etc.). | <input type="checkbox"/> | <input type="checkbox"/> | <input type="checkbox"/> |
| 10. Survey documentation w/ Professional Land Surveyor stamp, signed Survey control data sheets and/or Monumentation records or previously submitted to ROW on _____. | <input type="checkbox"/> | <input type="checkbox"/> | <input type="checkbox"/> |
| 11. Force Account Billings. Please note if still outstanding from Contractor. | <input type="checkbox"/> | <input type="checkbox"/> | <input type="checkbox"/> |
| 12. All Change Orders w/Letters of Explanation & attachments that have not been previously submitted. | <input type="checkbox"/> | <input type="checkbox"/> | <input type="checkbox"/> |
| 13. Seeding Tickets w/PLS calculations if not submitted with material documentation. | <input type="checkbox"/> | <input type="checkbox"/> | <input type="checkbox"/> |
| 14. CDOT Form 105's (Speed Memo), that effect Contractor payments (i.e. work zone violations, deleted/unused items), if not already submitted. | <input type="checkbox"/> | <input type="checkbox"/> | <input type="checkbox"/> |
| 15. Signed copies of <u>First & Last</u> Form 262's/263's (Time Counts), if not already submitted. | <input type="checkbox"/> | <input type="checkbox"/> | <input type="checkbox"/> |

Water Quality

- | | | | |
|---|--------------------------|--------------------------|--------------------------|
| 16. Water Quality Notebook (inspection reports, memos, etc.) turned over to Water Quality Manager on _____. | <input type="checkbox"/> | <input type="checkbox"/> | <input type="checkbox"/> |
| 17. 404 Permit transferred to _____ on _____. | <input type="checkbox"/> | <input type="checkbox"/> | <input type="checkbox"/> |

Appendix B

	Included	N/A	Needed
<u>Civil Rights</u> - Send original forms to CRO. Keep Copy in project file.			
18. Checked Payrolls to Region Civil Rights office (all Federal Aid Projects and F/A work). (CM 107.1.1.2; 121.2.8). Payrolls submitted on _____.	<input type="checkbox"/>	<input type="checkbox"/>	<input type="checkbox"/>
19. OJT Documentation - copies of CDOT Form 832's, 838's, 1337 & 266/DWR showing payments. (Note: CDOT 832's should be submitted monthly to the CRO).	<input type="checkbox"/>	<input type="checkbox"/>	<input type="checkbox"/>
20. DBE Documentation - (CDOT Form 1419 should be submitted quarterly to the CRO).	<input type="checkbox"/>	<input type="checkbox"/>	<input type="checkbox"/>
21. Final CDOT Form 1419 with PE/PM and Prime Contractor signature. Required on all Projects. If subs were not used submit form with statement "none used".	<input type="checkbox"/>	<input type="checkbox"/>	<input type="checkbox"/>
22. Copies of CDOT Form 205 - Permit to Sublet (Should be submitted to the CRO when received for CRO approval).	<input type="checkbox"/>	<input type="checkbox"/>	<input type="checkbox"/>
23. Copies of CDOT Form 1418 - Monthly Payment Summary (payments to subcontractors) per §109.06e.	<input type="checkbox"/>	<input type="checkbox"/>	<input type="checkbox"/>
24. Copy of updated CDOT Form 1425 - Suppliers list. (§106 revised 1-30-14).	<input type="checkbox"/>	<input type="checkbox"/>	<input type="checkbox"/>
<u>Miscellaneous</u>			
25. "As Constructed" plans completed per CM 121.2.3.	<input type="checkbox"/>	<input type="checkbox"/>	<input type="checkbox"/>
26. Contractor Performance Evaluation Completed & Submitted on _____.	<input type="checkbox"/>	<input type="checkbox"/>	<input type="checkbox"/>
27. Buy America Certifications received and included in Inspector's Book(s).	<input type="checkbox"/>	<input type="checkbox"/>	<input type="checkbox"/>
28. CDOT Form 513 -RSAR (Roadway Surface Accomplishment Report) form completed online on _____ . Printed copy included. <u>Form</u> available at https://www.codot.gov/library/forms/fhwa-other-forms/rsar.pdf/view	<input type="checkbox"/>	<input type="checkbox"/>	<input type="checkbox"/>

Copy of this checklist with Final box to Region Finals Administrator

Date: _____

Submitted By: _____
(Name)

Clear Form

Final Materials Submittal Checklist

An example of the Final Materials Submittal Checklist is presented.



Final Materials
Submittal Checklist.

Final Materials Submittal Checklist

Contract ID: _____

Project Number: _____

Reference: Field Materials Manual for specification year of the project

	Included	N/A	Needed
1. CDOT's Application for Reporting (CAR) Final Materials Documentation and Checklist (Form 473). With page 2-Letter of Exceptions with attachments.	<input type="checkbox"/>	<input type="checkbox"/>	<input type="checkbox"/>
2. CAR Owner Acceptance Sampling Checklist (Form 250). Signed.	<input type="checkbox"/>	<input type="checkbox"/>	<input type="checkbox"/>
3. CAR Certification Checklist.	<input type="checkbox"/>	<input type="checkbox"/>	<input type="checkbox"/>
4. CAR Project Independent Assurance Sampling Checklist w/supporting documentation (Form 379).	<input type="checkbox"/>	<input type="checkbox"/>	<input type="checkbox"/>
5. CAR Incentive/Disincentive Report. (Asphalt, Voids, or Concrete 03). (Signed Final Report).	<input type="checkbox"/>	<input type="checkbox"/>	<input type="checkbox"/>
6. Other Price Reductions.	<input type="checkbox"/>	<input type="checkbox"/>	<input type="checkbox"/>
7. Random Sample Schedule.	<input type="checkbox"/>	<input type="checkbox"/>	<input type="checkbox"/>
8. CDOT Form 1324 (Evaluation of Materials Testing) per CP 16.	<input type="checkbox"/>	<input type="checkbox"/>	<input type="checkbox"/>
9. PC Data (Contractor's Notebook(s)).	<input type="checkbox"/>	<input type="checkbox"/>	<input type="checkbox"/>
10. OA Data (Notebook(s) containing Field Materials Work Sheets).	<input type="checkbox"/>	<input type="checkbox"/>	<input type="checkbox"/>
11. Hazardous Material Certification (§106.02b).	<input type="checkbox"/>	<input type="checkbox"/>	<input type="checkbox"/>

Copy of this checklist with Final to Region Materials Documentation Coordinator

Date: _____

Submitted By: _____
(Name)

Clear Form

CPM Schedule Review Checklists

Use these checklists to assist in reviewing project CPM schedules.

Checklist 1 - Schedule Submittal checklist will help ensure that a schedule submittal is complete. The best response to each item in the checklist is “yes”.

Checklist 2 - Preliminary and Baseline Schedule checklist will help determine topics for the Schedule Review meeting and the items the Contractor needs to address. It is possible that not all of the items listed apply to every project. The best response to each item in the checklist is “yes”. If a statement applies and you cannot answer yes, decide if you should respond approve or require corrections and resubmit.

Checklist 3 - Project Schedule Update checklist will help determine topics for the Schedule Review meeting and the items the Contractor needs to address. It is possible that not all of the items listed apply to every project. The best response to each item in the checklist is “yes”. If statement applies, and you cannot answer “yes,” decide if you should respond Approve-as-noted, require corrections and resubmit, or require a Revised Schedule.

Checklist 4 - Revise and Resubmit Schedule checklist lists issues that require revision of the Schedule. When these items are answered “yes,” consider requiring corrections (respond with Approve-as-Noted) and requiring the contractor to resubmit the submittal.

Checklist 5 - Schedule Risk Analysis checklist offers points to consider when analyzing schedule risk and help determine if a schedule consultant is needed.



CPM Schedule
Review Checklists.pdf

**CPM Schedule Review Checklist
1 - Schedule Submittal**

Project Number: _____ Project Code: _____

Schedule Reviewed: _____
e.g., Baseline Rev 1, Jan 19 Update, Update 5

Reviewed By: _____ Date: _____

<p>The schedule submittal includes the electronic schedule files in the native file format. (*.mpp for Microsoft Project schedules or *.xer for Primavera schedules)</p>	
<p>Subsequent submittals are the same native file format as the first submittal. The scheduling software shall not change after the first schedule submittal.</p>	
<p>The schedule submittal is appropriately labeled per 108.03, including filenames, schedule type, CDOT project number, subaccount, project name, Contractor name, data date, submittal date, if applicable, revision number and date.</p>	
<p>The submittal package includes all reports and activity block information listed in 108.03.</p> <ul style="list-style-type: none"> • PDF of the time-scaled logic diagram • Job Progress Narrative report • Predecessor Activity and Successor Activity report • Early Start report sorted by actual and early start dates • Float report in ascending order of available float • Critical Path report • Non-work day list 	
<p>The PDF of the time-scale logic diagram includes a clear picture of the Critical Path beginning with the project start date or data date.</p>	

Appendix B

**CPM Schedule Review Checklist
2 - Preliminary and Baseline Schedule**

Project Number: _____ Project Code: _____

Schedule Reviewed: _____
e.g., Baseline Rev 1, Jan 19 Update, Update 5

Reviewed By: _____ Date: _____

Response: _____ Date: _____

1	The Job Progress Narrative make sense and clearly addresses issues.	
2	The narrative, schedule and reports complement each other and there are no conflicts between them.	
3	The Preliminary or Baseline Schedule show completion of all work within contract time.	
4	No progress is shown on the Preliminary or Baseline Schedule.	
5	The schedule sufficiently detailed to make it useful. For Preliminary Schedules, focus on the first 60 days.	
6	All subcontracted work is included and the responsible parties identified for each activity.	
7	Time is allowed for setup and mobilization, and acquiring any special equipment.	
8	The schedule includes lead time to obtain necessary permits and any permit restrictions. The schedule address environmental commitments (i.e., migratory bird restrictions).	
9	The schedule includes the third party work, such as ROW acquisitions, railroad restrictions, or utility relocation.	
10	The important or long-lead procurement, fabrication, and delivery times are included and the durations are reasonable.	
11	Adequate time or the contractually required review times are included for development and review of submittals, working drawings, and shop drawing preparation.	
12	The schedule includes downtime for curing, between successive paving courses or concrete placements, or for embankment settlement.	

**CPM Schedule Review Checklist
2 - Preliminary and Baseline Schedule**

13	Contractual milestones and constraints are included. Milestones for project start and end dates and phasing start and end dates are included.	
14	The list of non-work days and schedule address public events, local celebrations, holidays, weather, weekends, and other work restrictions. The schedule reflects restrictions for nighttime and weekend operations.	
15	The schedule shows work performed during appropriate seasons. If the schedule shows work such as concrete placement in cold weather, discuss with the Contractor on its plan to address seasonal conditions.	
16	The workflow or order of work appears logical. The critical path and near critical path make sense. If there are there multiple critical paths, have additional discussions in the Schedule Review meeting.	
17	The relationships make sense and all activities are tied together logically. (i.e., FS, SS, or FF, approved lags and approved constraints)	
18	All activities have both a predecessor (except the first one) and a successor (except the last one). No activities have only a SS as only a predecessor or FF as only successor.	
19	No activities have a duration greater than 15 days. Durations are limited to 15 calendar days unless approved. A construction duration for embankment or paving should be broken out into activities of 15 days or less by location, stations, or work area. A duration for a long-lead item delivery or certain submittals and reviews could be greater than 15 days.	
20	Durations and production rates are reasonable. Production rates for critical and near critical activities agree with the narrative.	
21	There are no lags nor lags in excess of 10 days in the schedule. If so, a reasonable explanation is included. Lags longer than 10 days require Engineer approval and Negative lags (leads) are not allowed.	
22	There are no constraints in the schedule. If so, the explanation for the constraint is reasonable and the Engineer approved the constraint.	
23	The effect of traffic and phasing on production rates and the sequence of operations is taken into account	
24	Potential conflicts with adjacent projects, both public and or private are addressed or accounted for.	

**CPM Schedule Review Checklist
3 - Project Schedule Update**

Project Number: _____ Project Code: _____

Schedule Reviewed: _____
e.g., Jan 19 Update, Update 5 Rev3

Reviewed By: _____ Date: _____

Response: _____ Date: _____

1	All required corrective actions from the previous submittal are addressed.	
2	The narrative, schedule, reports, and Weekly Planning Schedule complement each other and there are no conflicts between them.	
3	Actual progress is recorded accurately and the actual start dates, actual finish dates, and actual durations reflect what occurred. The schedule reflects all work that occurred. All completed activities are shown appropriately. The schedule does not show progress on items where no work occurred. Discuss the discrepancies with the contractor and resolve the discrepancies before approving the schedule. This is not optional.	
4	For any activity in progress (an activity that has an actual start date and no actual finish date) the remaining duration is accurate.	
5	There are no activities with an actual start date and showing no progress. This can be an indicator of a suspended activity or an activity with lower production than the planned production. Evaluate these activities closely by looking at the Original Duration vs. Remaining Duration. They should not have changed.	
6	No actual start dates, actual finish dates, or actual durations that were reported in previous updates, have been changed. No such changes should occur. The only exception is a correction to inaccurately reported dates or durations. This is not optional.	
7	There are no added modified or deleted activity descriptions, activity IDs, relationships, lags, or constraints. If there are, the Contractor's narrative or explanation adequately address the need for each change.	
8	There are no "orphaned" activities and all activities are logically tied together.	
9	All constraints and lags are approved by the Engineer.	
10	There are no delays or unplanned events shown in the schedule. If so, the Contractor's Job Progress Narrative adequately addresses the delays or unplanned events.	

**CPM Schedule Review Checklist
3 - Project Schedule Update**

11	The schedule is in compliance with contract requirements and milestone dates.	
12	All actual dates occurred before the data date. The schedule shows actual progress up to the data date. The schedule does not show actual progress occurring after the data date. If this is the case, it does not impact the critical path. 'Approved as noted' If it does impact the critical path, discuss this with the contractor.	
13	There are no dates entered nor progress shown for a suspended or resumed activity.	
14	The early finish dates for incomplete work do not occur before the data date.	
15	There are no activities started or been performed out-of-sequence. If so, the Contractor's Job Progress Narrative adequately addresses the reasoning for this.	
16	Compare progress on the critical path to the previous schedule update. The critical path did not change since last update. If so, the Job Progress Narrative adequately addresses the reasoning.	
17	The project completion date did not slip or improve since last update. The Job Progress Narrative adequately addresses the change.	

**CPM Schedule Review Checklist
4 - Revise and Resubmit**

Project Number: _____ Project Code: _____

Schedule Reviewed: _____
e.g., Jan 19 Update, Update 5 Rev3

Reviewed By: _____ Date: _____

Response: _____ Date: _____

The submittal is incomplete.	
Schedule is missing significant work items, submittals, permits, CDOT review periods, etc.	
Durations to accomplish work seem grossly inadequate.	
Baseline Schedule or Preliminary Schedule show completion after contract time.	
The schedule includes and start to finish relationship, and/or includes lags, or constraints that are not approved by the Engineer.	
There are activities with no predecessor and successor, or only have a start-to-start as a predecessor or finish-to-finish as a successor.	
The schedules does not address contract milestones, restrictions, or no-work periods.	
The Project Schedule Update or resubmitted schedule fails to address the Engineer's comments in a satisfactory manner.	

**CPM Schedule Review Checklist
5 - Schedule Risk Analysis**

Project Number: _____ Project Code: _____

Reviewed By: _____ Date: _____

Decision: _____ Date: _____

Risk Level	High	Medium	Low
Alternative Delivery method or tool utilized (Design-Build, A+B, Completion Incentives or Disincentives, Lane Rentals, etc.)	DB and/or 1 or more item applies	1 item applies	None
Project Cost	≥\$40 million	≥\$10 million	<\$10 million
Likelihood of political implications related to time	High	Medium	Low
Project has critical milestones or weather and environmental concerns	Yes	Minor	None
Risk of extending work into winter or a second construction season	Unwanted	Not preferred	Not an issue
Likelihood of potential third party delays (Utilities, Railroads, or other projects)	High	Medium	Low
Changes under ad, or last minute changes in the scope	Major changes	Minor changes	No changes
Contractor is experienced in developing CPM Schedules	No or unknown		Yes
Contractor's history for completing work in Contract time and history in requesting time extensions	Often delayed or requests time	Good - few requests	Good -no requests
Contractor's history of filing disputes and claims	Often	Sometimes	None to rarely
Scheduling Software	Primavera		Microsoft Project
CDOT Project staff is experienced in evaluating CPM Schedules and attended CPM Schedule Training	Neither	Some	Yes
Comments:			

CDOT CONSTRUCTION MANUAL

APPENDIX C. CHANGE ORDER EXAMPLES

Appendix C

APPENDIX C. CHANGE ORDER EXAMPLES	C-1
CHANGE ORDER EXAMPLES	C-3

CHANGE ORDER EXAMPLES

Appendix C presents examples of the most common types of change orders that Project Engineers and Project Inspectors will prepare on a day-to-day basis. Although either the Project Engineer or the Project Inspector may prepare the change order, the Project Engineer is responsible for ensuring it is properly approved and distributed.

A sample Letter of Explanation accompanies each example change order. See Appendix B for guidance on preparing other letters and forms (e.g., Form 266).

Form 90 - Contract Modification Order is available at Forms Management on the Intranet Web Site. Consultants may obtain the forms from their CDOT contact.

Major CMO (Earthwork)

MEMORANDUM

DEPARTMENT OF TRANSPORTATION

4201 E. Arkansas Avenue
 Denver, Colorado 80222
 Phone 303-757-9011



DATE: July 7, 2013 Re: 19999/NH 66-066
SH 66-South

TO: (Resident Engineer or Program Engineer as per Region requirements)

FROM: (Project Engineer)

SUBJECT: Contract Modification Order #3, Sight Distance Improvements

This change order was written to compensate the Contractor for sight distance improvements at SH 66 and County Road 9. This intersection is the site of several recent accidents attributed to limited sight distance. The accident history did not warrant these improvements in the design phase of this overlay project. However, Jim Nelemb, Region Traffic Engineer, has requested this modification, at the urging of the local City Mayor and Fire Department.

The improvements include excavation of a cut slope between Station 239+ and Station 243+ right on SH 66, which limits sight distance to 150 feet for eastbound County Road 9 traffic. After excavation, the sight distance will be 500 feet as indicated on the attached drawing and as requested by the Region Traffic Engineer. The work will also include Topsoil, Seeding (Native), and Mulching (Weed Free), in order to revegetate the slope. The seed mix was provided by Mike Banoman, Staff Landscape Architect.

Item 203-00010, Unclassified Excavation (CIP), will be paid at the negotiated unit price of \$8.50/cubic yard for approximately 2000 cubic yards. This is within 3% of the 2012 *Cost Data Book* yearly average awarded price of \$8.37/cubic yard.

Item 207-00205, Topsoil, will be paid at the negotiated unit price of \$29.00/cubic yard for approximately 100 cubic yards. This price is within 5% of the weighted average awarded price of \$27.65/cubic yard for projects with similar quantities (+/- 50 cubic yards) from the 2012 *Cost Data Book*. The weighted average calculation is shown below for the projects with similar quantities:

	Qty (CY)	Unit Price (\$/CY)	Total (\$)
BR157A-011	109	34.00	3,706.00
CO701-217	100	21.00	2,100.00
FBR066A-002	64	21.00	1,344.00
SHE0701-215	120	31.00	3,720.00
Total	393		10,870.00

Weighted average price is \$10,870.00/393 CY = \$27.65/cubic yard

Item 212-00003, Mulching (Weed Free Hay) will be paid at the negotiated unit price of \$550.00/acre for approximately 1 acre. This is reasonable when compared to the average yearly price of \$577.97 /acre from the 2012 *Cost Data Book*.

Item 212-00006, Seeding (Native), will be paid at the negotiated unit price of \$1,300.00/acre for approximately 1.00 acre. This is reasonable when compared to the independent cost analysis (force account analysis) of \$1,333.94/acre shown below:

Appendix C

July 7, 2013
 NH 66-066
 Page 2

Labor: (Davis Bacon rates include fringes)			
Foreman	\$35.00/hr x 4 hours	\$140.00	
Operator	\$29.00/hr x 4 hours	116.00	
Laborer	\$22.00/hr x 4 hours	<u>88.00</u>	
Labor Subtotal		\$344.00	
	+67% loading	<u>230.48</u>	
Labor Total		\$ 574.48	\$ 574.48
Equipment: (Rates from 2012 QCTM, Ch. 6 Historical Data)			
Pick up	\$23.15/hr. x 4 hours	\$ 92.60	
Trailer mounted seed sprayer	\$19.45/hr x 4 hours	77.80	
Flatbed Truck	\$33.23/hr. x 4 hours	<u>132.92</u>	
Equipment Total		\$303.32	\$ 303.32
Material: (From attached supplier quote to contractor)			
Seed for 1 acre		\$300.00	
	+15% loading	<u>45.00</u>	
Material Total		\$345.00	\$ 345.00
Sub -Total Cost			\$1,222.80
Admin. loading (109.04(e)) on subcontract work	\$100 + .05(222.80)		<u>111.14</u>
TOTAL			\$1,333.94

The Contractor has requested no additional mobilization for this work. The total cost of this change order is \$21,750.00

The projected cost for this project including this change order is \$1,440,000.00 or 1.7 percent under the current allotment as shown on the attached Form 65, Project Financial Statement. No budget action is required. The budget summary is as follows:

Current Project Budget	\$1,500,000.00	
Projected Costs to Completion	<u>\$1,475,000.00</u>	
Projected Surplus (Deficit)	\$25,000.00	(1.7%)

The added work will be performed concurrently with other items, therefore no additional time is required. The Contractor has been directed by Form 105 to proceed with this work. A copy of the completed Form 105 is attached.

This change order was discussed with the Jim LaFuz, Contracts and Market Analysis Area Engineer on July 4, 2013. Concurrence was obtained from Don Shotsat, Project Manager and John Cheney, Region Program Engineer on July 2, 2013. This change order was discussed with Bert Miles, FHWA Operations Engineer on July 4, 2013 and he determined he did not need to sign the Form 90.

LTR-Change to Scope or Intent of Contract

Appendix C

Major CMO (Earthwork)

COLORADO DEPARTMENT OF TRANSPORTATION CONTRACT MODIFICATION ORDER		Project No.: NH 66-066	Project Code (SA#): 19999																																																															
		Location: SH 66 South																																																																
		Date: July 7, 2013	Project Order No.: 003																																																															
Contractor: Good Aim Construction		Estimated cost to project: <input checked="" type="checkbox"/> Increase <input type="checkbox"/> Decrease \$21,750.00																																																																
Complete Address: 14555 Lost Road Aurora, CO 80011		Total additional days allowed to complete work: 0	Federal Oversight? <input checked="" type="checkbox"/> Yes <input type="checkbox"/> No																																																															
Modification Title: Sight Distance Improvements																																																																		
<p>Your Contract is hereby modified to include sight distance improvements for the intersection with County Road 9 between Station 239 and Station 244 on SH 66 as shown on attached revised plan sheet 156X. The work will include excavation of a cut slope between Station 239+ and Station 243+ right, Topsoil, Mulching (Weed Free Hay), and Seeding (Native) in order to revegetate the slope. The work will be completed in accordance with the 2011 CDOT Standard Specifications for Road and Bridge Construction, all contract documents, the attached seed mix, and as directed by the Engineer.</p> <p>The following items are hereby added to your contract at agreed unit prices:</p> <table border="1" style="width: 100%; border-collapse: collapse;"> <thead> <tr> <th>Project</th> <th>Catg</th> <th>Line</th> <th>Item No.</th> <th>Description</th> <th>Quantity</th> <th>Unit</th> <th>Unit Price</th> <th>Total</th> </tr> </thead> <tbody> <tr> <td>19999-BID 0200</td> <td>0605</td> <td>203-00010</td> <td></td> <td>Unclassified Excavation CMO 3</td> <td>2,000.000</td> <td>CY</td> <td>\$8.50</td> <td>\$17,000.00</td> </tr> <tr> <td>19999-BID 0200</td> <td>0610</td> <td>207-00205</td> <td></td> <td>Topsoil CMO 3</td> <td>100.000</td> <td>CY</td> <td>\$29.00</td> <td>\$2,900.00</td> </tr> <tr> <td>19999-BID 0200</td> <td>0615</td> <td>212-20003</td> <td></td> <td>Mulching (Weed Free Hay) CMO 3</td> <td>1.000</td> <td>Acre</td> <td>\$550.00</td> <td>\$550.00</td> </tr> <tr> <td>19999-BID 0200</td> <td>0620</td> <td>212-20006</td> <td></td> <td>Seeding (Native) CMO 3</td> <td>1.000</td> <td>Acre</td> <td>\$1,300.00</td> <td>\$1,300.00</td> </tr> <tr> <td colspan="8">Total added items:</td> <td>\$21,750.00</td> </tr> <tr> <td colspan="8">Total for Contract Modification Order 003:</td> <td>\$21,750.00</td> </tr> </tbody> </table> <p>This order does not change your contract completion date.</p>				Project	Catg	Line	Item No.	Description	Quantity	Unit	Unit Price	Total	19999-BID 0200	0605	203-00010		Unclassified Excavation CMO 3	2,000.000	CY	\$8.50	\$17,000.00	19999-BID 0200	0610	207-00205		Topsoil CMO 3	100.000	CY	\$29.00	\$2,900.00	19999-BID 0200	0615	212-20003		Mulching (Weed Free Hay) CMO 3	1.000	Acre	\$550.00	\$550.00	19999-BID 0200	0620	212-20006		Seeding (Native) CMO 3	1.000	Acre	\$1,300.00	\$1,300.00	Total added items:								\$21,750.00	Total for Contract Modification Order 003:								\$21,750.00
Project	Catg	Line	Item No.	Description	Quantity	Unit	Unit Price	Total																																																										
19999-BID 0200	0605	203-00010		Unclassified Excavation CMO 3	2,000.000	CY	\$8.50	\$17,000.00																																																										
19999-BID 0200	0610	207-00205		Topsoil CMO 3	100.000	CY	\$29.00	\$2,900.00																																																										
19999-BID 0200	0615	212-20003		Mulching (Weed Free Hay) CMO 3	1.000	Acre	\$550.00	\$550.00																																																										
19999-BID 0200	0620	212-20006		Seeding (Native) CMO 3	1.000	Acre	\$1,300.00	\$1,300.00																																																										
Total added items:								\$21,750.00																																																										
Total for Contract Modification Order 003:								\$21,750.00																																																										
The Contractor accepts this change order for work to be performed and prices on which payment is to be based.																																																																		
REQUIRED IN ACCORDANCE WITH INSTRUCTIONS IN THE CDOT CONSTRUCTION MANUAL		REQUIRED FOR ALL CHANGE ORDERS																																																																
Approved by FHWA Operations Engineer:	Date:	Authorized by Project Engineer:	Date:																																																															
OPTIONAL		Contractor Representative:	Date:																																																															
Approved by Region Transportation Director:	Date:	Approved by Resident Engineer:	Date:																																																															
		<input type="checkbox"/> Participating <input type="checkbox"/> Non-participating <input type="checkbox"/> Participation as noted																																																																
		Approved Funding by Region Program Engineer:	Date:																																																															

CDOT Form 90 07/02

Project Termini Extension Type I (Erosion Control)

MEMORANDUM

DEPARTMENT OF TRANSPORTATION

4201 E. Arkansas Avenue
Denver, Colorado 80222
Phone 303-757-9011



DATE: June 30, 2013 RE: 11111/NH 66-066
Route 66-South

TO: (Resident Engineer or Program Engineer as per Region requirements)

FROM: (Project Engineer)

SUBJECT: Contract Modification Order #2, Project Extension Type I, Erosion Control

This change order was prepared to correct erosion problems on the previous Route 66 corridor project. These problems consist of ditch scour, plugged and washed out culverts, slope erosion, undermined pavement, and increased flows directed into an offsite drainage. These problems were created by inadequate design of the drainage features.

The work will consist of grading, seeding, mulching, soil retention blanket, erosion bales, S&D Paving (Asphalt), inlets, check dams, and rip rap in selected ditches where steep grades and excessive flows have contributed to ditch scour. Additional work includes cleaning of selected culverts, relaying of a washed out culvert, placing of topsoil, grading eroded slopes, seeding and soil retention blanket on steep erodible fill slopes, and placing two 24-inch culverts on North Chicken Creek Road to direct increased offsite flows out of an undersized ditch. Grading of the ditches and slopes will be performed with Blading, Dozing and Combination Loader hours.

All bid items affected by this change order will be paid at the Contract bid unit prices. Soil Retention Blanket will be paid at the negotiated bid unit price of \$2.00/square yard for approximately 2000 square yards. This is reasonable when compared to the average bid price of \$2.10/square yard from the *2000 Cost Data Book*. Relaying of pipe will be paid at the negotiated unit price of \$40.00/linear foot for 90 linear feet. This is reasonable when compared to the average bid price of \$39.50/linear foot from the *2000 Cost Data Book*. Clean culvert will be paid at the negotiated unit price of \$200.00/each for approximately 5 culverts. This is reasonable when compared to the average bid price of \$197.00/each from the *2000 Cost Data Book*.

In accordance with the *CDOT Construction Manual* the following criteria has been met:

- The Contractor is willing to perform this extra work.
- The need for this work was initially established but was not included in the plans due to budget constraints.
- The work constitutes a lengthening of this project and is similar in kind and nature to the original Contract.
- Project funds are available and the work can be completed at reasonable prices.
- The added work will be performed at Contract unit prices or negotiated unit prices.
- The total value of the extra work is less than \$100,000.00.
- The value of negotiated work does not exceed 20 percent of the value of the added work.
- Preapproval has been obtained from FHWA.

This work will be performed concurrently with other activities and will not require additional time.

The projected cost for this project including this change order is \$11,668,241.27 or 0.1 percent under the current allotment as shown on the attached Project Financial Statement. The budget summary is as follows:

Appendix C

June 30, 2013
11111/NH 66-066
Page 2

Current Project Allotment	\$	11,656,459.00	
Projected Costs to Completion	\$	11,668,241.27	
Projected Surplus (Deficit)	\$	(11,782.27)	-0.10%

This change order was discussed with Rock Hirschfeld, Region Program Engineer on June 23, 2001, and with Stone Jensen, Project Development Area Engineer on June 23, 2001. Concurrence was obtained from Don Shotsat, Project Manager on June 23, 2001, and from Rachel Carson, Region Planning and Environmental Manager on June 23, 2001. Written preapprovals from Gene Overseer, Chief Engineer, Dan Von Der Wagon, Project Development Branch Manager, and from Raoul Jesus of FHWA are attached.

A budget action will not be required for this change order.

In order not to delay the project, the Contractor has been directed by Form 105 to begin this work. A copy of the completed Form 105 is attached.

I Concur: _____
Project Development Branch Manager

I Concur: _____
Chief Engineer

Appendix C

Project Termini Extension Type I (Erosion Control)

COLORADO DEPARTMENT OF TRANSPORTATION CONTRACT MODIFICATION ORDER	Project No.: NH 66-066	Project Code (SA#): 11111
	Location: Route 66-South	
	Date: June 30, 2013	Project Order No.: 2
Contractor: Good Aim Construction	Estimated cost to project: <input checked="" type="checkbox"/> Increase <input type="checkbox"/> Decrease \$68,710.00	
Complete Address: 14555 Lost Road Aurora, Co. 80011	Total additional days allowed to complete work: 0	Federal Oversight? <input checked="" type="checkbox"/> Yes <input type="checkbox"/> No
Modification Title: Project Extension Type I, Erosion Control		

Your Contract is hereby modified to include erosion control work between Milepost 243.5 and Milepost 245.6 on Route 66. No additional time will be allowed for this work. The work will be completed in accordance with the Contract Specifications and as directed.

ITEM DESCRIPTION	UNIT	PREVIOUS QUANTITY	ADDED QUANTITY	REV. PLAN QUANTITY	UNIT PRICE	INCR. COST TO PROJECT
<u>INCREASE:</u>						
203 Blading	HR	100	40	140	\$81.00	\$3,240.00
203 Combination Loader	HR	350	40	390	\$65.00	\$2,600.00
203 Backhoe	HR	350	40	390	\$123.00	\$4,920.00
203 Dozing (Landscaping)	HR	200	40	240	\$84.00	\$3,360.00
206 Structure Excavation	CY	7549	50	7599	\$5.00	\$250.00
206 Structure Backfill	CY	2148	50	2198	\$14.00	\$700.00
207 Topsoil	CY	21658	500	22158	\$3.00	\$1,500.00
208 Erosion Bales	EA	2500	200	2700	\$10.00	\$2,000.00
208 Check Dam	EA	50	10	60	\$800.00	\$8,000.00
212 Seeding (Native)	ACRE	30	3	33	\$325.00	\$975.00
212 Seeding (Native) (Hydr.)	ACRE	10	2	12	\$540.00	\$1,080.00
212 Mulching (Weed Free)	ACRE	34	3	37	\$470.00	\$1,410.00
212 Mulch Tackifier	LB	6800	300	7100	\$1.95	\$585.00
216 Soil Retention Blanket	SY	4840	2000	6840	\$2.30	\$4,600.00
506 Rip Rap (12 inch)	CY	141	75	216	\$34.00	\$2,550.00
507 Bit S & D Paving (Asphalt)	TON	4.5	15	19.5	\$216.00	\$3,240.00
604 Inlet Type C (10 foot)	EA	2	2	4	\$2,400.00	\$4,800.00
617 24-inch Culvert Pipe	LF	1964	290	2254	\$35.00	\$10,150.00
630 Flagging	HR	20000	300	20300	\$22.50	\$6,750.00
<u>ADD:</u>						
210 Relay Pipe (30 inch)	FA	0	6000	6000	\$1.00	\$6,000.00
TOTAL ESTIMATED INCREASED COST TO PROJECT						\$68,710.00

The Contractor accepts this change order for work to be performed and prices on which payment is to be based.			
REQUIRED IN ACCORDANCE WITH INSTRUCTIONS IN THE CDOT CONSTRUCTION MANUAL		REQUIRED FOR ALL CHANGE ORDERS	
Approved by FHWA Operations Engineer:	Date:	Authorized by Project Engineer:	Date:
OPTIONAL		Contractor Representative:	Date:
Approved by Region Transportation Director:	Date:	Approved by Resident Engineer:	Date:
		<input type="checkbox"/> Participating <input type="checkbox"/> Non-participating <input type="checkbox"/> Participation as noted	
		Approved Funding by Region Program Engineer:	Date:

CDOT Form 90 07/02

Project Termini Extension Type II (Paving Plus Time)

MEMORANDUM

DEPARTMENT OF TRANSPORTATION
Region Four
Loveland Residency
2207 E. Hwy 402
Loveland, CO 80537
(970) 622-1270
FAX (970) 669-0289



DATE: 03/23/2012
TO: Laura Zamora, Region 4 Area Engineer
FROM: Gray Currier, Project Engineer
SUBJECT: Request for Pre-Approval, Extension of Project IM 392A-012, PIN 16639

Region 4 respectfully requests permission to extend the limits of Project IM 392A-012 a distance of 450 feet east on SH 392, in order to remove the currently deteriorated asphalt-pavement approach-to-project, and replace it with a concrete-pavement approach-to-project. Upon approval, a change order to place the 450-foot extension will be added to the current construction contract. Region 4 considers this a Type II – Critical Project Terminus Extension.

As required by Construction Manual paragraph 120.7.7.3.2, the following information is provided:

- The Contractor, Edward Kraemer & Sons, is willing to do the extra work. They have agreed to construct the additional quantities at original bid prices, and to construct added items at Cost Data Book weighted-average awarded bid prices. They will not require an additional mobilization payment.
- The Contractor has agreed to obtain sufficient additional bonding and insurance for the additional work, upon presentation of the Change Order.
- The proposed work is in close proximity to the project. The work is immediately adjacent to the current project, and will simply continue the paving on SH 392 an additional 450 feet to the east.
- The need for the work is of a critical nature for reasons of safety, structural adequacy, and design deficiency. The work will replace a rutted, unsafe portion of asphalt pavement; the existing asphalt roadway is structurally inadequate to handle the pre-intersection braking and turning movements of the projected traffic volumes; and the need for the added work is due to the deficiency of the original consultant-supplied project design, which did not address the poor condition of the existing approach-to-project.
- Sufficient funds exist in the current project to cover the proposed extension.
- The cost of the proposed work is not expected to exceed 50 percent of the value of the original Contract. Rather, the proposed work, at approximately \$325,000, will be only approximately 2 percent of the original Contract value of \$17,523,127.88.
- Contracts and Market Analysis Branch concurs that the anticipated cost saving to complete the work as a project extension is reasonable (Encl. 1).
- Performing the proposed work as a project extension will avoid the cost of preparing plans, advertising, and awarding a separate Contract. The cost as a separate project would be approximately \$396,000 (Encl. 2). As a project extension, the cost of approximately \$325,000 will save approximately 22 percent.

03/23/2012
Request for Extension Pre-Approval, 16639
Page 2 of 2

- Loveland Resident Engineer Scott Ellis and North Program Engineer Corey Stewart have concurred with the proposed design and the critical nature of the proposed extension.
- RPEM Myron Hora has completed the necessary environmental clearances and permits and has given written concurrence (Encl. 3).

Project IM 392A-012 is an FHWA full-oversight project. Written pre-approval has been provided by the FHWA Operations Engineer for use of Federal funds for this project extension (Encl. 4).

Region 4 respectfully requests permission to extend the limits of Project IM 392A-012 a distance of 450 feet east on SH 392.

I concur:

Project Development Branch Manager

3/26/12
(Date)

I concur:

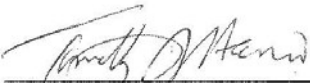
Chief Engineer

3/27/12
(Date)

Enclosures:

1. Memo, 03/13/12, Contract & Market Analysis Branch: Concurrence that anticipated cost saving as a project extension is reasonable.
2. Spreadsheet, 03/13/12, Cost savings as project extension vs as a separate project: approx 22%.
3. Environmental Clearances and Permits: CDOT Form 128a Categorical Exclusion Determination (Revision Date 03/20/12), with attached Form 463 (Revision Date 03/20/12).
4. Email, 03/20/12, FHWA Operations Engineer: Concurrence to use Federal funds for extension.

cc: Corey Stewart, Myron Hora, Scott Ellis, Greg Jones

MEMORANDUM

DEPARTMENT OF TRANSPORTATION
Contracts and Market Analysis Branch
4201 East Arkansas Avenue, 4th Floor
Denver, Colorado 80222
Telephone: (303) 757-9736
Facsimile: (303) 757-9868



DATE: 03/13/2012

TO: Gray Currier, Project Engineer

FROM: *Greg Jones, Contracts and Market Analysis Branch*

SUBJECT: Anticipated Cost Savings, Extension of Project IM 392A-012

I have compared the proposed costs of the project extension to the estimated costs if the work were bid as a separate contract. I have made adjustments to the estimated costs where appropriate. Please see the attached spreadsheet for the cost comparison.

I concur that the anticipated cost saving to complete the work as a project extension is reasonable.

Gregory S. Jones, PE
Engineering Estimates and Market Analysis Unit

1 Attachment:
Spreadsheet: 16639 Extension Estimate, 03-13-12

ENCL #1

Project Number: IM 392A-012 PCN: 16639 I-25 & SH 392 Interchange Reconstruction Cost Estimate as Project Extension										Estimated Prices and Costs for Separately Advertised and Awarded Project		
Line #	Category #	Item #	Description	Units	Quantity	Awarded Price	Total	EEMA*1 Unit Cost	Extended Cost			
40	200	202-00220	Removal of Asphalt Mat	SY	4,350	\$ 3.05	\$ 13,267.50	\$3.10	\$13,485.00			
50	200	202-00250	Removal of Pavement Marking	SF	500	\$ 0.91	\$ 455.00	\$1.00	\$500.00			
110	200	203-00060	Embankment Material (Complete in Place)	CY	4,350	\$ 4.83	\$ 21,010.50	\$6.44	\$28,014.00			
115	200	203-00062	Embankment Material (Complete in Place) (Special)	CY	4,350	\$ 5.59	\$ 24,316.50	\$8.50	\$36,975.00			
130	200	203-01100	Proof Rolling	HR	10	\$ 81.27	\$ 812.70	\$85.00	\$850.00			
150	200	203-01500	Blading	HR	10	\$ 86.35	\$ 863.50	\$103.00	\$1,030.00			
175	200	207-00205	Potholing	HR	35	\$ 165.94	\$ 5,807.90	\$198.00	\$6,930.00			
185	200	208-00002	Erosion Log (12 inch)	CY	300	\$ 3.56	\$ 1,068.00	\$5.42	\$1,626.00			
190	200	208-00020	Silt Fence	LF	200	\$ 5.08	\$ 1,016.00	\$4.56	\$912.00			
195	200	208-00034	Gravel Bag	LF	900	\$ 0.98	\$ 882.00	\$1.23	\$1,107.00			
200	200	208-00045	Concrete Washout Structure	Ea	3	\$ 1,036.81	\$ 3,110.43	\$978.00	\$2,934.00			
220	200	208-00206	Erosion Control Supervisor	Day	24	\$ 25.00	\$ 600.00	\$85.00	\$2,040.00			
230	200	210-00810	Reset Ground Sign	Ea	3	\$ 60.34	\$ 181.02	\$65.00	\$195.00			
240	200	210-00831	Reset Traffic Signal Head	Ea	4	\$ 135.77	\$ 543.08	\$142.00	\$568.00			
275	200	212-00006	Seeding (Native)	Acre	0.20	\$ 699.85	\$ 139.97	\$700.00	\$140.00			
280	200	212-00032	Soil Conditioning	Acre	0.20	\$ 2,384.67	\$ 476.93	\$2,175.00	\$435.00			
285	200	213-00003	Mulching (Weed Free)	Acre	0.20	\$ 622.09	\$ 124.42	\$620.00	\$124.00			
370	200	304-06000	Aggregate Base Course (Class 6)	Ton	1,302	\$ 12.19	\$ 15,871.38	\$15.00	\$19,530.00			
400	200	412-00900	Concrete Pavement (9 inch)	SY	4,350	\$ 38.85	\$ 169,997.50	\$39.84	\$173,304.00			
462	200	506-01020	Geogrid Reinforcement/SMCO#6 Tensar BX-1100	SY	4,350	\$ 5.40	\$ 23,490.00	\$5.50	\$23,925.00			
680	200	609-21020	Curb and Gutter Type 2 (Section II-B)	LF	250	\$ 11.03	\$ 2,757.50	\$12.90	\$3,225.00			
710	200	612-00002	Delineator (Type II)	Ea	10	\$ 24.14	\$ 241.40	\$25.70	\$257.00			
1096	200	625-00001	Construction Surveying (Hourly)	HR	40	\$ 100.00	\$ 4,000.00	\$125.00	\$5,000.00			
1100	200	626-00000	Mobilization***	LS	1	\$ -	\$ -	\$0.00	\$25,000.00			
1115	200	627-00011	Pavement Marking Paint (Waterborne)	Gal	20	\$ 41.23	\$ 824.60	\$39.00	\$780.00			
1140	200	630-00000	Flagging	HR	780	\$ 12.07	\$ 9,414.60	\$22.00	\$17,160.00			
1145	200	630-00007	Traffic Control Inspection	Day	4	\$ 46.09	\$ 184.36	\$82.00	\$328.00			
1150	200	630-00012	Traffic Control Management	Day	26	\$ 321.00	\$ 8,346.00	\$430.00	\$11,180.00			
1205	200	630-80370	Concrete Barrier (Temporary)	LF	500	\$ 13.69	\$ 6,845.00	\$18.60	\$9,300.00			
1515	200	630-80380	Traffic Cone / SMCO #004	Ea	50	\$ 7.70	\$ 385.00	\$7.00	\$350.00			
1525	200	208-01622	Sweeping (With Pickup Broom) / SMCO #004	HR	60	\$ 130.00	\$ 7,800.00	\$121.21	\$7,272.60			
							Total:	\$ 325,153.05		\$396,081.06		
										Anticipated cost savings of project extension versus separately advertised and awarded project: 22%		

ENCL #2

**Added item, not in current contract for 16639. Contractor agrees to perform at 2010 Cost Data Book Average Bid Price.
 ***Mobilization: Would not apply to currently awarded project. Mobilization for separately advertised and awarded project is estimated.
 *1 Prices based on average price (per each item) of 6 bidders from 16639.

COLORADO DEPARTMENT OF TRANSPORTATION CATEGORICAL EXCLUSION DETERMINATION	Date: 11/14/2007	Revision Date: 03/20/2012	Project Code #: 16639
	Project #: IM 392A-012		
Project Name: SH 392 & I-25 Interchange Reconstruction			
Project Description: INTERCHANGE RECONSTRUCTION			

A. Categorical Exclusion Project Determination

1. This project fits Categorical Exclusion or Programmatic CE number 23 CFR 771.117 PARAGRAPH (D) (3)
2. All required Clearance Actions indicated in Part B below have been completed. All Permits and Additional Requirements indicated in Part C below will be obtained before project ad.
3. No significant environmental impacts will result from this project. The Region Planning and Environmental manager (RPEM) will ensure implementation of required mitigation commitments.
4. CDOT Form #463 dated 12/15/2010 (Revised 03/20/2012) is attached.

B. Clearance Actions

REQUIRED	DATE COMPLETED	REQUIRED	DATE COMPLETED
<input checked="" type="checkbox"/> Air Quality (hot spot analysis)	10/22/2008	<input checked="" type="checkbox"/> Paleontology	10/22/2008
<input checked="" type="checkbox"/> Noise	10/22/2008	<input checked="" type="checkbox"/> Archaeology	10/22/2008
<input type="checkbox"/> Hazardous Waste		<input checked="" type="checkbox"/> History	10/22/2008
<input checked="" type="checkbox"/> ISA Checklist	10/22/2008	<input checked="" type="checkbox"/> Historic Bridge	10/22/2008
<input type="checkbox"/> MESA (or Phase 1)		<input checked="" type="checkbox"/> 4(f)	10/22/2008
<input checked="" type="checkbox"/> Threatened or Endangered Species	10/22/2008	<input type="checkbox"/> 6(f) Agreements	
<input checked="" type="checkbox"/> Wetland Delineation (survey)	10/22/2008	<input checked="" type="checkbox"/> Other	10/22/2008

All clearance requirements have been completed for the work indicated in the CDOT Form #463 referenced above.

RPEM Signature _____ Date 12/19/2008 Region # 04

I concur in the above category designation and the scope of environmental clearance/permits indicated.

FHWA Division Administrator Signature (when required) (Please return form to RPEM) _____ Date 12/30/2008

C. Permits and Additional Requirements

REQUIRED	DATE COMPLETED	REQUIRED	DATE COMPLETED
<input checked="" type="checkbox"/> 404 Permit	09/08/2009	<input type="checkbox"/> Division of Wildlife SB 40	
<input type="checkbox"/> 401 Certification		<input checked="" type="checkbox"/> Wetland Finding	01/07/2011
<input type="checkbox"/> 402 Certification		<input type="checkbox"/> APCD Bridge/Structure Demo permit	
<input checked="" type="checkbox"/> Const Stormwater Permit (CDPS)	07/01/2011	<input type="checkbox"/> Hazardous Material (Phase II)	
<input type="checkbox"/> Const Dewatering Permit		<input type="checkbox"/> 6(f) Completion	
<input type="checkbox"/> Floodplains Development Permit		<input checked="" type="checkbox"/> Other	
		SWMP REVIEW BY J. GOREK	03/14/2012

D. Comments

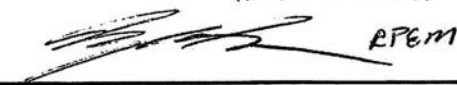
The project limits have been extended and are now reflected in this clearance dated 03/20/2012 *11/20/2012 HOCH*
 RPEM

E. Environmental Project Certification

All clearance and permit requirements for this project have been completed and mitigation included in the FOR set of plans and specifications dated 07/30/2009. The appropriate documentation is on file in the Region office.

RPEM Signature _____ Date 08/03/2009

Note to Project Manager: Any changes to the plans and specifications after the date of the RPEM signature in part B that affect environmental impacts or mitigation must be approved by the RPEM.

Distribution: _____ Previous editions are obsolete and may not be used CDOT Form #128a

03/22/2012 RPEM (original); copies to: Project Manager, Region Right of Way (if ROW required), Central Files

ENCL # 3

COLORADO DEPARTMENT OF TRANSPORTATION DESIGN DATA Page 1 to 3 Status: <input type="checkbox"/> Preliminary <input type="checkbox"/> Final <input checked="" type="checkbox"/> Revised		Orig. Date: 11/14/2007		Project Code # (SA#): 16639		STIP#: SSP4028	
		Rev. Date: 03/20/2012		Project #: IM 392A-012			
		Revision #: 4		PE Project Code:			
		Region #: 04		Project Description: SH 392 & I-25 Interchange Reconstruction			
Submitted By PM: NGUYENL				Approved by Program Engineer:			
Date: 12/15/2010				County: 069 069			
Revised by:		SORENSEN		SCHAFFERB		Municipality: Windsor	
Date:		03/28/2011		03/20/2012		System Code: I-Interstate	
				Oversight By: Full FHWA (NHS)			
				Planned Length: 0.713			
Geographic Location: I-25 AT SH 392 INTERCHANGE LARIMER COUNTY							
Type of Terrain: Rolling							
Description of Proposed Construction/Improvement(Attach map showing site location) INTERCHANGE RECONSTRUCTION							
1 Project Characteristics (Proposed)				Median (Type): <input checked="" type="checkbox"/> Depressed <input type="checkbox"/> Painted <input type="checkbox"/> Raised <input type="checkbox"/> None			
<input checked="" type="checkbox"/> Lighting		<input type="checkbox"/> Handicap Ramps		<input checked="" type="checkbox"/> Traffic Control Signals		<input checked="" type="checkbox"/> Striping	
<input type="checkbox"/> Curb and Gutter		<input type="checkbox"/> Curb Only		<input checked="" type="checkbox"/> Left-Turn Slots <input type="checkbox"/> Continuous		Width= 12	
<input checked="" type="checkbox"/> Sidwalk Width= 6.5'		<input checked="" type="checkbox"/> Bikeway Width= 6'		<input checked="" type="checkbox"/> Right-Turn Slots <input type="checkbox"/> Continuous		Width= 12	
<input type="checkbox"/> Parking Lane Width=		<input checked="" type="checkbox"/> Detours		Signing		<input checked="" type="checkbox"/> Construction <input checked="" type="checkbox"/> Permanent	
<input checked="" type="checkbox"/> Landscaping requirements (description): Native Landscape				<input type="checkbox"/> Other (description):			
2 Right of Way				3 Utilities (list names of known utility companies)			
ROW &/or Perm. Easement Required		Yes/No		Est. #		Fort Collins-Loveland Water District, South Fort Collins Sanitation District, CDOT Electrical lines, Comcast, See Text for rest.	
Relocation Required		Yes		7			
Temporary Easement Required:		No					
Changes in Access:		Yes		2			
Changes to Connecting Roads:		No					
		Yes		2			
4 Railroad Crossings				# of Crossings: 0			
Recommendations :							
5 Environmental		Type:		Approved On:		Project Code # Cleared Under:	
		N-CE Nonprogrammatic		12/30/2008			
Comments:							
6 Coordination							
<input checked="" type="checkbox"/> Withdrawn Lands (Power Sites, Reservoirs, Etc.) Cleared through BLM or Forest Service Office				Irrigation Ditch Name:			
<input type="checkbox"/> New Traffic Ordinance Required <input type="checkbox"/> Modify Schedule of Existing Ordinance				Municipality: Windsor			
Other:							
7 Construction Method		Advertised By:		NoAd Reason:		Entity / Agency Contact Name:	
		State				Fort Collins/ Rick Richter	
						Phone #:	
						970 221-6798	
8 Safety Considerations				Project Under: AASHTO			
<input type="checkbox"/> Variance in Minimum Design Standards Required				Guardrail meets current standards: No			
<input type="checkbox"/> Justification Attached		<input type="checkbox"/> Request to be Submitted		<input type="checkbox"/> Safety project not all standards addressed		Comments: Guardrail to be updated as part of this project	
<input type="checkbox"/> Bridge(see item 12)		<input type="checkbox"/> See Remarks					
<input type="checkbox"/> Stage Construction (explain in remarks)							
3R projects							
Safety Evaluation Complete (date):							

ENCL #3 : ATTACHMT p 1 of 3

Page 2 of 3	Project Code #(SA#):	Project #:	Revise date:
16639	IM 392A-012	IM 392A-012	03/20/2012
Use Columns A, B, C, D and/or E to identify facility described below			
A = 025A	B = 392A	C =	D =
E =			
9 Traffic			
Current Year	ADT 32900	18900	4800
2009	DHV 3290	1512	800
	DHV % Trucks 11.6	5.5	5.5
Future Year	ADT 51719	7400	15200
2035	DHV 5172	830	910
Facility Location			
	<input type="checkbox"/> Industrial	<input type="checkbox"/> Commercial	<input type="checkbox"/> Industrial
	<input type="checkbox"/> Residential	<input checked="" type="checkbox"/> Other	<input type="checkbox"/> Commercial
		<input type="checkbox"/> Residential	<input checked="" type="checkbox"/> Other
			<input type="checkbox"/> Residential
			<input type="checkbox"/> Commercial
			<input type="checkbox"/> Other
10 Roadway Class			
Route	025A	392A	
Reipt	261.790	99.576	
Endreipt	263.310	100.289	
Functional Classification	F	M	
Facility type	F		
Rural Code	2		
11 Design Standards			
Standard	Existing	Proposed	Ultimate
Design Variance Required (substandard items are identified with an * in 1 st column & clarify as design variance with CDOT Form #464)			
Width of Travel Lanes	12	12	12
Shoulder width l/outside	4	4	4
Shoulder width r/outside	10	10	10
Design Speed	80	70	70
Cross Slope	2 %	1.5%	1.5%
Max. super-elevation rate	6	TAN	TAN
Min. Radius	3050	TAN	TAN
Min. Horizontal SSD	910	UNCH	UNCH
Min. Vertical SSD	910	UNCH	UNCH
Max Grade	4	UNCH	UNCH
Design Decision Letter Required (substandard items are identified with an * in 1 st column & clarify with decision letter)			
Typical Section Type	A	A	A
# of Travel Lanes	4	4	4
Side Slope Dist. (ft)	12	12	12
Median Width	52	52	52
Posted Speed	75	75	75
	URB	URB	URB
	4	2	4
	12	12	12
	NA	NA	NA
	45	35	45
	B	D	B
	2	2	2
	12	12	12
	N/A	N/A	N/A
	35-55	35-55	35-55
	RAMP	RAMP	RAMP
	1	1	1
	VAR	VAR	VAR
	12	12	12
	N/A	N/A	N/A
	35	45	35

ENCL #3: ATTACHMT p2 of 3

Page 3 of 3	Project Code #(SA#): 16639	Project #: IM 392A-012	Revise Date: 03/20/2012							
12 Major Structures S= to stay, R= to be removed, P= proposed new structure										
Structure ID#	▼	Length	Reference Point	Feature Intersected	Standard Width	Structure Roadway	Structural Capacity	Horizontal Clearance	Vertical Clearance	Year Built
C-17-ER	R	210	100	I-25/ SH 392	28	392	33		16.92	1965

Proposed Treatment of Bridges to Remain in Place(address bridge rail, capacity, and allowable surfacing thickness):

13 Remarks

A new structure (C-17-FK) is proposed to replace C-17-ER.
 The new structure is a 2-Span(west span 143'-6" and east span 125'-6") Post-Tensioned Precast Concrete U Girder Bridge. 104'-0" Roadway, Sidewalk Flowline to Sidewalk Flowline, with 90 degree skew, 6'-6" Sidewalk on each side, bridge rail type 7 (Special) with pedestrian fence (special).

SH 392 has a raised median and I-25 has a depressed median.

Utilities Continued: Poudre Valley Rural Electric Association, US Cable, Xcel Energy

Note the entry "UNCH" in the Design Standards section. UNCH = Unchanged. The scope of this project is to reconstruct 392 over I-25 and the ramps, but I-25 mainline alignments and typical section will not be reconstructed or changed as part of this project. The only change to I-25 mainline will be that the existing bridge piers and barrier in the I-25 median will be removed and replaced by median cable barrier. The proposed structure spans I-25 mainline.

Note that the NB I-25 on ramp will have a grade of 6.05%. The "Policy on Geometric Design of Highways and Streets" allows for a grade of up to 5%, however there is exception for up to 7% in certain cases. CDOT has obtained FHWA concurrence for a grade of 6.05% and the documentation is on file.

Note that the minimum allowed radius for the ramps is given as 833' (PGDHS Exh. 3-26, e=6%, design speed = 50 mph). The NB off ramp has a 400' minimum radius. However, the 400' radius occurs in the terminal area where it is acceptable to have a lower design speed. The curve meets a design speed of 35 mph, which is acceptable. All other ramp radii are well above the 833' minimum. See the "Ramps" section on page 823 of the PGDHS. All criteria are met.

The same holds true for the SB off ramp 410' vertical SSD. The minimum vertical SSD allowed for the ramp proper is 425'. The 410' vertical SSD occurs in the ramp terminal where a lower design speed is allowed. All criteria are met.

ENCL #3: ATTACHMT p 3 of 3

Currier, Gray

From: Donna.Harmelink@dot.gov
Sent: Tuesday, March 20, 2012 5:52 PM
To: Currier, Gray
Subject: RE: FHWA Concurrence for use of Federal funds for extension to CDOT Project IM 392A-012, Subaccount 16639

Gray

I have reviewed the 128 and 463 for the extension of Project IM 392A-012. I concurred that Federal Aid Funds can be used for the construction of the extension. Since this change is for a Project Termini Extensions FHWA will need to review and sign the CMO when it is written.

Thanks
Dona

From: Currier, Gray [mailto:Gray.Currier@DOT.STATE.CO.US]
Sent: Tuesday, March 20, 2012 3:05 PM
To: Harmelink, Donna (FHWA)
Cc: Ellis, Scott; Zamora, Laura
Subject: FHWA Concurrence for use of Federal funds for extension to CDOT Project IM 392A-012, Subaccount 16639

Donna,

As previously discussed, CDOT Region 4 respectfully requests to extend the subject project 450' to the east. As we saw when you and I toured the site this morning, this extension will remove and replace the deteriorated existing asphalt pavement approach-to-project with a new concrete pavement approach-to-project. The new pavement is needed to accommodate westbound vehicles' braking and turning movements, in advance of the new concrete intersection at SH 392 and Westgate Drive currently being built by the project.

The Categorical Exclusion Form 128a (attached) and the Form 463 (attached) have been updated to reflect the proposed extension. Sufficient funds exist in the current project to perform the work. Please indicate FHWA's concurrence in the use of Federal funds for this proposed project extension by return e-mail. Thank you very much.

Gray Currier, PE-1, CDOT Project Engineer
SH 392 & I-25 Interchange Reconstruction
Project No. IM 392A-012, Subaccount 16639
Cell: (970) 962-4057; gray.currier@dot.state.co.us

<< File: 16639 CatExc Revised.pdf >> << File: 16639 Form 463 Revised.pdf >>

ENCL #4

Appendix C

Project Termini Extension Type II (Paving Plus Time)

COLORADO DEPARTMENT OF TRANSPORTATION CONTRACT MODIFICATION ORDER	Project No.: IM392A-012	Project Code (SA#): 16639
	Location: SH 392 & I-25 INTERCHANGE RECO	
	Date: 04/04/2012	Project Order No.: 011
	Estimated cost to project: <input checked="" type="checkbox"/> Increase <input type="checkbox"/> Decrease \$ 275,009.19	
Contractor: EDWARD KRAEMER AND SONS INCORPORATED	Total additional days allowed to complete work: 45	
Complete Address: ONE PLAIN VIEW RD PLAIN, WI 53577	Federal Oversight? <input type="checkbox"/> Yes <input type="checkbox"/> No	
Modification Title: Extension of Project 450' East		

The following items are hereby added to your contract at agreed unit prices:

Project	Catg	Line	Item No.	Description	Quantity	Unit	Unit Price	Total
16639-BID	0200	0268	210-04010	Adj Manhole SMCO#11	2.000	EACH	\$419.43000	\$838.86
Total added items:								\$838.86

The quantities of the following existing contract items are hereby modified as follows:

Project	Catg	Line	Item No.	Description	Quantity	Unit	Unit Price	Total
16639-BID	0200	0040	202-00220	*Removal of Asphalt Mat	3,833.000	SY	\$3.05000	\$11,690.65
16639-BID	0200	0050	202-00250	*Removal of Pavement Marking	500.000	SF	\$0.91000	\$455.00
16639-BID	0200	0065	202-00810	*Removal of Ground Sign	1.000	EACH	\$125.71000	\$125.71
16639-BID	0200	0110	203-00060	*Embankment Material (Complete In Place)	13.000	CY	\$4.83000	\$62.79
16639-BID	0200	0115	203-00062	*Embankment Material (Complete In Place) (Special)	3,862.000	CY	\$5.59000	\$21,588.58
16639-BID	0200	0125	203-01100	*Proof Rolling	10.000	HOUR	\$81.27000	\$812.70
16639-BID	0200	0130	203-01500	*Blading	10.000	HOUR	\$86.35000	\$863.50
16639-BID	0200	0150	203-01597	*Potholing	35.000	HOUR	\$165.94000	\$5,807.90
16639-BID	0200	0175	207-00205	*Topsoil	75.000	CY	\$3.56000	\$267.00
16639-BID	0200	0185	208-00002	*Erosion Log (12 Inch)	200.000	LF	\$5.08000	\$1,016.00

I hereby accept this order, for work to be performed and prices on which payment is to be based.			
REQUIRED IN ACCORDANCE WITH INSTRUCTIONS IN THE CDOT CONSTRUCTION MANUAL		REQUIRED FOR ALL CHANGE ORDERS	
Approved by FHWA Operations Engineer:	Date:	Authorized by Project Engineer:	Date:
OPTIONAL		Contractor Representative:	Date:
Approved by Region Transportation Director:	Date:	Approved by Resident Engineer:	Date:
		<input type="checkbox"/> Participating <input type="checkbox"/> Non-participating <input type="checkbox"/> Participation as noted	
		Approved Funding by Region Program Engineer:	Date:

Previous editions may be used until supplies are exhausted

CDOT Form 90a 03/03

Appendix C

COLORADO DEPARTMENT OF TRANSPORTATION CONTRACT MODIFICATION ORDER	Project No.: IM392A-012	Project Code (SA#): 16639
	Location: SH 392 & I-25 INTERCHANGE RECO	
Contractor: EDWARD KRAEMER AND SONS INCORPORATED	Date: 04/04/2012	Project Order No.: 011
Complete Address: ONE PLAIN VIEW RD PLAIN, WI 53577	Estimated cost to project: <input checked="" type="checkbox"/> Increase <input type="checkbox"/> Decrease \$ 275,009.19	
Modification Title: Extension of Project 450' East	Total additional days allowed to complete work: 45	Federal Oversight? <input type="checkbox"/> Yes <input type="checkbox"/> No

The quantities of the following existing contract items are hereby modified as follows:

Project	Catg	Line	Item No.	Description	Quantity	Unit	Unit Price	Total
16639-BID	0200	0190	208-00020	*Silt Fence	900.000	LF	\$0.98000	\$882.00
16639-BID	0200	0195	208-00034	*Gravel Bag	116.000	LF	\$4.15000	\$481.40
16639-BID	0200	0200	208-00045	*Concrete Washout Structure	3.000	EACH	\$1,036.81000	\$3,110.43
16639-BID	0200	0220	208-00206	Erosion Control Supervisor	24.000	DAY	\$25.00000	\$600.00
16639-BID	0200	0230	210-00810	*Reset Ground Sign	3.000	EACH	\$60.34000	\$181.02
16639-BID	0200	0240	210-00831	*Reset Traffic Signal Head	4.000	EACH	\$135.77000	\$543.08
16639-BID	0200	0270	210-04050	Adjust Valve Box	1.000	EACH	\$251.43000	\$251.43
16639-BID	0200	0275	212-00006	*Seeding (Native)	0.200	ACRE	\$699.85000	\$139.97
16639-BID	0200	0280	212-00032	*Soil Conditioning	0.200	ACRE	\$2,384.67000	\$476.93
16639-BID	0200	0285	213-00003	*Mulching (Weed Free)	0.200	ACRE	\$622.09000	\$124.42
16639-BID	0200	0370	304-06000	*Aggregate Base Course (Class 6)	1,156.000	TON	\$12.19000	\$14,091.64
16639-BID	0200	0400	412-00900	*Concrete Pavement (9 Inch)	3,812.000	SY	\$38.85000	\$148,096.20
16639-BID	0200	0462	506-01020	*Geogrid Reinforcement SMCO#6 Tensor BX-1100 13.1'/164' (239SY/Roll)	3,812.000	SY	\$5.40000	\$20,584.80
16639-BID	0200	0665	608-00010	*Concrete Curb Ramp	17.000	SY	\$112.31000	\$1,909.27

I hereby accept this order, for work to be performed and prices on which payment is to be based.			
REQUIRED IN ACCORDANCE WITH INSTRUCTIONS IN THE CDOT CONSTRUCTION MANUAL		REQUIRED FOR ALL CHANGE ORDERS	
Approved by FHWA Operations Engineer:	Date:	Authorized by Project Engineer:	Date:
OPTIONAL		Contractor Representative:	Date:
Approved by Region Transportation Director:	Date:	Approved by Resident Engineer:	Date:
		<input type="checkbox"/> Participating <input type="checkbox"/> Non-participating <input type="checkbox"/> Participation as noted Approved Funding by Region Program Engineer: _____ Date: _____	

Previous editions may be used until supplies are exhausted

CDOT Form 90a 03/03

Appendix C

COLORADO DEPARTMENT OF TRANSPORTATION CONTRACT MODIFICATION ORDER	Project No.: IM392A-012	Project Code (SA#): 16639
	Location: SH 392 & I-25 INTERCHANGE RECO	
Contractor: EDWARD KRAEMER AND SONS INCORPORATED	Date: 04/04/2012	Project Order No.: 011
Complete Address: ONE PLAIN VIEW RD PLAIN, WI 53577	Estimated cost to project: <input checked="" type="checkbox"/> Increase <input type="checkbox"/> Decrease \$ 275,009.19	
Modification Title: Extension of Project 450' East	Total additional days allowed to complete work: 45	Federal Oversight? <input type="checkbox"/> Yes <input type="checkbox"/> No

The quantities of the following existing contract items are hereby modified as follows:

Project	Catg	Line	Item No.	Description	Quantity	Unit	Unit Price	Total
16639-BID	0200	0680	609-21020	*Curb and Gutter Type 2 (Section II-B)	100.000	LF	\$11.03000	\$1,103.00
16639-BID	0200	0710	612-00002	*Delineator (Type II)	10.000	EACH	\$24.14000	\$241.40
16639-BID	0200	0805	614-00011	*Sign Panel (Class I)	6.000	SF	\$20.11000	\$120.66
16639-BID	0200	0825	614-01502	*Steel Sign Support (2-Inch Round)(Post & Socket)	10.000	LF	\$13.07000	\$130.70
16639-BID	0200	1096	625-00001	*Construction Surveying (Hourly)	40.000	HOUR	\$100.00000	\$4,000.00
16639-BID	0200	1110	627-00005	*Epoxy Pavement Marking	3.000	GAL	\$82.47000	\$247.41
16639-BID	0200	1115	627-00011	*Pavement Marking Paint (Waterborne)	20.000	GAL	\$41.23000	\$824.60
16639-BID	0200	1140	630-00000	*Flagging	780.000	HOUR	\$12.07000	\$9,414.60
16639-BID	0200	1145	630-00007	*Traffic Control Inspection	6.000	DAY	\$46.09000	\$276.54
16639-BID	0200	1150	630-00012	*Traffic Control Management	39.000	DAY	\$321.00000	\$12,519.00
16639-BID	0200	1205	630-80370	Concrete Barrier (Temporary)	500.000	LF	\$13.69000	\$6,845.00
16639-BID	0200	1515	630-80380	*Traffic Cone SMCO#004, 08/2011 U	50.000	EACH	\$7.70000	\$385.00

I hereby accept this order, for work to be performed and prices on which payment is to be based.			
REQUIRED IN ACCORDANCE WITH INSTRUCTIONS IN THE CDOT CONSTRUCTION MANUAL		REQUIRED FOR ALL CHANGE ORDERS	
Approved by FHWA Operations Engineer:	Date:	Authorized by Project Engineer:	Date:
OPTIONAL		Contractor Representative:	Date:
		Approved by Resident Engineer:	Date:
Approved by Region Transportation Director:	Date:	<input type="checkbox"/> Participating <input type="checkbox"/> Non-participating <input type="checkbox"/> Participation as noted	
		Approved Funding by Region Program Engineer:	Date:

Previous editions may be used until supplies are exhausted

CDOT Form 90a 03/03

Appendix C

COLORADO DEPARTMENT OF TRANSPORTATION CONTRACT MODIFICATION ORDER	Project No.: IM392A-012	Project Code (SA#): 16639
	Location: SH 392 & I-25 INTERCHANGE RECO	
Contractor: EDWARD KRAEMER AND SONS INCORPORATED	Date: 04/04/2012	Project Order No.: 011
Complete Address: ONE PLAIN VIEW RD PLAIN, WI 53577	Estimated cost to project: <input checked="" type="checkbox"/> Increase <input type="checkbox"/> Decrease \$ 275,009.19	
Modification Title: Extension of Project 450' East	Total additional days allowed to complete work: 45	Federal Oversight? <input type="checkbox"/> Yes <input type="checkbox"/> No

The quantities of the following existing contract items are hereby modified as follows:

Project	Catg	Line	Item No.	Description	Quantity	Unit	Unit Price	Total
16639-BID	0200	1525	203-01622	*Sweeping (With Pickup Broom) SMCO#004 08/2011 U	30.000	HOUR	\$130.00000	\$3,900.00

Total changed item quantities: \$274,170.33

Total for Contract Modification Order 011: \$275,009.19

I hereby accept this order, for work to be performed and prices on which payment is to be based.			
REQUIRED IN ACCORDANCE WITH INSTRUCTIONS IN THE CDOT CONSTRUCTION MANUAL		REQUIRED FOR ALL CHANGE ORDERS	
Approved by FHWA Operations Engineer:	Date:	Authorized by Project Engineer:	Date:
OPTIONAL		Contractor Representative:	Date:
Approved by Region Transportation Director:	Date:	Approved by Resident Engineer:	Date:
		<input type="checkbox"/> Participating <input type="checkbox"/> Non-participating <input type="checkbox"/> Participation as noted	
		Approved Funding by Region Program Engineer:	Date:

Previous editions may be used until supplies are exhausted

CDOT Form 90a 03/03

Significant Change to Work (Change Wall Type)

MEMORANDUM

DEPARTMENT OF TRANSPORTATION

4201 E. Arkansas Avenue
Denver, Colorado 80222
Phone 303-757-9011



DATE: July 4, 2013 RE: 11111 / NH 66-063
Route 66 - East

TO: (Resident Engineer or Program Engineer as per Region requirements)

FROM: (Project Engineer)

SUBJECT: Contract Modification Order #7, Design Change-Wall B

This change order was written to eliminate retaining Wall B and to construct a rock cut on a 0.5:1 slope with rock anchor stabilization.

As part of the Right-of-Way Agreement with The Bluffers Homeowners Association, CDOT agreed not to disturb a rock outcropping along a cut slope between Station 589 and Station 591 left. Consultant Design Engineering included a ground nail wall at this cut in order to comply with the Agreement. A field investigation by the Project Engineer revealed that a 0.5:1 cut slope could be constructed at significant cost savings while still meeting the Department's commitment to the locals. Ron Anders of Staff Geotechnical agreed that a slope would be stable on a 0.5:1 with rock anchors.

The work will consist of additional unclassified excavation, rock anchors, and a lump sum settlement with the Contractor for expenses already incurred for the wall construction. A detailed tabulation of these expenses is attached. Compensation for unclassified excavation and rock anchors will be at Contract unit prices. We do not foresee exceeding the plan quantity for rock anchors; therefore, the quantity for this item will not be increased.

This work does not impact the critical path; therefore, no additional time is required.

The projected cost for this project including this change order is \$11,650,000.00 or 0.06 percent under the current allotment as shown on the attached Project Financial Statement. The budget summary is as follows:

Current Project Budget	\$11,656,459.00	
Projected Costs to Completion	<u>\$11,650,000.00</u>	
Projected Surplus (Deficit)	\$6,459.00	0.06%

A budget action will not be required for this change. In order to avoid a project delay, the Contractor has been directed by Form 105 to begin work. A copy of the completed Form 105 is attached.

This change order was discussed with Rock Howell, Region Program Engineer and with Cal Tollan, Project Development Area Engineer, on June 26, 2013. Concurrence was obtained from Dan Van Der Wagon, Project Manager for this project on June 23, 2013. Written concurrence from Raoul Jesus of FHWA is attached.

Appendix C

Significant Change to Work (Change Wall Type)

COLORADO DEPARTMENT OF TRANSPORTATION CONTRACT MODIFICATION ORDER		Project No.: NH 66-063	Project Code (SA#): 11111	
		Location: Route 66 - East		
		Date: July 4, 2013	Project Order No.: 7	
Contractor: Good Aim Construction		Estimated cost to project: <input type="checkbox"/> Increase <input checked="" type="checkbox"/> Decrease (\$195,019.00)		
Complete Address: 1455 Lost Road Aurora, Co 80011		Total additional days allowed to complete work: 0	Federal Oversight? <input checked="" type="checkbox"/> Yes <input type="checkbox"/> No	
Modification Title: Design Change-Wall B				

Your Contract is hereby modified to include a design change at Wall B. This change order was written to eliminate the wall and to construct the slope on a 0.5:1 slope with rock anchor stabilization.

The work will consist of additional unclassified excavation, rock anchors, and a lump sum settlement for expenses already incurred for the wall construction. Compensation for unclassified excavation and rock anchors will be at Contract unit prices.

<u>ITEM DESCRIPTION</u>	<u>UNIT</u>	<u>PREVIOUS QUANTITY</u>	<u>ADDED QUANTITY</u>	<u>REV. PLAN QUANTITY</u>	<u>UNIT PRICE</u>	<u>INCR. COST TO PROJECT</u>
INCREASE:						
203 Unclassified Excavation	CY	500,271	2,900	503,171	\$3.90	\$11,310.00
DELETE:						
504 Ground Nail Wall	SF	10,258	(6,720)	3,538	\$33.60	(\$225,792.00)
ADD:						
900 Added Costs-Wall B Deletion	LS	0	1	1	\$19,463.00	\$19,463.00
TOTAL ESTIMATED DECREASED COST TO PROJECT						(\$195,019.00)

This work does not impact the critical path, therefore, no additional time is required.

The Contractor accepts this Change Order for work to be performed and prices on which payment is to be based.			
REQUIRED IN ACCORDANCE WITH INSTRUCTIONS IN THE CDOT CONSTRUCTION MANUAL		REQUIRED FOR ALL CHANGE ORDERS	
Approved by FHWA Operations Engineer:	Date:	Authorized by Project Engineer:	Date:
OPTIONAL		Contractor Representative:	Date:
Approved by Region Transportation Director:	Date:	Approved by Resident Engineer:	Date:
		<input type="checkbox"/> Participating <input type="checkbox"/> Non-participating <input type="checkbox"/> Participation as noted	
		Approved Funding by Region Program Engineer:	Date:

CDOT Form 90 07/02

Change Basis of Payment (From CY to FA)

MEMORANDUM

DEPARTMENT OF TRANSPORTATION

4201 E. Arkansas Avenue
Denver, Colorado 80222
Phone 303-757-9011



DATE: July 24, 2013 RE: 11111 / NH 66-063
Route 66 - East

TO: (Resident Engineer or Program Engineer as required by Region)

FROM: (Project Engineer)

SUBJECT: Contract Modification Order #6, Method of Measurement for Sediment Removal

This change order was written to change the method of measurement for Sediment Removal from cubic yard to force account.

The plans require that sediment removal be paid on a cubic yard basis. Due to the large quantities of erosion bales and silt fence on this project, it is impractical and inefficient to measure and calculate the fractions of cubic yards at various locations. This was discussed with the Contractor who agreed to accept payment on a force account basis.

There will be no additional cost for this change order.

This change does not impact the critical path; therefore, no additional time is required.

The projected cost for this project including this change order is \$11,650,000.00 or 0.06 percent under the current allotment as shown on the attached Project Financial Statement. The budget summary is as follows:

Current Project Budget	\$11,656,459.00	
Projected Costs to Completion	<u>\$11,650,000.00</u>	
Projected Surplus (Deficit)	\$6,459.00	0.06%

A budget action will not be required for this change. The Contractor has been directed by Form 105 to accept this change in method of measurement. A copy of the completed Form 105 is attached.

This change order was discussed with Rock Howell, Region Program Engineer and with Hamid Sullivan, Project Development Area Engineer, on July 21, 2013.

Appendix C

Change Basis of Payment (From CY to FA)

COLORADO DEPARTMENT OF TRANSPORTATION CONTRACT MODIFICATION ORDER		Project No.: NH 66-063	Project Code (SA#): 11111	
		Location: Route 66 - East		
Contractor: Good Aim Construction		Date: July 4, 2013	Project Order No.: 6	
		Estimated cost to project: <input type="checkbox"/> Increase <input type="checkbox"/> Decrease \$0.00		
Complete Address: 1455 Lost Road Aurora, CO 80011		Total additional days allowed to complete work: 0	Federal Oversight? <input checked="" type="checkbox"/> Yes <input type="checkbox"/> No	
Modification Title: Method Of Measurement for Sediment Removal				

Your Contract is hereby modified to change the method of measurement for sediment removal from cubic yard to force account.

The items affected by this change are as follows:

<u>ITEM DESCRIPTION</u>	<u>UNIT</u>	<u>PREVIOUS QUANTITY</u>	<u>ADDED QUANTITY</u>	<u>REV. PLAN QUANTITY</u>	<u>UNIT PRICE</u>	<u>INCR. COST TO PROJECT</u>
DELETE:						
250 Sediment Removal	CY	2,000	(2,000)	0	\$10.00	(\$20,000.00)
ADD:						
900 Sediment Removal	FA	0	20,000	20,000	\$1.00	\$20,000.00
TOTAL ESTIMATED INCREASED COST TO PROJECT						\$0.00

This change does not impact the critical path; therefore, no additional time is required.

The Contractor accepts this Change Order for work to be performed and prices on which payment is to be based.			
REQUIRED IN ACCORDANCE WITH INSTRUCTIONS IN THE CDOT CONSTRUCTION MANUAL		REQUIRED FOR ALL CHANGE ORDERS	
Approved by FHWA Operations Engineer:	Date:	Authorized by Project Engineer:	Date:
OPTIONAL		Contractor Representative:	Date:
Approved by Region Transportation Director:	Date:	Approved by Resident Engineer:	Date:
		<input type="checkbox"/> Participating <input type="checkbox"/> Non-participating <input type="checkbox"/> Participation as noted	
		Approved Funding by Region Program Engineer:	Date:

CDOT Form 90 07/02

Administrative Settlement of Claim

MEMORANDUM

DEPARTMENT OF TRANSPORTATION

4201 E. Arkansas Avenue
Denver, Colorado 80222
Phone 303-757-9011



DATE: October 25, 2013 Re: 11111/NH 66-066
Route 66-South

TO: (Resident Engineer or Program Engineer per Region requirements)

FROM: (Project Engineer)

SUBJECT: Contract Modification Order #11, Administrative Claim Settlement

This change order was written to settle a claim brought by the Contractor for delays, disruptions, and recoup of liquidated damages. The Contractor initially requested \$450,000 for delays and disruptions caused by right-of-way acquisition, utility relocation, design changes, and Prebbles mouse trapping. In addition, in the last stages of the project, the Contractor incurred \$70,000 of the liquidated damages they feel were beyond their control. Without admitting liability or fault, CDOT has agreed to an administrative settlement in order to avoid additional costs regarding this claim. As agreed to by the parties involved, a lump sum payment of \$50,000 will be made to the Contractor on the final estimate for the delays and disruption portion of the claim. In addition, CDOT will amend time charges to reflect no liquidated damages. Complete details of this claim will be maintained in the claim package of the project records.

The projected cost for this project including this change order is \$11,447,082.96 or 1.5 percent under the current allotment as shown on the attached Project Financial Statement. The budget summary is as follows:

Current Project Budget	\$11,625,259.00	
Projected Costs to Completion	<u>\$11,447,082.96</u>	
Projected Surplus (Deficit)	\$178,176.04	(1.5%)

This administrative settlement was recommended and approved by Gene Overseer, Chief Engineer, on September 20, 2013. Concurrence was obtained from Brent Ripperton, Region Program Engineer, and from Jess Coolguy, Region Transportation Director, on September 20, 2013. This change order was discussed with Jimmy Cero, Project Development Area Engineer, on September 5, 2013. FHWA pre-approval is not required for this change order, because the total cost is less than \$250,000.00.

A budget action will not be required as a result of this change order.

Appendix C

Administrative Settlement of Claim

COLORADO DEPARTMENT OF TRANSPORTATION CONTRACT MODIFICATION ORDER	Project No.: NH 66-066	Project Code (SA#): 11111																					
	Location: Route 66-South																						
	Date: October 25, 2013	Project Order No.: 11																					
Contractor: Good Aim Construction Inc.	Estimated cost to project: <input checked="" type="checkbox"/> Increase <input type="checkbox"/> Decrease \$50,000.00																						
Complete Address: 666 Lost Road Aurora, CO 80011	Total additional days allowed to complete work: 0	Federal Oversight? <input checked="" type="checkbox"/> Yes <input type="checkbox"/> No																					
Modification Title: Administrative Claim Settlement																							
<p>This change order was written to settle a claim brought by the Contractor for delays, disruptions, and recoup of liquidated damages. CDOT has agreed to an administrative settlement as follows:</p> <p>A lump sum payment of \$50,000.00 will be made to the Contractor on the final estimate for the delays and disruption portion of the claim. In addition, CDOT will amend time charges to reflect no liquidated damages.</p> <p>The items affected by this change are listed below:</p> <table style="width: 100%; border-collapse: collapse;"> <thead> <tr> <th style="text-align: left;"><u>ITEM DESCRIPTION</u></th> <th style="text-align: center;"><u>UNIT</u></th> <th style="text-align: center;"><u>PREVIOUS QUANTITY</u></th> <th style="text-align: center;"><u>ADDED QUANTITY</u></th> <th style="text-align: center;"><u>REV. PLAN QUANTITY</u></th> <th style="text-align: center;"><u>UNIT PRICE</u></th> <th style="text-align: center;"><u>INCR. COST TO PROJECT</u></th> </tr> </thead> <tbody> <tr> <td><u>ADD:</u> 900 Claim Settlement</td> <td style="text-align: center;">LS</td> <td style="text-align: center;">0</td> <td style="text-align: center;">1</td> <td style="text-align: center;">1</td> <td style="text-align: right;">\$50,000.00</td> <td style="text-align: right;"><u>\$50,000.00</u></td> </tr> <tr> <td colspan="6" style="text-align: right;">TOTAL ESTIMATED INCREASED COST TO PROJECT</td> <td style="text-align: right;">\$50,000.00</td> </tr> </tbody> </table> <p>By signing below, the Contractor accepts this change as full and final settlement of this claim.</p>			<u>ITEM DESCRIPTION</u>	<u>UNIT</u>	<u>PREVIOUS QUANTITY</u>	<u>ADDED QUANTITY</u>	<u>REV. PLAN QUANTITY</u>	<u>UNIT PRICE</u>	<u>INCR. COST TO PROJECT</u>	<u>ADD:</u> 900 Claim Settlement	LS	0	1	1	\$50,000.00	<u>\$50,000.00</u>	TOTAL ESTIMATED INCREASED COST TO PROJECT						\$50,000.00
<u>ITEM DESCRIPTION</u>	<u>UNIT</u>	<u>PREVIOUS QUANTITY</u>	<u>ADDED QUANTITY</u>	<u>REV. PLAN QUANTITY</u>	<u>UNIT PRICE</u>	<u>INCR. COST TO PROJECT</u>																	
<u>ADD:</u> 900 Claim Settlement	LS	0	1	1	\$50,000.00	<u>\$50,000.00</u>																	
TOTAL ESTIMATED INCREASED COST TO PROJECT						\$50,000.00																	
The Contractor accepts this Change Order for work to be performed and prices on which payment is to be based.																							
REQUIRED IN ACCORDANCE WITH INSTRUCTIONS IN THE CDOT CONSTRUCTION MANUAL		REQUIRED FOR ALL CHANGE ORDERS																					
Approved by FHWA Operations Engineer:	Date:	Authorized by Project Engineer:	Date:																				
OPTIONAL		Contractor Representative:	Date:																				
Approved by Region Transportation Director:	Date:	Approved by Resident Engineer:	Date:																				
		<input type="checkbox"/> Participating <input type="checkbox"/> Non-participating <input type="checkbox"/> Participation as noted																					
		Approved Funding by Region Program Engineer:	Date:																				

CDOT Form 90 07/02

Design Error (Incorrect Pipe Size)

MEMORANDUM

DEPARTMENT OF TRANSPORTATION

4201 E. Arkansas Avenue
Denver, Colorado 80222
Phone 303-757-9011



DATE: August 31, 2013 RE: 11111 / NH 66-063
Route 66 - East

TO: (Resident Engineer or Program Engineer as per Region requirements)

FROM: (Project Engineer)

SUBJECT: Contract Modification Order #9, Correction of Design Error

This change order was written to correct a design error. After a 24-inch culvert had been installed at Station 66+50 right, the owner of the water rights carried by this culvert contacted the Project Engineer and stated that the culvert was inadequate to handle the required flow. Investigation revealed that the upstream culvert was a 30-inch corrugated metal pipe, although shown on the plans as a 24-inch pipe.

The basis of payment will be at the negotiated unit price of \$40.00/linear foot. This is reasonable when compared to the average bid price of \$41.00/linear foot from the 2000 Cost Data Book. Payment for removal of the previously placed 24-inch culvert will be at the unit bid price for removal of culvert.

This change does not impact the critical path; therefore, no additional time is required.

The projected cost for this project including this change order is \$1,650,000.00 or 0.4 percent under the current allotment as shown on the attached Project Financial Statement. The budget summary is as follows:

Current Project Budget	\$1,656,459.00	
Projected Costs to Completion	<u>\$1,650,000.00</u>	
Projected Surplus (Deficit)	\$6,459.00	0.4%

A budget action will not be required for this change. The Contractor has been directed by Form 105 to begin this work. A copy of the completed Form 105 is attached.

This change order was discussed with Rock Howell, Region Program Engineer and with Gary Ward, Project Development Area Engineer, on July 21, 2013.

Appendix C

Design Error (Incorrect Pipe Size)

COLORADO DEPARTMENT OF TRANSPORTATION CONTRACT MODIFICATION ORDER	Project No.: NH 66-063	Project Code (SA#): 11111
	Location: Route 66 - East	
	Date: August 21, 2013	Project Order No.: 9
Contractor: Good Aim Construction	Estimated cost to project: <input checked="" type="checkbox"/> Increase <input type="checkbox"/> Decrease \$2,760.00	
Complete Address: 1455 Lost Road Aurora, CO 80011	Total additional days allowed to complete work: 0	Federal Oversight? <input checked="" type="checkbox"/> Yes <input type="checkbox"/> No
Modification Title: Design Error Correction for Culvert		

Your Contract is hereby modified to include the correction of a design error at Station 64+50 right.

The work will consist of removing the previously placed 24-inch culvert and installing a 30-inch culvert. All work will be performed in accordance with the Contract Specifications.

The items affected by this change are as follows:

<u>ITEM DESCRIPTION</u>	<u>UNIT</u>	<u>PREVIOUS QUANTITY</u>	<u>ADDED QUANTITY</u>	<u>REV. PLAN QUANTITY</u>	<u>UNIT PRICE</u>	<u>INCR. COST TO PROJECT</u>
<u>INCREASE:</u>						
202 Removal of Culvert	LF	305	60	365	\$6.00	\$360.00
<u>ADD:</u>						
617 30-inch Culvert Pipe	LF	0	60	60	\$40.00	\$2,400.00
TOTAL ESTIMATED INCREASED COST TO PROJECT						\$2,760.00

This work does not impact the critical path; therefore, no additional time is required.

The Contractor accepts this Change Order for work to be performed and prices on which payment is to be based.			
REQUIRED IN ACCORDANCE WITH INSTRUCTIONS IN THE CDOT CONSTRUCTION MANUAL		REQUIRED FOR ALL CHANGE ORDERS	
Approved by FHWA Operations Engineer:	Date:	Authorized by Project Engineer:	Date:
OPTIONAL		Contractor Representative:	Date:
Approved by Region Transportation Director:	Date:	Approved by Resident Engineer:	Date:
		<input type="checkbox"/> Participating <input type="checkbox"/> Non-participating <input type="checkbox"/> Participation as noted	
		Approved Funding by Region Program Engineer:	Date:

CDOT Form 90 07/02

Urgent Work (Mudslide / Payment of Repair)

MEMORANDUM

DEPARTMENT OF TRANSPORTATION

4201 E. Arkansas Avenue
Denver, Colorado 80222
Phone 303-757-9011



DATE: September 30, 2013 RE: 11111 / NH 66-063
Route 66 - East

TO: (Resident Engineer or Program Engineer as per Region requirements)

FROM: (Project Engineer)

SUBJECT: Contract Modification Order #10, Mudslide Repair and Stabilization

Heavy rains on the night of September 27, 2013 caused a mudslide between Station 72+00 and Station 74+00 right. This change order provides for the performance of all work necessary to repair and stabilize the cut slope and roadway damaged by the slide.

The work will include unclassified excavation, rounding of the cut slope, replacement of a Class I sign, removal and replacement of damaged concrete pavement, and roadway sweeping.

Payment for unclassified excavation will be at the negotiated unit price of \$10.00/cubic yard for approximately 2000 cubic yards. This is reasonable when compared to the average bid price of \$14.00/cubic yard for similar quantities in the *2000 Cost Data Book*. Rounding of the cut slope will be included in the price of unclassified excavation. Payment for replacement of the Class I Sign will be at the unit bid price for Removal of Ground Sign, Sign Panel Class I, and Steel Sign Post (2 inch round). Payment for removal and replacement of the concrete pavement will be at the negotiated unit price of \$36.00/square yard. This is reasonable when compared to the average bid price for removal of concrete pavement from the *2000 Cost Data Book* plus the unit bid price for concrete pavement. Roadway sweeping will be paid at the negotiated price of \$45.00/hour. This is reasonable as shown on the attached force account analysis.

This change will delay a construction phasing switch by three working days. Therefore three working days of additional time will be required. The Contractor will be compensated \$1600.00/lump sum for additional overhead. This includes additional costs for Superintendent, trailer rental, phones, gas, fax machine, drinking water, and other miscellaneous items as listed on the attached justification from the Contractor.

The projected cost for this project including this change order is \$1,650,000.00 or 0.4 percent under the current allotment as shown on the attached Project Financial Statement. The budget summary is as follows:

Current Project Budget	\$1,656,459.00	
Projected Costs to Completion	<u>\$1,650,000.00</u>	
Projected Surplus (Deficit)	\$6,459.00	0.4%

A budget action will not be required for this change. The Contractor has been directed by Form 105 to begin this work. A copy of the completed Form 105 is attached.

This change order was discussed with Rock Howell, Region Program Engineer and with Gary Ward, Project Development Area Engineer, on July 21, 2013.

Appendix C

Urgent Work (Mudslide / Payment of Repair)

COLORADO DEPARTMENT OF TRANSPORTATION CONTRACT MODIFICATION ORDER		Project No.: NH 66-066		Project Code (SA#): 11111																																																																														
		Location: Route 66-South																																																																																
		Date: September 30, 2013		Project Order No.: 10																																																																														
Contractor: Good Aim Construction		Estimated cost to project: <input checked="" type="checkbox"/> Increase <input type="checkbox"/> Decrease \$30,142.00																																																																																
Complete Address: 14555 Lost Road Aurora, CO 80011		Total additional days allowed to complete work: 3		Federal Oversight? <input checked="" type="checkbox"/> Yes <input type="checkbox"/> No																																																																														
Modification Title: Mudslide Repair and Stabilization																																																																																		
<p>Your Contract is hereby modified to include work to repair the cut slope and roadway damaged by the mudslide on September 27, 2013, between Station 72+00 and Station 74+00 right.</p> <p>The work will include unclassified excavation, rounding of the cut slope, replacement of a Class I sign, removal and replacement of damaged concrete pavement, and roadway sweeping. Rounding of the cut slope will be included in the price of unclassified excavation.</p> <p>Three working days will be added for this work.</p> <p>The items affected by this change order are as follows:</p> <table style="width: 100%; border-collapse: collapse;"> <thead> <tr> <th style="text-align: left;"><u>ITEM DESCRIPTION</u></th> <th style="text-align: center;"><u>UNIT</u></th> <th style="text-align: center;"><u>PREVIOUS QUANTITY</u></th> <th style="text-align: center;"><u>ADDED QUANTITY</u></th> <th style="text-align: center;"><u>REV. PLAN QUANTITY</u></th> <th style="text-align: center;"><u>UNIT PRICE</u></th> <th style="text-align: center;"><u>INCR. COST TO PROJECT</u></th> </tr> </thead> <tbody> <tr> <td colspan="7"><u>ADD:</u></td> </tr> <tr> <td>203 Unclassified Excavation (CIP)</td> <td style="text-align: center;">CY</td> <td style="text-align: center;">0</td> <td style="text-align: center;">2000</td> <td style="text-align: center;">2000</td> <td style="text-align: right;">\$10.00</td> <td style="text-align: right;">\$20,000.00</td> </tr> <tr> <td>900 Mechanical Broom</td> <td style="text-align: center;">HR</td> <td style="text-align: center;">0</td> <td style="text-align: center;">4</td> <td style="text-align: center;">4</td> <td style="text-align: right;">\$45.00</td> <td style="text-align: right;">\$180.00</td> </tr> <tr> <td>900 Remove and Replace Concrete</td> <td style="text-align: center;">SY</td> <td style="text-align: center;">0</td> <td style="text-align: center;">225</td> <td style="text-align: center;">225</td> <td style="text-align: right;">\$36.00</td> <td style="text-align: right;">\$8,100.00</td> </tr> <tr> <td>900 Additional Overhead</td> <td style="text-align: center;">LS</td> <td style="text-align: center;">0</td> <td style="text-align: center;">1</td> <td style="text-align: center;">1</td> <td style="text-align: right;">\$1,600.00</td> <td style="text-align: right;">\$1,600.00</td> </tr> <tr> <td colspan="7"><u>INCREASE:</u></td> </tr> <tr> <td>202 Removal of Ground Sign</td> <td style="text-align: center;">EA</td> <td style="text-align: center;">25</td> <td style="text-align: center;">1</td> <td style="text-align: center;">26</td> <td style="text-align: right;">\$50.00</td> <td style="text-align: right;">\$50.00</td> </tr> <tr> <td>614 Sign Post (2 inch round)</td> <td style="text-align: center;">LF</td> <td style="text-align: center;">100</td> <td style="text-align: center;">12</td> <td style="text-align: center;">112</td> <td style="text-align: right;">\$9.00</td> <td style="text-align: right;">\$108.00</td> </tr> <tr> <td>614 Sign Panel (Class I)</td> <td style="text-align: center;">SF</td> <td style="text-align: center;">350</td> <td style="text-align: center;">8</td> <td style="text-align: center;">358</td> <td style="text-align: right;">\$13.00</td> <td style="text-align: right;">\$104.00</td> </tr> <tr> <td colspan="6" style="text-align: right;">TOTAL ESTIMATED INCREASED COST TO PROJECT</td> <td style="text-align: right;">\$30,142.00</td> </tr> </tbody> </table>						<u>ITEM DESCRIPTION</u>	<u>UNIT</u>	<u>PREVIOUS QUANTITY</u>	<u>ADDED QUANTITY</u>	<u>REV. PLAN QUANTITY</u>	<u>UNIT PRICE</u>	<u>INCR. COST TO PROJECT</u>	<u>ADD:</u>							203 Unclassified Excavation (CIP)	CY	0	2000	2000	\$10.00	\$20,000.00	900 Mechanical Broom	HR	0	4	4	\$45.00	\$180.00	900 Remove and Replace Concrete	SY	0	225	225	\$36.00	\$8,100.00	900 Additional Overhead	LS	0	1	1	\$1,600.00	\$1,600.00	<u>INCREASE:</u>							202 Removal of Ground Sign	EA	25	1	26	\$50.00	\$50.00	614 Sign Post (2 inch round)	LF	100	12	112	\$9.00	\$108.00	614 Sign Panel (Class I)	SF	350	8	358	\$13.00	\$104.00	TOTAL ESTIMATED INCREASED COST TO PROJECT						\$30,142.00
<u>ITEM DESCRIPTION</u>	<u>UNIT</u>	<u>PREVIOUS QUANTITY</u>	<u>ADDED QUANTITY</u>	<u>REV. PLAN QUANTITY</u>	<u>UNIT PRICE</u>	<u>INCR. COST TO PROJECT</u>																																																																												
<u>ADD:</u>																																																																																		
203 Unclassified Excavation (CIP)	CY	0	2000	2000	\$10.00	\$20,000.00																																																																												
900 Mechanical Broom	HR	0	4	4	\$45.00	\$180.00																																																																												
900 Remove and Replace Concrete	SY	0	225	225	\$36.00	\$8,100.00																																																																												
900 Additional Overhead	LS	0	1	1	\$1,600.00	\$1,600.00																																																																												
<u>INCREASE:</u>																																																																																		
202 Removal of Ground Sign	EA	25	1	26	\$50.00	\$50.00																																																																												
614 Sign Post (2 inch round)	LF	100	12	112	\$9.00	\$108.00																																																																												
614 Sign Panel (Class I)	SF	350	8	358	\$13.00	\$104.00																																																																												
TOTAL ESTIMATED INCREASED COST TO PROJECT						\$30,142.00																																																																												
The Contractor accepts this Change Order for work to be performed and prices on which payment is to be based.																																																																																		
REQUIRED IN ACCORDANCE WITH INSTRUCTIONS IN THE CDOT CONSTRUCTION MANUAL			REQUIRED FOR ALL CHANGE ORDERS																																																																															
Approved by FHWA Operations Engineer:		Date:	Authorized by Project Engineer:		Date:																																																																													
OPTIONAL			Contractor Representative:		Date:																																																																													
Approved by Region Transportation Director:		Date:	Approved by Resident Engineer:		Date:																																																																													
			<input type="checkbox"/> Participating <input type="checkbox"/> Non-participating <input type="checkbox"/> Participation as noted Approved Funding by Region Program Engineer: _____ Date: _____																																																																															

CDOT Form 90 07/02

Change Fence (ROW Agreement)

MEMORANDUM

DEPARTMENT OF TRANSPORTATION

4201 E. Arkansas Avenue
Denver, Colorado 80222
Phone 303-757-9011



DATE: October 16, 2013 RE: 11111 / NH 66-063
Route 66 - East

TO: (Resident Engineer or Program Engineer as per Region requirements)

FROM: (Project Engineer)

SUBJECT: Contract Modification Order #11, Right-of-Way Agreement-Fence Change

The Right-of-Way Agreement with the owners of Parcel 46 required that Fence Combination Wire be placed between Right-of-Way Point 165 and Right-of-Way Point 166. The plans called for Fence Barbed Wire to be placed in this location. This change order authorizes the Contractor to install Fence Combination Wire instead of Barbed Wire.

Payment for Fence Combination Wire will be at the negotiated price of \$6.00/linear foot for 500 linear feet. This is reasonable when compared to the average bid price of \$5.90/linear foot from the 2000 Cost Data Book for similar quantities.

This change does not impact the critical path; therefore no additional time is required.

The projected cost for this project including this change order is \$1,650,000.00 or 0.4 percent under the current allotment as shown on the attached Project Financial Statement. The budget summary is as follows:

Current Project Budget	\$1,656,459.00	
Projected Costs to Completion	<u>\$1,650,000.00</u>	
Projected Surplus (Deficit)	\$6,459.00	0.4%

A budget action will not be required for this change.

The Contractor has been directed by Form 105 to begin this work. A copy of the completed Form 105 is attached.

This change order was discussed with Rock Howell, Region Program Engineer and with Kevin McGhee, Project Development Area Engineer, on September 30, 2013.

Appendix C

Change Fence (ROW Agreement)

COLORADO DEPARTMENT OF TRANSPORTATION CONTRACT MODIFICATION ORDER	Project No.: NH 66-066	Project Code (SA#): 11111
	Location: Route 66-South	
	Date: September 30, 2013	Project Order No.: 11
Contractor: Good Aim Construction		Estimated cost to project: <input checked="" type="checkbox"/> Increase <input type="checkbox"/> Decrease \$250.00
Complete Address: 14555 Lost Road Aurora, CO 80011		Total additional days allowed to complete work: 0
Modification Title: ROW Agreement-Fence Change		Federal Oversight? <input checked="" type="checkbox"/> Yes <input type="checkbox"/> No

Your Contract is hereby modified to include Fence Combination Wire between Right-of-Way Point 165 and Right-of-Way Point 166.

The Contractor's signature below indicates acceptance of full settlement for the work described, both direct and indirect costs. Any claims for additional impact costs associated with this change will not be considered.

No additional time will be allowed for this work.

The items affected by this change order are as follows:

<u>ITEM DESCRIPTION</u>	<u>UNIT</u>	<u>PREVIOUS QUANTITY</u>	<u>ADDED QUANTITY</u>	<u>REV. PLAN QUANTITY</u>	<u>UNIT PRICE</u>	<u>INCR. COST TO PROJECT</u>
<u>ADD:</u>						
607 Fence Comb Wire w/ Metal Posts	LF	0	500	500	\$6.00	\$3,000.00
<u>DECREASE:</u>						
607 Fence Barbed Wire w/ Metal Posts	LF	5000	-500	4500	\$5.50	(\$2,750.00)
TOTAL ESTIMATED INCREASED COST TO PROJECT						\$250.00

The Contractor accepts this Change Order for work to be performed and prices on which payment is to be based.

REQUIRED IN ACCORDANCE WITH INSTRUCTIONS IN THE CDOT CONSTRUCTION MANUAL		REQUIRED FOR ALL CHANGE ORDERS	
Approved by FHWA Operations Engineer:	Date:	Authorized by Project Engineer:	Date:
OPTIONAL		Contractor Representative:	Date:
		Approved by Resident Engineer:	Date:
Approved by Region Transportation Director:	Date:	<input type="checkbox"/> Participating <input type="checkbox"/> Non-participating <input type="checkbox"/> Participation as noted Approved Funding by Region Program Engineer:	
			Date:

CDOT Form 90 07/02

Utility Work (Utility Invoices Contractor)

MEMORANDUM

DEPARTMENT OF TRANSPORTATION

4201 E. Arkansas Avenue
Denver, Colorado 80222
Phone 303-757-9011



DATE: October 16, 2013 RE: 11111 / NH 66-063
Route 66 - East

TO: (Resident Engineer or Program Engineer as per Region requirements)

FROM: (Project Resident Engineer)

SUBJECT: Contract Modification Order #12, Relocate 24-inch Water Line (Utility Adjusted)

This change order authorizes the Contractor to pay the City of Ft. Morgan to relocate their 24-inch water line. The line is located between Station 486+15 and Station 584+00; 9.5 feet left of the proposed centerline, and 2 feet above finished grade. CDOT was unaware of this line until the City pointed out the location at the Preconstruction Conference. The Region Utilities Engineer was contacted, and she determined that the work is eligible for reimbursement.

The City has provided an estimate for this work of \$490,000. A copy of this estimate is attached.

Fifteen days of additional time will be required for this work. It will take the City five days to obtain the materials and ten days to install and test the water line.

Payment will be made upon the basis of certified invoice from the Utility to the Contractor. The Utility invoice will be the actual direct and indirect cost of performing the work in accordance with established accounting procedures. Administrative compensation will be permitted per subsection 109.04 of the *Standard Specifications*.

The projected cost for this project including this change order is \$5,355,218.00 or 10.1 percent over the current allotment as shown on the attached Project Financial Statement. The budget summary is as follows:

Current Project Budget	\$4,865,218.00	
Projected Costs to Completion	<u>\$5,355,218.00</u>	
Projected Surplus (Deficit)	(\$490,000.00)	10.1%

Need to submit Form 1186.

In order not to delay the project, the Contractor has been directed by Form 105 to begin this work. A copy of the completed Form 105 is attached.

This change order was discussed with Rock Howell, Region Program Engineer and with Don Radel, Project Development Area Engineer, on September 30, 2013.

Appendix C

Utility Work (Utility Invoices Contractor)

COLORADO DEPARTMENT OF TRANSPORTATION CONTRACT MODIFICATION ORDER		Project No.: NH 66-066	Project Code (SA#): 11111																													
		Location: Route 66-South																														
		Date: October 16, 2013	Project Order No.: 12																													
Contractor: Good Aim Construction		Estimated cost to project: <input checked="" type="checkbox"/> Increase <input type="checkbox"/> Decrease \$490,000.00																														
Complete Address: 14555 Lost Road Aurora, CO 80011		Total additional days allowed to complete work: 15	Federal Oversight? <input checked="" type="checkbox"/> Yes <input type="checkbox"/> No																													
Modification Title: Relocate 24-inch Water Line (Utility Adjusted)																																
<p>Your Contract is hereby modified to include the relocation of the 24-inch water line between Station 486+15 and Station 584+00. The City of Ft. Morgan will perform this work. The City will submit certified invoices to the Contractor for payment. These invoices shall be the actual direct and related indirect costs of performing the work in accordance with established accounting procedures. CDOT will reimburse the Contractor by force account for the certified invoices plus administrative loading per subsection 109.04 of the <i>Standard Specifications</i>.</p> <p>The Contractor will provide additional bonding to cover the cost of this work at no cost to the project.</p> <p>Fifteen days will be added for this work.</p> <p>The items affected by this change order are as follows:</p> <table style="width: 100%; border-collapse: collapse;"> <thead> <tr> <th style="text-align: left;"><u>ITEM DESCRIPTION</u></th> <th style="text-align: center;"><u>UNIT</u></th> <th style="text-align: center;"><u>PREVIOUS QUANTITY</u></th> <th style="text-align: center;"><u>ADDED QUANTITY</u></th> <th style="text-align: center;"><u>REV. PLAN QUANTITY</u></th> <th style="text-align: center;"><u>UNIT PRICE</u></th> <th style="text-align: center;"><u>INCR. COST TO PROJECT</u></th> </tr> </thead> <tbody> <tr> <td colspan="7"><u>ADD:</u></td> </tr> <tr> <td>900 Relocate Water Line</td> <td style="text-align: center;">FA</td> <td style="text-align: center;">0</td> <td style="text-align: center;">490,000</td> <td style="text-align: center;">490,000</td> <td style="text-align: center;">\$1.00</td> <td style="text-align: center;">\$490,000.00</td> </tr> <tr> <td colspan="6" style="text-align: right;">TOTAL ESTIMATED INCREASED COST TO PROJECT</td> <td style="text-align: center;">\$490,000.00</td> </tr> </tbody> </table>					<u>ITEM DESCRIPTION</u>	<u>UNIT</u>	<u>PREVIOUS QUANTITY</u>	<u>ADDED QUANTITY</u>	<u>REV. PLAN QUANTITY</u>	<u>UNIT PRICE</u>	<u>INCR. COST TO PROJECT</u>	<u>ADD:</u>							900 Relocate Water Line	FA	0	490,000	490,000	\$1.00	\$490,000.00	TOTAL ESTIMATED INCREASED COST TO PROJECT						\$490,000.00
<u>ITEM DESCRIPTION</u>	<u>UNIT</u>	<u>PREVIOUS QUANTITY</u>	<u>ADDED QUANTITY</u>	<u>REV. PLAN QUANTITY</u>	<u>UNIT PRICE</u>	<u>INCR. COST TO PROJECT</u>																										
<u>ADD:</u>																																
900 Relocate Water Line	FA	0	490,000	490,000	\$1.00	\$490,000.00																										
TOTAL ESTIMATED INCREASED COST TO PROJECT						\$490,000.00																										
The Contractor accepts this Change Order for work to be performed and prices on which payment is to be based.																																
REQUIRED IN ACCORDANCE WITH INSTRUCTIONS IN THE CDOT CONSTRUCTION MANUAL		REQUIRED FOR ALL CHANGE ORDERS																														
Approved by FHWA Operations Engineer:	Date:	Authorized by Project Engineer:	Date:																													
OPTIONAL		Contractor Representative:	Date:																													
Approved by Region Transportation Director:	Date:	Approved by Resident Engineer:	Date:																													
		<input type="checkbox"/> Participating <input type="checkbox"/> Non-participating <input type="checkbox"/> Participation as noted																														
		Approved Funding by Region Program Engineer:	Date:																													

CDOT Form 90 07/02

Utility Work (Contractor Performs Work)

MEMORANDUM

DEPARTMENT OF TRANSPORTATION

4201 E. Arkansas Avenue
Denver, Colorado 80222
Phone 303-757-9011



DATE: October 16, 2013 RE: 11111 / NH 66-063
Route 66 - East

TO: (Resident Engineer or Program Engineer as per Region requirements)

FROM: (Project Resident Engineer)

SUBJECT: Contract Modification Order #12, Relocate 24-inch Water Line (Contractor Adjusted)

This change order authorizes the Contractor to relocate a 24-inch water line owned by the City of Ft. Morgan. The line is located between Station 486+15 and Station 584+00; 9.5 feet left of the proposed centerline, and 2 feet above finished grade. CDOT was unaware of this line until the City pointed out the location at the Preconstruction Conference. The Region Utilities Engineer has determined that the work is eligible for reimbursement.

The Region Utilities Engineer has also obtained a Contractor-Adjusted Utility Agreement with the City of Ft. Morgan to cover this work.

Payment will be made based on the negotiated unit price of \$50.00/linear foot for approximately 9785 linear feet. This is reasonable when compared to the average bid price of \$55.00/linear foot from the 2000 Cost Data Book for similar quantities.

Fifteen days of additional time will be required for this work. It will take the Contractor five days to obtain the materials and ten days to install and test the water line. The Contractor will be compensated \$15,000.00/lump sum for additional overhead. This includes additional costs for Superintendent, trailer rental, phones, gas, fax machine, drinking water, and other miscellaneous items as listed on the attached justification from the Contractor.

The projected cost for this project including this change order is \$5,065,218.00 or 4.1 percent over the current allotment as shown on the attached Project Financial Statement. The budget summary is as follows:

Current Project Budget	\$4,865,218.00	
Projected Costs to Completion	<u>\$5,065,218.00</u>	
Projected Surplus (Deficit)	(\$200,000.00)	4.1%

Need to submit Form 1186.

In order not to delay the project, the Contractor has been directed by Form 105 to begin this work. A copy of the completed Form 105 is attached.

This change order was discussed with Rock Howell, Region Program Engineer and with Don Radel, Project Development Area Engineer, on September 30, 2013.

Appendix C

Utility Work (Contractor Performs Work)

COLORADO DEPARTMENT OF TRANSPORTATION CONTRACT MODIFICATION ORDER		Project No.: NH 66-066	Project Code (SA#): 11111																																				
		Location: Route 66-South																																					
		Date: October 16, 2013	Project Order No.: 12																																				
Contractor: Good Aim Construction		Estimated cost to project: <input checked="" type="checkbox"/> Increase <input type="checkbox"/> Decrease \$504,250.00																																					
Complete Address: 14555 Lost Road Aurora, CO 80011		Total additional days allowed to complete work: 15	Federal Oversight? <input checked="" type="checkbox"/> Yes <input type="checkbox"/> No																																				
Modification Title: Relocate 24-inch Water Line (Contractor Adjusted)																																							
<p>Your Contract is hereby modified to include the relocation of the 24-inch water line between Station 486+15 and Station 584+00. The Contractor will provide additional bonding to cover the cost of this work at no cost to the project.</p> <p>Fifteen days will be added for this work. The Contractor will be compensated \$15,000.00 lump sum for additional overhead. This includes additional costs for Superintendent, trailer rental, phones, gas, fax machine, drinking water, and other miscellaneous items as listed on the attached justification from the Contractor.</p> <p>The items affected by this change order are as follows:</p> <table style="width: 100%; border-collapse: collapse;"> <thead> <tr> <th style="text-align: left;">ITEM DESCRIPTION</th> <th style="text-align: center;">UNIT</th> <th style="text-align: center;">PREVIOUS QUANTITY</th> <th style="text-align: center;">ADDED QUANTITY</th> <th style="text-align: center;">REV. PLAN QUANTITY</th> <th style="text-align: center;">UNIT PRICE</th> <th style="text-align: center;">INCR. COST TO PROJECT</th> </tr> </thead> <tbody> <tr> <td colspan="7">ADD:</td> </tr> <tr> <td>900 Relocate Water Line</td> <td style="text-align: center;">LF</td> <td style="text-align: center;">0</td> <td style="text-align: center;">9785</td> <td style="text-align: center;">9785</td> <td style="text-align: center;">\$50.00</td> <td style="text-align: center;">\$489,250.00</td> </tr> <tr> <td>900 Additional Overhead</td> <td style="text-align: center;">LS</td> <td style="text-align: center;">0</td> <td style="text-align: center;">1</td> <td style="text-align: center;">1</td> <td style="text-align: center;">\$15,000.00</td> <td style="text-align: center;">\$15,000.00</td> </tr> <tr> <td colspan="6" style="text-align: right;">TOTAL ESTIMATED INCREASED COST TO PROJECT</td> <td style="text-align: center;">\$504,250.00</td> </tr> </tbody> </table>					ITEM DESCRIPTION	UNIT	PREVIOUS QUANTITY	ADDED QUANTITY	REV. PLAN QUANTITY	UNIT PRICE	INCR. COST TO PROJECT	ADD:							900 Relocate Water Line	LF	0	9785	9785	\$50.00	\$489,250.00	900 Additional Overhead	LS	0	1	1	\$15,000.00	\$15,000.00	TOTAL ESTIMATED INCREASED COST TO PROJECT						\$504,250.00
ITEM DESCRIPTION	UNIT	PREVIOUS QUANTITY	ADDED QUANTITY	REV. PLAN QUANTITY	UNIT PRICE	INCR. COST TO PROJECT																																	
ADD:																																							
900 Relocate Water Line	LF	0	9785	9785	\$50.00	\$489,250.00																																	
900 Additional Overhead	LS	0	1	1	\$15,000.00	\$15,000.00																																	
TOTAL ESTIMATED INCREASED COST TO PROJECT						\$504,250.00																																	
The Contractor accepts this Change Order for work to be performed and prices on which payment is to be based.																																							
REQUIRED IN ACCORDANCE WITH INSTRUCTIONS IN THE CDOT CONSTRUCTION MANUAL		REQUIRED FOR ALL CHANGE ORDERS																																					
Approved by FHWA Operations Engineer:	Date:	Authorized by Project Engineer:		Date:																																			
OPTIONAL		Contractor Representative:		Date:																																			
Approved by Region Transportation Director:	Date:	Approved by Resident Engineer:		Date:																																			
		<input type="checkbox"/> Participating <input type="checkbox"/> Non-participating <input type="checkbox"/> Participation as noted																																					
		Approved Funding by Region Program Engineer:		Date:																																			

CDOT Form 90 07/02

Traffic Control Plan Change

MEMORANDUM

DEPARTMENT OF TRANSPORTATION

4201 E. Arkansas Avenue
Denver, Colorado 80222
Phone 303-757-9011



DATE: July 25, 2013 Re: 11111/NH 66-066
Route 66-South

TO: (Resident Engineer or Program Engineer as per Region requirements)

FROM: (Project Engineer)

SUBJECT: Contract Modification Order #14, Traffic Control Plan Change

This change order is written to authorize a major revision to the Traffic Control Plan.

The Contractor has proposed constructing a temporary box structure to allow haul trucks to pass under the roadway from the cut area to the fill area. Specifications for this project limit the time the Contractor may interfere with traffic between the hours of 8:30 AM and 4:00 PM. The boxes will reduce impacts to the traveling public and allow the Contractor to work longer hours.

The structure will be erected at Station 582+00, 40 feet left of the existing traffic alignment. After backfilling, a detour will be constructed over this box. The existing pavement and embankment at the box outlet will be excavated to allow the trucks to pass through. Traffic will be maintained on this added detour for the duration of Phase I. Upon completion of the hauling operation, the structure will be removed and the excavation will be backfilled in accordance with the *Project Special Provisions*.

A licensed engineer in the State of Colorado designed the structure for the Contractor.

The proposed alignment and traffic control plan changes have been reviewed and are acceptable, as revised, for the posted speed of this road. The changes have been attached.

All costs associated with this change shall be the responsibility of the Contractor.

There will be no additional time or cost due to this change.

The projected final cost for this project, including this change order, is \$13,445,007.38 or 0.3 percent over the current allotment as shown on the attached Project Financial Statement. The budget summary is as follows:

Current Project Budget	\$13,400,000.00	
Projected Costs to Completion	<u>\$13,445,007.38</u>	
Projected Surplus (Deficit)	(\$45,007.38)	(0.3%)

The Contractor will not begin work on this change until receiving an approved Form 90.

This change order was discussed with Abby Butment, Staff Bridge Engineer on July 2, 2013. This change order was discussed with the Jimmy Cero, Project Development Area Engineer on July 4, 2013. Concurrence was obtained from Rob Crawford, Project Manager, Matt Bemelen, Region Traffic Engineer, and John Cheney, Region Program Engineer on July 2, 2013.

Appendix C

Traffic Control Plan Change

COLORADO DEPARTMENT OF TRANSPORTATION CONTRACT MODIFICATION ORDER	Project No.: NH 66-066	Project Code (SA#): 11111
	Location: Route 66-South	
	Date: July 25, 2013	Project Order No.: 14
Contractor: Good Aim Construction	Estimated cost to project: <input type="checkbox"/> Increase <input type="checkbox"/> Decrease \$0.00	
Complete Address: 14555 Lost Road Aurora, CO 80011	Total additional days allowed to complete work: 0	Federal Oversight? <input checked="" type="checkbox"/> Yes <input type="checkbox"/> No
Modification Title: Traffic Control Plan Change		
<p>You are hereby authorized to make a major revision in the Traffic Control Plan for this project. The Traffic Control Plan as revised will be in accordance with your approved Method of Handling Traffic (attached). The revised Traffic Control Plan will be implemented to accommodate a more efficient method of hauling excavated material from the cut area to the fill area. Instead of hauling across the road, the Contractor will be permitted to construct a temporary structure and associated detour to facilitate hauling under the road.</p> <p>The structure will be constructed at Station 582+00, 40 feet left of existing centerline. After backfilling, a detour shall be constructed over this box. The existing pavement and embankment at the box outlet will be excavated to allow the trucks to pass through. Upon completion of the hauling operation, the Contractor shall backfill the excavation in accordance with the <i>Project Special Provisions</i>.</p> <p>A licensed engineer in the State of Colorado shall design the structure for the Contractor.</p> <p>No additional time will be allowed for this change. All costs associated with this change are the responsibility of the Contractor.</p>		
The Contractor accepts this Change Order for work to be performed and prices on which payment is to be based.		
REQUIRED IN ACCORDANCE WITH INSTRUCTIONS IN THE CDOT CONSTRUCTION MANUAL		REQUIRED FOR ALL CHANGE ORDERS
Approved by FHWA Operations Engineer:	Date:	Authorized by Project Engineer:
		Date:
OPTIONAL		Contractor Representative:
Approved by Region Transportation Director:	Date:	Date:
		Approved by Resident Engineer:
		Date:
		<input type="checkbox"/> Participating <input type="checkbox"/> Non-participating <input type="checkbox"/> Participation as noted
		Approved Funding by Region Program Engineer:
		Date:

CDOT Form 90 07/02

Price Reduction (Accept Out of Spec HBP)

MEMORANDUM

DEPARTMENT OF TRANSPORTATION

4201 E. Arkansas Avenue
Denver, Colorado 80222
Phone 303-757-9011



DATE: October 30, 2013 RE: 11111 / NH 66-063
Route 66 - East

TO: (Resident Engineer or Program Engineer as per Region requirements)

FROM: (Project Engineer)

SUBJECT: Contract Modification Order #10, Acceptance and Price Reduction of Hot Bituminous Pavement

This change order authorizes the Contractor to leave 1800 tons of Hot Bituminous Pavement placed between Station 40+00 and Station 51+00 right in place at a price reduction. A price reduction equal to 28.5 percent of the unit bid price will be applied to this quantity of Hot Bituminous Pavement.

The composite Pay Factor for density, gradation, and asphalt content was 0.90. This is within the specification requirements of subsection 105.03. The Lottman test result representing this quantity of Hot Bituminous Pavement was a 55, which is less than the minimum requirement of 70. The price reduction for the failing Lottman, as calculated in accordance with subsection 105.03, is 28.5 percent.

Normally, a 28.5 percent price reduction would require the removal and replacement of the out of specification material. With the concurrence of the Region Materials Engineer, CDOT has decided to allow the material to remain in place at the calculated price reduction for the following reasons:

- This Hot Bituminous Pavement is part of a detour transition alignment that will be removed as part of a future corridor project.
- The composite pay factor for density, gradation, and asphalt content was acceptable.
- The Hot Bituminous Pavement has been in place for three weeks and has been subjected to high traffic volumes. No pavement degradation is evident.

No additional time is required for this change.

The projected cost for this project including this change order is \$1,650,000.00 or 0.4 percent under the current allotment as shown on the attached Project Financial Statement. The budget summary is as follows:

Current Project Budget	\$1,656,459.00	
Projected Costs to Completion	<u>\$1,650,000.00</u>	
Projected Surplus (Deficit)	\$6,459.00	0.4%

A budget action will not be required for this change.

This change order was discussed with Rock Howell, Region Program Engineer and with Gary LaForce, Project Development Area Engineer, on October 25, 2013.

Appendix C

Price Reduction (Accept Out of Spec HBP)

COLORADO DEPARTMENT OF TRANSPORTATION CONTRACT MODIFICATION ORDER		Project No.: NH 66-066	Project Code (SA#): 11111																												
		Location: Route 66-South																													
		Date: October 30, 2013	Project Order No.: 10																												
Contractor: Good Aim Construction		Estimated cost to project: <input type="checkbox"/> Increase <input checked="" type="checkbox"/> Decrease \$20,520.00																													
Complete Address: 14555 Lost Road Aurora, CO 80011		Total additional days allowed to complete work: 0	Federal Oversight? <input checked="" type="checkbox"/> Yes <input type="checkbox"/> No																												
Modification Title: Acceptance and Price Reduction for Hot Bituminous Pavement																															
<p>Your contract is hereby modified to include a 28.5 percent price reduction for 1800 tons of Hot Bituminous Pavement placed between Station 40+00 and Station 51+00 right. A 28.5 percent price reduction is equivalent to a price reduction of \$11.40/ton. CDOT will allow the Hot Bituminous Pavement to remain in place.</p> <p>No time will be added for this change.</p> <p>The items affected by this change order are as follows:</p> <table style="width: 100%; border-collapse: collapse;"> <thead> <tr> <th style="text-align: left;"><u>ITEM DESCRIPTION</u></th> <th style="text-align: center;"><u>UNIT</u></th> <th style="text-align: center;"><u>PREVIOUS QUANTITY</u></th> <th style="text-align: center;"><u>ADDED QUANTITY</u></th> <th style="text-align: center;"><u>REV. PLAN QUANTITY</u></th> <th style="text-align: center;"><u>UNIT PRICE</u></th> <th style="text-align: center;"><u>INCR. COST TO PROJECT</u></th> </tr> </thead> <tbody> <tr> <td colspan="7"><u>ADD:</u></td> </tr> <tr> <td>900 Price Reduction for HBP</td> <td style="text-align: center;">TON</td> <td style="text-align: center;">0</td> <td style="text-align: center;">-1800</td> <td style="text-align: center;">-1800</td> <td style="text-align: center;">\$11.40</td> <td style="text-align: center;">(\$20,520.00)</td> </tr> <tr> <td colspan="6" style="text-align: right;">TOTAL ESTIMATED INCREASED COST TO PROJECT</td> <td style="text-align: center;">(\$20,520.00)</td> </tr> </tbody> </table>				<u>ITEM DESCRIPTION</u>	<u>UNIT</u>	<u>PREVIOUS QUANTITY</u>	<u>ADDED QUANTITY</u>	<u>REV. PLAN QUANTITY</u>	<u>UNIT PRICE</u>	<u>INCR. COST TO PROJECT</u>	<u>ADD:</u>							900 Price Reduction for HBP	TON	0	-1800	-1800	\$11.40	(\$20,520.00)	TOTAL ESTIMATED INCREASED COST TO PROJECT						(\$20,520.00)
<u>ITEM DESCRIPTION</u>	<u>UNIT</u>	<u>PREVIOUS QUANTITY</u>	<u>ADDED QUANTITY</u>	<u>REV. PLAN QUANTITY</u>	<u>UNIT PRICE</u>	<u>INCR. COST TO PROJECT</u>																									
<u>ADD:</u>																															
900 Price Reduction for HBP	TON	0	-1800	-1800	\$11.40	(\$20,520.00)																									
TOTAL ESTIMATED INCREASED COST TO PROJECT						(\$20,520.00)																									
The Contractor accepts this Change Order for work to be performed and prices on which payment is to be based.																															
REQUIRED IN ACCORDANCE WITH INSTRUCTIONS IN THE CDOT CONSTRUCTION MANUAL		REQUIRED FOR ALL CHANGE ORDERS																													
Approved by FHWA Operations Engineer:	Date:	Authorized by Project Engineer:	Date:																												
OPTIONAL		Contractor Representative:	Date:																												
Approved by Region Transportation Director:	Date:	Approved by Resident Engineer:	Date:																												
		<input type="checkbox"/> Participating <input type="checkbox"/> Non-participating <input type="checkbox"/> Participation as noted																													
		Approved Funding by Region Program Engineer:	Date:																												

CDOT Form 90 07/02

Purchase of Materials (Unused Seed)

MEMORANDUM

DEPARTMENT OF TRANSPORTATION

4201 E. Arkansas Avenue
Denver, Colorado 80222
Phone 303-757-9011



DATE: November 5, 2013 RE: 11111 / NH 66-063
Route 66 - East

TO: (Resident Engineer or Program Engineer as per Region requirements)

FROM: (Project Engineer)

SUBJECT: Contract Modification Order #16, Purchase of Excess Material

This change order provides for the purchase of Wildflower Seed Mix from the Contractor. Due to a change in the amount of seeding on the project, the Contractor had an excess of 80 pounds of the mix. The Contractor indicated that the supplier would not restock the mix because the germination date had passed and it was of no use to them. The Contractor also had no use for the material. The Region Maintenance Section was contacted and indicated that there was no use for the mix and they didn't want it in the storeroom.

The basis of payment will be the cost of the material plus a handling charge as justified by the attached invoice.

No additional time is required for this change.

The projected cost for this project including this change order is \$1,650,000.00 or 0.4 percent under the current allotment as shown on the attached Project Financial Statement. The budget summary is as follows:

Current Project Budget	\$1,656,459.00	
Projected Costs to Completion	<u>\$1,650,000.00</u>	
Projected Surplus (Deficit)	\$6,459.00	0.4%

A budget action will not be required for this change.

This change order was discussed with Rock Howell, Region Program Engineer and with Hal Ghavan, Project Development Area Engineer, on November 3, 2013.

Appendix C

Purchase of Materials (Unused Seed)

COLORADO DEPARTMENT OF TRANSPORTATION CONTRACT MODIFICATION ORDER	Project No.: NH 66-066	Project Code (SA#): 11111																																					
	Location: Route 66-South																																						
	Date: November 5, 2013	Project Order No.: 16																																					
Contractor: Good Aim Construction																																							
Estimated cost to project: <input checked="" type="checkbox"/> Increase <input type="checkbox"/> Decrease \$1650.00																																							
Complete Address: 14555 Lost Road Aurora, CO 80011		Total additional days allowed to complete work: 0																																					
Modification Title: Purchase of Excess Materials		Federal Oversight? <input checked="" type="checkbox"/> Yes <input type="checkbox"/> No																																					
<p>Your Contract is hereby modified to include a payment for excess Wildflower Seed Mix as shown below:</p> <table style="margin-left: 20px;"> <tr> <td>Material Cost</td> <td>80 pounds x \$20.00/pound</td> <td>= \$1,600.00</td> </tr> <tr> <td>Handling Cost</td> <td></td> <td>= \$ 50.00</td> </tr> <tr> <td></td> <td></td> <td style="border-top: 1px solid black;">\$1,650.00</td> </tr> </table> <p>No additional time will be added for this work.</p> <p>The items affected by this change order are as follows:</p> <table style="width: 100%; border-collapse: collapse;"> <thead> <tr> <th style="text-align: left;"><u>ITEM DESCRIPTION</u></th> <th style="text-align: center;"><u>UNIT</u></th> <th style="text-align: center;"><u>PREVIOUS QUANTITY</u></th> <th style="text-align: center;"><u>ADDED QUANTITY</u></th> <th style="text-align: center;"><u>REV. PLAN QUANTITY</u></th> <th style="text-align: center;"><u>UNIT PRICE</u></th> <th style="text-align: center;"><u>INCR. COST TO PROJECT</u></th> </tr> </thead> <tbody> <tr> <td colspan="7"><u>ADD:</u></td> </tr> <tr> <td>900 Wildflower Seed Purchase</td> <td style="text-align: center;">LS</td> <td style="text-align: center;">0</td> <td style="text-align: center;">1</td> <td style="text-align: center;">1</td> <td style="text-align: right;">\$1,650.00</td> <td style="text-align: right;">\$1,650.00</td> </tr> <tr> <td colspan="6" style="text-align: right;">TOTAL ESTIMATED INCREASED COST TO PROJECT</td> <td style="text-align: right;">\$1,650.00</td> </tr> </tbody> </table>			Material Cost	80 pounds x \$20.00/pound	= \$1,600.00	Handling Cost		= \$ 50.00			\$1,650.00	<u>ITEM DESCRIPTION</u>	<u>UNIT</u>	<u>PREVIOUS QUANTITY</u>	<u>ADDED QUANTITY</u>	<u>REV. PLAN QUANTITY</u>	<u>UNIT PRICE</u>	<u>INCR. COST TO PROJECT</u>	<u>ADD:</u>							900 Wildflower Seed Purchase	LS	0	1	1	\$1,650.00	\$1,650.00	TOTAL ESTIMATED INCREASED COST TO PROJECT						\$1,650.00
Material Cost	80 pounds x \$20.00/pound	= \$1,600.00																																					
Handling Cost		= \$ 50.00																																					
		\$1,650.00																																					
<u>ITEM DESCRIPTION</u>	<u>UNIT</u>	<u>PREVIOUS QUANTITY</u>	<u>ADDED QUANTITY</u>	<u>REV. PLAN QUANTITY</u>	<u>UNIT PRICE</u>	<u>INCR. COST TO PROJECT</u>																																	
<u>ADD:</u>																																							
900 Wildflower Seed Purchase	LS	0	1	1	\$1,650.00	\$1,650.00																																	
TOTAL ESTIMATED INCREASED COST TO PROJECT						\$1,650.00																																	
The Contractor accepts this Change Order for work to be performed and prices on which payment is to be based.																																							
REQUIRED IN ACCORDANCE WITH INSTRUCTIONS IN THE CDOT CONSTRUCTION MANUAL		REQUIRED FOR ALL CHANGE ORDERS																																					
Approved by FHWA Operations Engineer:	Date:	Authorized by Project Engineer:	Date:																																				
OPTIONAL		Contractor Representative:	Date:																																				
Approved by Region Transportation Director:	Date:	Approved by Resident Engineer:	Date:																																				
		<input type="checkbox"/> Participating <input type="checkbox"/> Non-participating <input type="checkbox"/> Participation as noted																																					
		Approved Funding by Region Program Engineer:	Date:																																				

CDOT Form 90 07/02

VECP Change Type of Fence (No Form 90)

MEMORANDUM

DEPARTMENT OF TRANSPORTATION

4201 E. Arkansas Avenue
Denver, Colorado 80222
Phone 303-757-9011



DATE: May 25, 2013 Re: 11111/NH 66-066
Route 66-South

TO: (Resident Engineer or Program Engineer as per Region requirements)

FROM: (Project Engineer)

SUBJECT: Contract Modification Order #3, Sound Fence Value Engineering

This change order authorizes a Value Engineering Proposal to install Fence Carsonite (Sound Barrier)(60 inch) in lieu of Fence Metal (Sound Barrier)(60 inch) between Station 400+00 and Station 405+75 right.

The Value Engineering Proposal has been accepted by the Project Engineer based on the following:

- The change will produce a savings to the Department of \$36,869.00.
- The change will provide a product with equivalent quality and desired appearance.
- The materials used are recycled rubber and plastic. The fence will be easy to maintain and environmentally friendly.

The basis of payment is the negotiated price of \$126.76/linear foot for 575 feet of fence. The Contractor has submitted a cost analysis, which has been reviewed and approved by the Project Engineer. The Value Engineering Proposal and cost analysis are attached.

This change will not impact the critical path of the project; therefore, no additional time will be added.

The projected final cost for this project, including this change order, is \$12,193,128.79 or 0.5 percent under the current allotment as shown on the attached Project Financial Statement. No budget action is required. The budget summary is as follows:

Current Project Budget	\$12,254,290.43	
Projected Costs to Completion	<u>\$12,193,128.79</u>	
Projected Surplus (Deficit)	\$61,161.64	(0.5%)

This work has been authorized to proceed in order not to delay the project.

This change order was discussed with the Jimmy Cero, Project Development Area Engineer on July 4, 2013. Concurrence was obtained from Rob Crawford, Project Manager and John Cheney, Region Program Engineer on July 2, 2013.

Appendix C

VECP Change Type of Fence (No Form 90)

COLORADO DEPARTMENT OF TRANSPORTATION CONTRACT MODIFICATION ORDER		Project No.: NH 66-063	Project Code (SA#): 11111																																																		
		Location: Route 66 - East																																																			
		Date: May 25, 2013	Project Order No.: 3																																																		
Contractor: Good Aim Construction		Estimated cost to project: <input type="checkbox"/> Increase <input checked="" type="checkbox"/> Decrease (\$36,869.00)																																																			
Complete Address: 1455 Lost Road Aurora, CO 80011		Total additional days allowed to complete work: 0	Federal Oversight? <input checked="" type="checkbox"/> Yes <input type="checkbox"/> No																																																		
Modification Title: Sound Fence Value Engineering																																																					
<p>Your Contract is hereby modified to change the Fence Metal (Sound Barrier)(60 inch) to Fence Carsonite (Sound Barrier)(60 inch) in accordance with your Value Engineering Proposal. This change affects the materials only. All other specifications pertaining to the sound barrier will remain the same.</p> <p>The items affected by this change are as follows:</p> <table border="1" style="width: 100%; border-collapse: collapse; margin-top: 10px;"> <thead> <tr> <th style="text-align: left;">ITEM DESCRIPTION</th> <th style="text-align: center;">UNIT</th> <th style="text-align: center;">PREVIOUS QUANTITY</th> <th style="text-align: center;">ADDED QUANTITY</th> <th style="text-align: center;">REV. PLAN QUANTITY</th> <th style="text-align: center;">UNIT PRICE</th> <th style="text-align: center;">INCR. COST TO PROJECT</th> </tr> </thead> <tbody> <tr> <td colspan="7">DELETE:</td> </tr> <tr> <td>607 Fence Metal(Sound Barrier)(60 inch)</td> <td style="text-align: center;">LF</td> <td style="text-align: center;">575</td> <td style="text-align: center;">(575)</td> <td style="text-align: center;">0</td> <td style="text-align: center;">\$255.00</td> <td style="text-align: center;">(\$146,625.00)</td> </tr> <tr> <td colspan="7">ADD:</td> </tr> <tr> <td>900 Fence Carsonite(Sound Barrier)(60 inch)</td> <td style="text-align: center;">LF</td> <td style="text-align: center;">0</td> <td style="text-align: center;">575</td> <td style="text-align: center;">575</td> <td style="text-align: center;">\$126.76</td> <td style="text-align: center;">\$72,887.00</td> </tr> <tr> <td>900 Value Engineering Incentive</td> <td style="text-align: center;">LS</td> <td style="text-align: center;">0</td> <td style="text-align: center;">1</td> <td style="text-align: center;">1</td> <td style="text-align: center;">\$36,869.00</td> <td style="text-align: center;">\$36,869.00</td> </tr> <tr> <td colspan="6" style="text-align: right;">TOTAL ESTIMATED INCREASED COST TO PROJECT</td> <td style="text-align: center;">(\$36,869.00)</td> </tr> </tbody> </table> <p style="margin-top: 10px;">This change does not impact the critical path; therefore, no additional time is required.</p>					ITEM DESCRIPTION	UNIT	PREVIOUS QUANTITY	ADDED QUANTITY	REV. PLAN QUANTITY	UNIT PRICE	INCR. COST TO PROJECT	DELETE:							607 Fence Metal(Sound Barrier)(60 inch)	LF	575	(575)	0	\$255.00	(\$146,625.00)	ADD:							900 Fence Carsonite(Sound Barrier)(60 inch)	LF	0	575	575	\$126.76	\$72,887.00	900 Value Engineering Incentive	LS	0	1	1	\$36,869.00	\$36,869.00	TOTAL ESTIMATED INCREASED COST TO PROJECT						(\$36,869.00)
ITEM DESCRIPTION	UNIT	PREVIOUS QUANTITY	ADDED QUANTITY	REV. PLAN QUANTITY	UNIT PRICE	INCR. COST TO PROJECT																																															
DELETE:																																																					
607 Fence Metal(Sound Barrier)(60 inch)	LF	575	(575)	0	\$255.00	(\$146,625.00)																																															
ADD:																																																					
900 Fence Carsonite(Sound Barrier)(60 inch)	LF	0	575	575	\$126.76	\$72,887.00																																															
900 Value Engineering Incentive	LS	0	1	1	\$36,869.00	\$36,869.00																																															
TOTAL ESTIMATED INCREASED COST TO PROJECT						(\$36,869.00)																																															
The Contractor accepts this Change Order for work to be performed and prices on which payment is to be based.																																																					
REQUIRED IN ACCORDANCE WITH INSTRUCTIONS IN THE CDOT CONSTRUCTION MANUAL		REQUIRED FOR ALL CHANGE ORDERS																																																			
Approved by FHWA Operations Engineer:	Date:	Authorized by Project Engineer:	Date:																																																		
OPTIONAL		Contractor Representative:	Date:																																																		
Approved by Region Transportation Director:	Date:	Approved by Resident Engineer:	Date:																																																		
		<input type="checkbox"/> Participating <input type="checkbox"/> Non-participating <input type="checkbox"/> Participation as noted																																																			
		Approved Funding by Region Program Engineer:	Date:																																																		

MEMORANDUM

DEPARTMENT OF TRANSPORTATION

4201 E. Arkansas Avenue
Denver, Colorado 80222
Phone 303-757-9011



DATE: December 4, 2013 RE: 11111 / NH 66-063
Route 66 - East

TO: (Resident Engineer or Program Engineer as per Region requirements)

FROM: (Project Engineer)

SUBJECT: Minor Contract Revisions

This change order was written to authorize the following minor contract revisions:

LINE ITEM #1) Change Order #3 - ITEM 900-70035 MUCK EXCAVATION

This item was added to compensate the Contractor for Muck Excavation between Station 453+00 and Station 455+00 left. This muck was created by existing drainage problems and was due to no fault of the Contractor. The excavated area is approximately 200 feet by 50 feet by six feet deep.

Due to the difficulty in estimating the cost of this work, the work was performed by force account. The total estimated cost of this item is \$9,000.00. This item is participating.

This item was performed concurrently with other work and did not require additional time.

LINE ITEM #2) Change Order #5 - ITEM 210-01200 RESET END ANCHORAGE

Approximately 463 linear feet of guardrail was removed at Station 414+00 to provide access to a planned fill area. The existing end anchorage had to be reset at the end of the remaining guardrail run. There was no item in the plans to pay for this work.

The basis of payment for this item is the negotiated price of \$522.50/each for one anchor. For similar quantities, the average bid price from the 2000 Cost Data Book varied between \$525.00/each to \$600.00/each. Therefore, the price is reasonable. The total estimated cost of this item is 1 each @ \$552.50/each or \$522.50. This item is participating.

This item was performed concurrently with other work and did not require additional time.

LINE ITEM #3) Change Order #9 - ITEM 412-12320 Portland Cement Concrete Pavement SPECIFICATION CHANGE

This item was added to allow a change to the Portland Cement Concrete Pavement specifications. The change to utilize the most current CDOT specification regarding sawing, sealing, and tining was recommended by the Region Materials Engineer. For all Portland Cement Concrete Pavement on this project, the Contractor shall comply with the attached sawing, sealing, and tining specification.

The Contractor agreed to this change at no cost to the project. This item is participating.

This item was performed concurrently with other work and did not require additional time.

Example of Simple FA Analysis Justification

MCR Line # 14

A vertical displacement was observed in an existing MSE wall at the east abutment of the 28th St. Bridge over I-225, adjacent to a proposed detour. An investigation by Wilber Smyth of Staff Bridge and Eric Hericot of Region 8 Hydraulics determined that the wall had bowed outward due to erosion of backfill material behind the masonry face.

The contractor submitted a lump sum cost of \$15,500.00 to repair the wall. This work includes the removal of block facing, excavation of existing material, followed by the replacement of backfill material and blocks. Concrete slope and ditch paving will be placed to prevent further erosion. The contractor's lump sum price of \$15,500.00 was accepted based on the following analysis. A subcontractor will be doing the work; fringe benefits are included in the rates. Labor rates are Davis-Bacon rates for this contract, equipment rates are from the historical data in Chapter 6 of the QC Training Manual, and material costs were quoted by local suppliers (ABC Concrete and Wilson Precast).

Labor

Laborer (3)	144 hr. x \$25.00/hr.	\$3,600.00	
Operator	48 hr. x \$35.00/hr.	1,680.00	
	67% loading	<u>2,412.00</u>	
	Labor Total	\$8,817.60	\$8,817.60

Equipment

Flatbed Truck	16 hr. @ \$20/hr.	\$ 320.00	\$ 320.00
---------------	-------------------	-----------	-----------

Rental Equipment

Backhoe	6 days @ \$200/day	\$ 1,200.00	
	10% Loading	<u>120.00</u>	
	Rental Equipment Total	\$ 1,320.00	\$ 1,320.00

Materials

Concrete C1 B	14 CY @ \$250.CY	\$3,500.00	
Facing Blocks	100 each @ \$12.00	1,200.00	
	15% loading	<u>705.00</u>	
	Materials Total	\$5,405.00	<u>\$5,405.00</u>

Subtotal			\$15,862.60
Administrative loading per 109.04(e)			<u>725.88</u>

Total \$16,588.48

Therefore, the contractor's submitted price of \$15,500.00 is acceptable.

No additional time will be added to the contract for this work.

CDOT CONSTRUCTION MANUAL

APPENDIX D. MISCELLANEOUS DATA

Appendix D

APPENDIX D. MISCELLANEOUS DATA	D-1
MISCELLANEOUS DATA.....	D-3

MISCELLANEOUS DATA

Appendix D presents common tables, figures, and miscellaneous data that Project Engineers and Project Inspectors will use on a day-to-day basis. These include such items as legal dimensions and weights for trucks, procedures for measuring and documenting vertical and lateral clearances at structures, grade stamps used by accredited lumber inspection agencies, and miscellaneous mathematical formulas.

**Figure 105-1
DISPUTES AND CLAIMS FLOW CHART**

(Note: If an audit is to be performed, durations in this flow chart are extended accordingly)

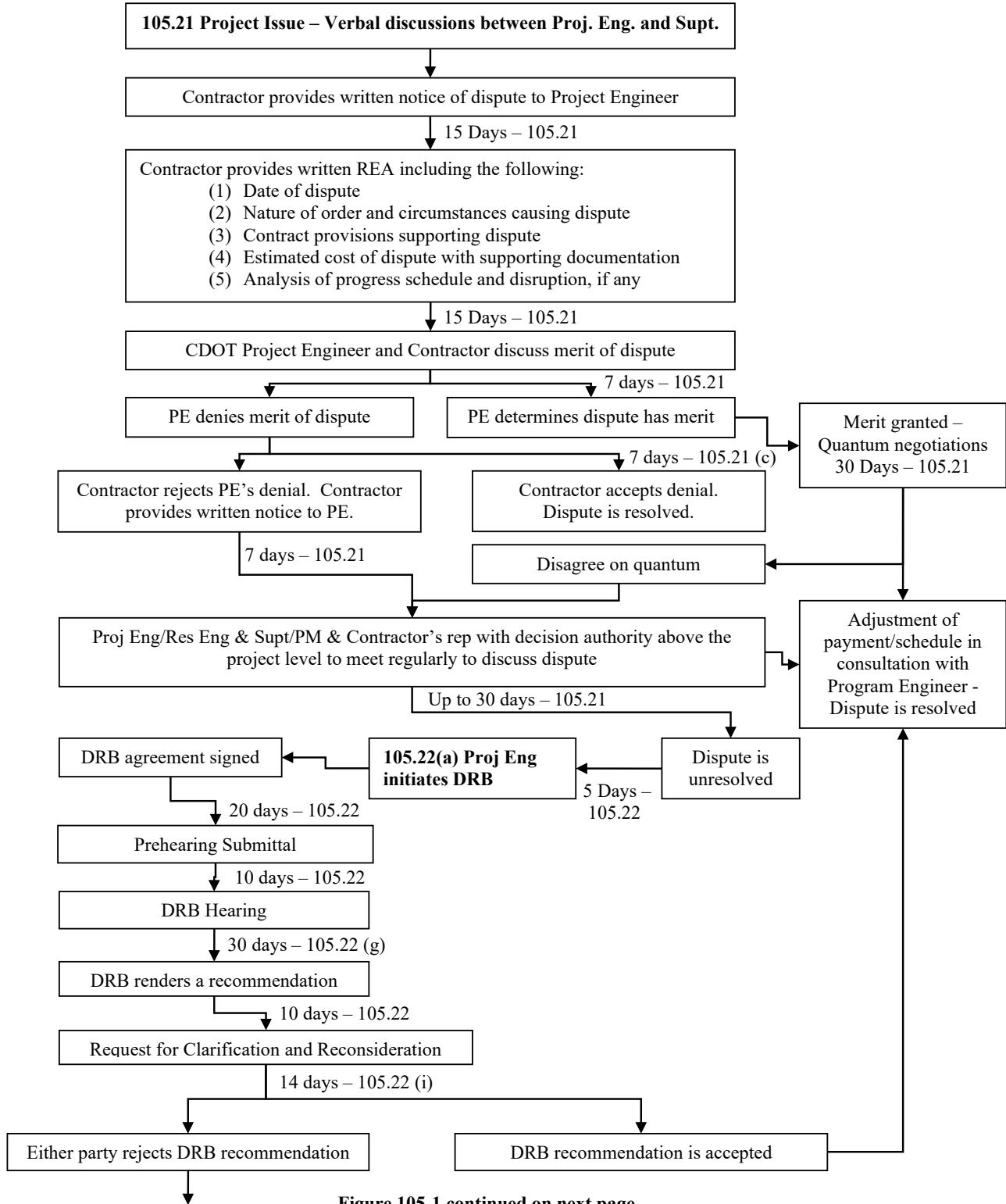
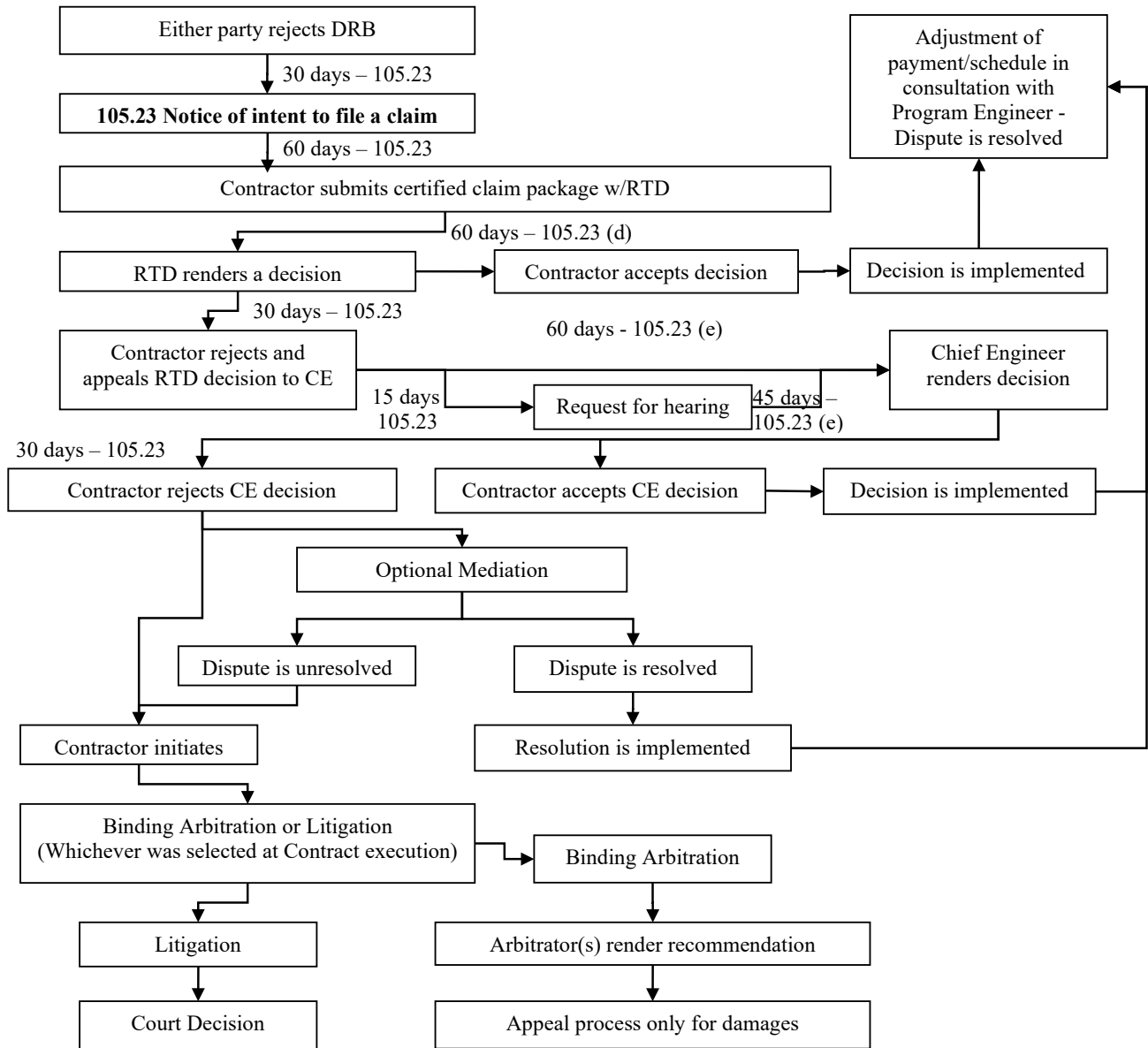

Figure 105-1 continued on next page

Figure 105-1 (continued)



**Colorado Department of Transportation
For Your Information (FYIs)**

LEGAL VEHICLE DIMENSIONS (CDOT FYI 1)

The figures below reflect legal size limitations, any dimensions exceeding these limitations will require an oversize permit **C.R.S. 42-4-510(11)**. The metric equivalents are not part of the statutory references, but are displayed only for informational purposes.

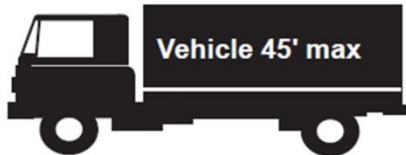

Single unit maximum length is **45' (13.72 meters)** as measured from extreme front bumper to extreme rear bumper. **C.R.S. 42-4-504(2)**



No overall length limit for a combination with a single trailer length of **57' 4" (14.47 meters)** or less in length. **C.R.S. 42-4-504(4)**



No overall length limit for a combination of units with trailers **28'6" (8.68 meters)** or less in length. The common name for this combination is "Western Double". **C.R.S. 42-4-504(4)**



Saddlemounts are allowed **97' (29.57 meters)** in length for no more than **4** total units. A fullmount also may be transported as part of this combination. A fullmount is a smaller vehicle that is mounted completely on the frame of either the first or last vehicle in a saddlemount combination. **C.R.S. 42-4-504(4.5)**

**Colorado Department of Transportation
For Your Information (FYIs)**

15' (4.57 meters) Drawbar



When one vehicle is towing another the drawbar or other connection shall be of sufficient strength to pull all weight towed, and the drawbar or other connection shall not exceed **15 feet (4.57 meters)** from one vehicle to the other **C.R.S. 42-4-506(1)**

Load may not project more than **4 feet (1.22 meters)** from the front most part of the grill.
C.R.S. 42-4-504(5)



Load may not project more than **10 feet (3.05 meters)** to the rear of the vehicle bumper. Overhangs for automobile and boat transporters are restricted to **6 feet (1.83 meters)**. **C.R.S. 42-4-504(6)**

DAYLIGHT TRAVEL - Red flags are required at the end of the load projections greater than **4 feet (1.22 meters)**.
C.R.S. 42-4-209

NIGHT TRAVEL - A red light or lantern is required at the end of the load projections greater than **4 feet (1.22 meters)**. **C.R.S. 42-4-209**

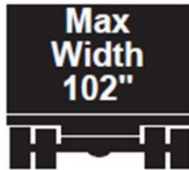

The total outside width of any vehicle or load shall not exceed **102" (2.59 meters)**, excluding mirrors or safety devices. **C.R.S. 42-4-502 (1), (5)**



No vehicle unladen or with load shall exceed a height of **13' (3.96 meters)**; except that vehicles with a height of **14' 6" (4.42 meters)** shall be operated only on highways designated by the State Department of Transportation. **C.R.S. 42-4-504(1)**

PERMIT FEES FOR VEHICLES THAT EXCEED LEGAL VEHICLE LIMITATIONS C.R.S. 42-4-510 (11)

Single Trip Permit	(Oversize)	\$15.00*
	(Special)	\$125.00* required when a load exceeds maximum extra-legal dimensions.
Annual Permit	(Oversize)	\$250.00 per permitted power unit.
Annual Fleet Permit	(Overlength)	This fleet permit only applies to public utility vehicles and loads. \$1,500.00 plus \$15.00 per fleet vehicle.

For detailed information and requirements concerning oversize/overweight permits, please refer to the Department of Transportation's Rules and Regulations titled "Pertaining to Transport Permits for the Movement of Extra-Legal Vehicles or Loads" (2 CCR 601-4). **For more information contact CDOT at (303) 757-9539 or 1-800-350-3765.**

*Effective July 1, 2009 – Single trip and special transport permits will be assessed a surcharge equal to the permit fee.

**Colorado Department of Transportation
For Your Information (FYIs)**

LEGAL VEHICLE WEIGHT LIMITS (CDOT FYI 2)

The figures below reflect legal weight limits **C.R.S. 42-4-508**, any weights exceeding these limitations will require an overweight permit **C.R.S. 42-4-510(11)**. The metric equivalents are not part of the statutory references, but are displayed only for informational purposes.

- A single axle shall not exceed 20,000 pounds (9,072 kg). ❶
- Tandem axles shall not exceed 36,000 pounds (16,330 kg), 40,000 pounds (18,144 kg) non-interstate.

TWO AXLE/SINGLE UNIT



Maximum gross weight allowed on any Non-Interstate Colorado highway is limited to the Colorado Bridge Formula. * ❷

Gross Weight = (Length + 40) x 1,000

C.R.S. 42-4-508 (1)(b)

THREE OR MORE AXLES/SINGLE UNIT



Maximum gross weight allowed on any Interstate highway is limited to the Federal Bridge Formula. * ❷

Gross Weight = 500 (LN/N-1 + 12N + 36)

* Total weight must be distributed so that no single or tandem axle exceeds the maximum gross weight limits allowed on the road where they are weighed.
C.R.S. 42-4-508(1)(c)

NON-INTERSTATE HAULERS



Maximum gross weight allowed on any Colorado non-interstate highway is 85,000 pounds (38,556 kg). ❷

In addition vehicles must comply with the axle weight limitations and the Colorado Bridge Formula.
C.R.S. 42-4-508(1)(b)

Gross Weight = (Length + 40) x 1,000

- ❶ A single axle shall not exceed 21,000 pounds (9,530 kg) for digger-derrick or bucket boom trucks operated by an electric utility on a non-interstate highway. C.R.S. 42-5-507(2)(b.5)
- ❷ Gross weight limits are increased by 1,000 pounds (450 kg) for vehicles or combination of vehicles that contain an alternative fuel system and that operate on alternative fuel and conventional fuel on the non-interstate highways. C.R.S. 42-5-508(1.5)

**Colorado Department of Transportation
For Your Information (FYIs)**

INTERSTATE HAULERS



Maximum gross weight allowed on any Colorado Interstate highway is **80,000 pounds (36,288 kg)**. In addition vehicles traveling on interstate highways must comply with the Federal Bridge Formula. **C.R.S. 42-4-508 (1)(c)**

Gross weight = $500 (LN/N-1 + 12N + 36)$

FEDERAL BRIDGE FORMULA

Gross weight = $500 (LN/N-1 + 12N + 36)$

L = Distance in feet between the extremes of any group of two or more consecutive axles.

N = Number of axles being considered. In computations of this formula no gross vehicle weight shall exceed 80,000 pounds except as may be authorized under [Section 42-4-510\(II\)](#).

PERMIT FEES FOR VEHICLES THAT EXCEED LEGAL WEIGHT LIMITATIONS C.R.S. 42-4-510(11)

Single Trip Permit	Overweight	\$15.00 plus \$5.00 per axle*	
	Non-Interstate Overweight Divisible Load – 2/3 Axle Trailer	\$15.00 plus \$10 per axle*	
	Non-Interstate Overweight Divisible Load – Quad Axle	\$30.00 plus \$10 per axle	
Special	\$125.00* This special permit is for structural, oversized, or overweight moves requiring extraordinary action or moves involving weight in excess of two hundred thousand pounds.		
Annual Permit Overweight	\$400.00 per permitted power unit.		
Annual Non-Interstate Overweight Divisible Load Permit (NIOWD) – for either the 2/3 Axle Trailer or Quad Axle Permit	–	\$500.00	
6-Month Non-Interstate Overweight Divisible Load Permit – for the 2/3 Axle Trailer Permit	–	\$250.00	
Annual Fleet Permit			
LVC Overweight	This fleet permit only applies to Longer Vehicle Combinations as defined in C.R.S. 42-4-505. \$1,500.00 plus \$25.00 per vehicle to be permitted.		
NIOWD Quad	This fleet permit only applies to Non-Interstate Divisible Load permits where the vehicle has a quad-axle configuration. \$2,000 plus \$35.00 per vehicle to be permitted.		

Payment for permits will be accepted as follows:

1. Cash
2. Check
3. Escrow Accounts
4. Visa or MasterCard
5. Cash

For detailed information and requirements concerning overweight/oversize permits, please refer to the Department of Transportation's Rules and Regulations titled "Pertaining to Transport Permits for the Movement of Extra-Legal Vehicles of Loads" (2 CCR 601-4). **For more information contact CDOT at (303) 757-9539 or 1-800-350-3765.**

*Effective July 1, 2009- Single trip and special transport permits will be assessed a surcharge equal to the permit fee.

**Colorado Department of Transportation
For Your Information (FYIs)**

LONGER VEHICLE COMBINATIONS (CDOT FYI 3)

A Longer Vehicle Combination (LVC) (C.R.S. 42-4-505) shall not have more than three cargo units, fewer than six axles nor more than nine axles. The heaviest gross weight shall be hauled in the first semitrailer. LVCs must obtain a special permit and may only travel on designated routes. LVCs, except the "Truck with Trailer" combination, have no overall length limitation. Vehicle weight (GVW) is 80,000 pounds (36,288 kg) unless an overweight permit is purchased. C.R.S. 42-4-510(11) - (The metric equivalents are not part of the statutory references, but are displayed only for informational purposes.)



An unladen truck tractor, one semitrailer which shall not exceed 48' (14.63 meters) and one trailer which shall not exceed 28' 6" (8.68 meters). The shorter trailer shall be operated as the rear trailer. The common name for this combination is "Rocky Mountain Double." C.R.S. 42-4-505 (2)(c)



An unladen truck tractor, one semitrailer and trailer which shall be of approximately equal lengths not to exceed 48' (14.63 meters). This combination may operate with up to eleven axles provided that the trailers are empty. The common name for this combination is "Turnpike Double." C.R.S. 42-4-505 (2)(b)



An unladen truck tractor, one semitrailer and two trailers which shall be of approximately equal lengths not to exceed 28' 6" (8.68 meters). The common name for this combination is "Triple." C.R.S. 42-4-505 (2)(a)



One single unit truck and trailer which shall not exceed 85' (25.91 meters). The truck shall not be more than 35' (10.67 meters) and the trailer not more than 40' (12.19 meters). The common name for this combination is "Truck With Trailer." C.R.S. 42-4-505 (2)(d)

Colorado Department of Transportation For Your Information (FYIs)

DESIGNATED ROUTES

- a) On I-25 from the Colorado-New Mexico state line to the Colorado-Wyoming state line.
- b) On I-70 from the junction of US 40 and SH 26, in Denver, to the Colorado-Kansas state line.
- c) On I-76 from the junction of I-70, in Denver, to the Colorado-Nebraska state line.
- d) On I-270 from the junction of I-70 to the junction of I-76.
- e) On I-225 from the junction of I-25 to the junction of I-70.
- f) On I-70 from the Colorado-Utah state line to the junction of SH 13.
- g) On SH 133, in Delta County, from Milepoint 8.9 to Milepoint 9.7 (Non-Interstate Highway).

HOURS OF OPERATION

A LVC shall not operate on the following designated highway segments during the hours of 7:00 a.m. to 9:00 a.m. and from 4:00 p.m. to 6:00 p.m., Monday through Friday, for Colorado Springs, Denver, and Pueblo. LVCs operating above the legal maximum weight are subject to different hours of operation restrictions. Refer to rules pertaining to Extra-Legal Vehicles or Loads.

Colorado Springs	I-25 from Academy Blvd South to Academy Blvd North
Denver	I-25 from I-225 to SH 128 (120th Ave) I-70 from US 40/SH 26 to I-225 I-76 from I-70 to SH 85 I-225 from I-25 to I-70 I-270 from I-76 to I-70
Pueblo	I-25 from Lake Ave (Exit #94) to SH 47/SH 50 (Exit #101)

INGRESS AND EGRESS

Longer Vehicle Combinations can be permitted to go to the following facilities: **1)** Manufacturing or distribution centers, warehouses, or truck terminals, that are located in an area where industrial uses are permitted; and, **2)** Construction sites. This off-highway-segment travel is limited to a maximum of 10 miles which shall be measured by the most direct travel rather than by the radius from the facility to the designated route. The ingress and egress route(s) between the designated state highway segment and the facility must be approved in advance by the public entity (CDOT, municipality, or county) having jurisdiction for the roadway(s) that make up the route(s).

MAXIMUM WEIGHTS

The legal maximum gross vehicle weight of a longer vehicle combination is 80,000 pounds (36,288 kg), the vehicle shall not exceed 20,000 pounds (9,072 kg) on any single axle or 36,000 pounds (16,330 kg) on any tandem axle and the vehicle must comply with the Federal Bridge Formula. If an overweight permit is purchased, the vehicle must comply with the aforementioned axle weight limitations and the maximum gross vehicle weight shall not exceed the **minimum** of any of the following conditions:

- 1. 110,000 pounds (49,896 kg)
- 2. 800 (L + 40)
- 3. 500 (LN/N-1 + 12N + 36)

For more details see the Department of Transportation's Rules and Regulations titled "Pertaining to Transport Permits for the Movement of Extra-Legal Vehicles or Loads" (2 CCR 601-4). For more information contact CDOT at (303) 757-9539 or 1-800-350-3765.

PERMIT FEES C.R.S.42-4-505(1)

Annual Permit; \$250.00 for each applicant.

For more detailed information and requirements concerning a Longer Vehicle Combination permit, please refer to the Department of Transportation's Rules and Regulations titled "Operation of Longer Vehicle Combinations on Designated State Highway Segments" (2 CCR 601-9). **For more information contact CDOT at (303) 757-9539 or 1-800-350-3765.**

HAZARDOUS MATERIALS

For more detailed information concerning the transportation of hazardous materials on Longer Vehicle Combinations, refer to the Department of Public Safety's Rules and Regulations titled "Hazardous Materials Transportation Permits" (8 CCR 1507-25). **For more information contact CSP at (303) 273-1900.**

Fact Sheet

Non-Interstate Quad Axle Overweight Divisible Permits

Effective October, 2008

- Overweight permits only (no oversize/over dimension)
- Non-interstate highways only
- Vehicle must be configured with a quad axle grouping
- Cannot exceed 110,000 lbs. gross vehicle weight
- Must comply with maximums on CDOT Bridge Weight Limit Map
- Single trip permit available. Fee: \$30 + \$10 per axle
- Annual permit available. Fee: \$500
- Annual Fleet Permit available. Fee: \$2,000 + \$35 per permitted vehicle
- Substantial fines may be assessed for violations

Non-Interstate Tandem/Triple Axle Overweight Divisible Permits

Effective January 1, 2010

- Overweight permits only (no oversize/over dimension)
- Non-interstate highways only
- Applies to tractor/trailer combination vehicles only
- Must have either tandem or triple axle grouping on trailer
- Cannot exceed 97,000 lbs. gross vehicle weight
- Must comply with maximums on CDOT Bridge Weight Limit Map
- Single trip permit available. Fee: \$15 +\$10 per axle, plus a surcharge equal to the total amount of the permit
- Six-month permit available. Fee: \$250
- Annual permit available: Fee: \$500
- Substantial fines may be assessed for violations

To view Legislation click on the respective link:

- Quad Axle Non-Interstate Overweight Divisible Permits – [HB 08-1257](#)
- Tandem/Triple Axle Overweight Divisible Permits – [HB 09-1318](#)

Fact sheet compiled September 16, 2009

Appendix D

PROCEDURE FOR MEASURING AND DOCUMENTING VERTICAL AND LATERAL CLEARANCES FOR BRIDGES AND SIGNS (Applicable to New Construction, Reconstruction, Overlay, and Rehabilitation Projects)

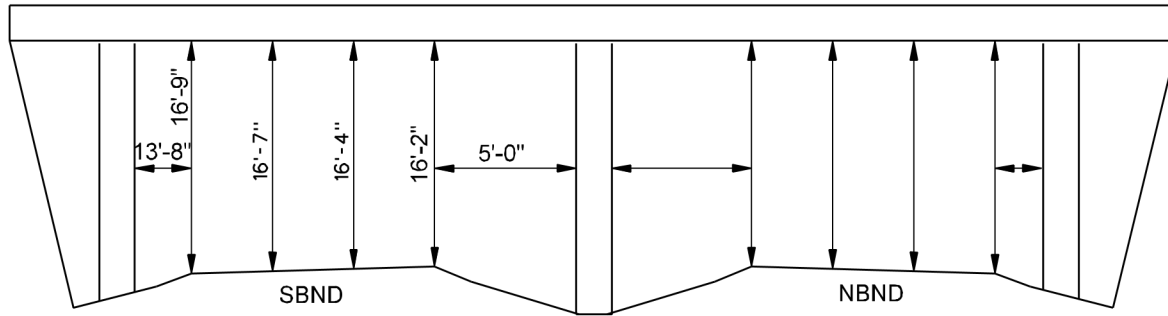

LOOKING N

I-25

EXAMPLE SHOWING 16th ST BRIDGE OVER I-25

Recording Vertical and Lateral Clearances

1. Make an accurate sketch of bridge or sign structure.
2. Take measurements of vertical clearances as shown below. Be sure to measure the clearances under all the girders to determine the minimum along each lane line. Also measure and record lateral clearances.
3. On sign structures, the minimum may not be the sign support. It may be a cat walk or an appurtenance hanging lower.
4. Record the measurements on a sketch of the bridge or sign as shown above.
5. Note which direction you are looking on the sketch. On a divided highway, record measurements for both structures while looking in one direction only. Do not look in the direction of traffic for each of the bridges.
6. Send the information to Bridge Records, c/o Staff Bridge Branch. If less than 16'-6", notify Staff Maintenance - Oversize/Overweight Permits (See Section 630.2.4 and Construction Bulletin, January 20, 2001).

Where to Measure Vertical Clearances

1. Locate the edge of roadway, excluding shoulder. Typically, a solid white line represents the edge of roadway.
2. Locate the lowest point of the structure directly above that line.
3. Measure the clearance.
4. Record the measurement.
5. Repeat steps 2, 3, and 4 for each roadway line.

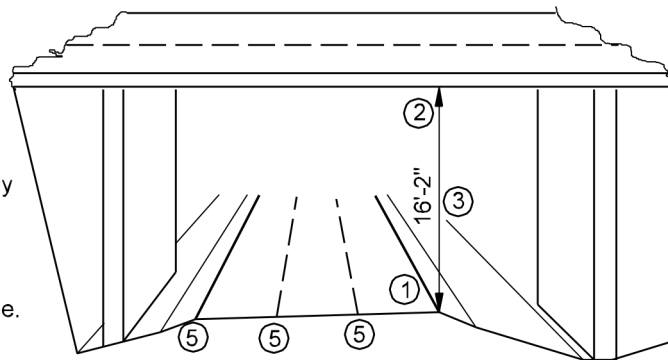

American Lumber Standard Committee, Incorporated

R.K. Caron, Chairman
T.F. Brodie, Vice Chairman
H.B. Sager, Treasurer
T.D. Searles, President

P.O. Box 210
Germantown, Maryland 20875-0210
Telephone: 301.972.1700
Fax: 301.540.8004
E-Mail: alsco@alsco.org

February 2013

(this list supersedes all previous lists)

The following rules have been certified as conforming to the American Softwood Lumber Standard, PS20, by the Board of Review of the American Lumber Standard Committee:

1. **Standard Grading Rules for Northeastern Lumber**; published by the Northeastern Lumber Manufacturers Association (NELMA), 272 Tuttle Road, P.O. Box 87A, Cumberland Center, ME 04021; phone 207.829.6901; fax 207.829.4293
2. **Standard Grading Rules**; published by the Northern Softwood Lumber Bureau (NSLB), 272 Tuttle Road, P.O. Box 87A, Cumberland Center, ME 04021; phone 207.829.6901; fax 207.829.4293
3. **Standard Specifications for Grades of California Redwood Lumber**; published by the Redwood Inspection Service (RIS), 818 Grayson Road, Suite 201, Pleasant Hill, CA 94523-2693; phone 925.935.1499; fax 925.935.1496
4. **Standard Grading Rules for Southern Pine Lumber**; published by the Southern Pine Inspection Bureau (SPIB), 4709 Scenic Highway, Pensacola, FL 32504; phone 850.434.2611; fax 850.433.5594
5. **Standard Grading Rules for West Coast Lumber**; published by the West Coast Lumber Inspection Bureau (WCLIB), Box 23145, Portland, OR 97281-3145; phone 503.639.0651; fax 503.684.8928
6. **Western Lumber Grading Rules**; published by the Western Wood Products Association (WWPA), 522 SW Fifth Avenue, Portland, OR 97204-2122; phone 503.224.3930; fax 503.224.3934
7. **Standard Grading Rules for Canadian Lumber**; published by the National Lumber Grades Authority (NLGA), Suite 105, 13401-108th Avenue, Surrey, BC V3T 5T3; phone 604.584.2393; fax 604.584.2890

Agencies Accredited by the Board of Review of the American Lumber Standard Committee, Incorporated and Typical Grade Stamps.

TYPICAL GRADE STAMP

MILL 000
CONTINENTAL STAND
INSPECTION AGENCY & BTR
DOUG FIR S-GRN

AGENCY NAMES & ADDRESSES

Continental Inspection Agency, LLC (CI)
P.O. Box 785
Lodi, CA 95241

209.367.3840
916.718.5217
fax: 209.367.3840
e-mail: drdodgeman@sbcglobal.net

1. Approval as an inspection agency including mill supervisory services under:
 - a. WWPA rules
 - b. WCLIB rules
 - c. RIS rules
 - d. NGR portion of the NLGA rules
2. Approved to provide heat treatment audit services under all rules.

S-DRY 001
FINISH
 EASTERN
 WHITE PINE



Northeastern Lumber Manufacturers Association (NeLMA)

272 Tuttle Road, P.O. Box 87A
 Cumberland Center, ME 04021

207.829.6901
 fax: 207.829.4293
 e-mail: info@nelma.org

1. NeLMA is a rules writing agency.
2. Approval of rules they publish and as an inspection agency including mill supervisory services under:
 - a. NeLMA rules
 - b. NSLB rules
 - c. NGR, Posts and Timbers, and Beams and Stringers portions of WCLIB rules
 - d. NGR, Selects and Common Boards, 4/4 Shop, Heavy Shop, Posts and Timbers, and Beams and Stringers under the WWPA rules
 - e. NGR portion of the SPIB rules
 - f. NGR portion of the NLGA rules
3. Approved to supervise glued and machine graded lumber.
4. Approved to provide heat treatment audit services under all rules.

S-DRY 001
STAND
 EASTERN
 WHITE PINE **NELMA®**

110 **STUD**
 S-DRY
 BALSAM
 FIR



Northern Softwood Lumber Bureau (NSLB)

272 Tuttle Road, P.O. Box 87A
 Cumberland Center, ME 04021

207.829.6901
 fax: 207.829.4293
 e-mail: info@nelma.org

1. NSLB is a rules writing agency
2. Approval of rules they publish and as an inspection agency including mill supervisory service under:
 - a. NSLB rules
 - b. NGR portion of WCLIB rules
 - c. NGR portion of the WWPA rules
 - d. NGR portion of NLGA rules
3. Approved to supervise glued and machine graded lumber.
4. Approved to provide heat treatment audit services under all rules.

PIB W-10
CONST
 S-GRN
 HEM-FIR WCLB RULES

Pacific Lumber Inspection Bureau (PLIB)

1010 South 336th Street
 Suite 300
 Federal Way, WA 98003

253.835.3344
 fax: 253.835.3371
 e-mail: info@plib.org

1. Approval as an inspection agency including mill supervisory service under:
 - a. WCLIB rules
 - b. WWPA rules
 - c. RIS rules
 - d. NLGA rules
2. Approved to supervise glued and machine graded lumber.
3. Approved to provide heat treatment audit services under all rules.

MILL 001
DECK COM
 S-DRY REDWOOD **RIS**

Redwood Inspection Service (RIS)

818 Grayson Road, Suite 201
 Pleasant Hill, CA 94523-2693

925.935.1499
 fax: 925.935.1496
 e-mail: info@calredwood.org

1. RIS is a rules writing agency.
2. Approval of rules they publish and as an inspection agency including mill supervisory service under:
 - a. RIS rules
 - b. WCLIB rules
 - c. WWPA rules
3. Approval to supervise machine graded lumber.
4. Approved to provide heat treatment audit services under all rules.



Renewable Resource Associates, Inc. (RRA)

860 Johnson Ferry Road
Suite 140-194
Atlanta, GA 30342

678.528.3734 or 770.330.9416
fax: 678.528.8082
e-mail: lon@rrainc.net

1. Approval as an inspection agency including mill supervisory service under:
 - a. SPIB rules
 - b. NGR, Posts and Timbers, and Beams and Stringers portions of the NLGA rules
 - c. NGR, Selects and Finish, Boards, Posts and Timbers, and Beams and Stringers portions of the WHPA rules
 - d. NGR, Posts and Timbers, and Beams and Stringers portions of the WCLIB rules
 - e. NGR, Selects and Finish, Boards, Posts and Timbers, and Beams and Stringers portions of the NeLMA rules
 - f. NGR, Selects and Finish, Boards, Mouldings, Posts and Timbers, and Beams and Stringers portions of the NSLB rules
2. Approved to supervise glued and machine graded lumber.
3. Approved to provide heat treatment audit services under all rules.



Southern Pine Inspection Bureau (SPIB)

P.O. Box 10915
Pensacola, FL 32524-0915

850.434.2611
fax: 850.433.5594
e-mail: spib@spib.org

1. SPIB is a rules writing agency
2. Approval of rules they publish and as an inspection agency including mill supervisory service under:
 - a. SPIB rules
 - b. Southern Pine graded under WHPA Moulding Stock and Shop Lumber rules
 - c. NGR, Posts and Timbers, and Beams and Stringers portions of NeLMA rules
 - d. NGR, Posts and Timbers, and Beams and Stringers portions of NSLB rules
 - e. NGR, Posts and Timbers, and Beams and Stringers portions of WCLIB rules
 - f. NGR, Western Patio Decking, Posts and Timbers, and Beams and Stringers portions of WHPA rules
 - g. NGR, Posts and Timbers, and Beams and Stringers portions of NLGA rules
3. Approved to supervise glued and machine graded lumber.
4. Approved to provide heat treatment audit services under all rules.



Stafford Inspection and Consulting, LLC (SIWP)

14418 Roxane Drive
Orlando, FL 32832

407.380.7914
fax: 407.380.8914
e-mail: info@staffordinspection.com

1. Approval as an inspection agency including mill supervisory service under:
 - a. NGR, Timbers, Stress Rated Boards, Radius Edge Decking, Finish, and Boards portions of SPIB rules
 - b. NGR, Selects and Common Boards, Shop and Mouldings, Western Patio Decking, Beams and Stringers, and Posts and Timbers portions of the WHPA rules
 - c. NGR and Alternate Decking portions of the WCLIB rules
 - d. NGR, Paragraph 112-Selects, Paragraph 113-Commons, Posts and Timbers, and Beams and Stringers portions of the NLGA rules
 - e. NGR, Section 7-Selects and Commons, Posts and Timbers, and Beams and Stringers portions of the NSLB rules
 - f. NGR, Section 7-Selects and Commons, Posts and Timbers, and Beams and Stringers portions of the NeLMA rules
2. Approved to provide heat treatment audit services under all rules.

AUDITED BY

TP NO.1 KD-19
000 HT SYP

Timber Products Inspection (TP)

P.O. Box 919
Conyers, GA 30012

770.922.8000
fax: 770.922.1290
e-mail: dconner@tpinspection.com

1. Approval as an inspection agency including mill supervisory service under:
 - a. SPIB rules
 - b. RIS rules
 - c. WCLIB rules
 - d. WWPA rules
 - e. NGR, Posts and Timbers, and Beams and Stringers, and Section 6-Eastern White Pine Board Grades portions of the NeLMA rules
 - f. NGR, paragraph 112-Selects, and paragraph 113-Commons portions of the NLGA rules
 - g. NGR portion of the NSLB rules
2. Approved to supervise glued and machine graded lumber.
3. Approved to provide heat treatment audit services under all rules.

AUDITED BY

TP HT 000 
000 HT HT

001



001



HT

HT

West Coast Lumber Inspection Bureau (WCLIB)

P.O. Box 23145
Portland, OR 97281-3145

503.639.0651
fax: 503.684.8928
e-mail: info@wclib.org

MILL 10
 NO. 2
DOUG FIR S-DRY

1. WCLIB is a rules writing agency.
2. Approval of rules they publish and as an inspection agency including mill supervisory service under:
 - a. WCLIB rules
 - b. RIS rules
 - c. WWPA rules
 - d. NLGA rules
 - e. NGR, Scaffold Plank, Radius Edge Decking, Finish and Boards portions of the SPIB rules
3. Approved to supervise glued and machine graded lumber.
4. Approved to provide heat treatment audit services under all rules.



2

S-DRY



Western Wood Products Association (WWPA)

522 SW Fifth Avenue, Suite 500
Portland, OR 97204-2122

503.224.3930
fax: 503.224.3934
e-mail: info@wwpa.org

1. WWPA is a rules writing agency.
2. Approval of rules they publish and as an inspection agency including mill service under:
 - a. WWPA rules
 - b. WCLIB rules
 - c. NLGA rules
 - d. RIS rules
 - e. NGR and Scaffold Plank portions of the SPIB rules
 - f. Section 6.2-Eastern White Pine Common Board Grades of the NeLMA rules
3. Approved to supervise glued and machine graded lumber.
4. Approved to provide heat treatment audit services under all rules.

Appendix D



National Lumber Grades Authority (NLGA)
Suite 105, 13401 – 108th Ave.
Surrey, BC V3T 5T3

604.584.2393
fax: 604.584.2890
e-mail: info@nlga.org

The NLGA is the rules writing agency for Canada. The following Canadian agencies have been accredited by the Board of Review of the American Lumber Standard Committee as inspection agencies including mill supervisory service as indicated below.

A.F.P.A.® 00
S-P-F NLGA
KD-HT 1

Alberta Forest Products Association (AFPA)
Suite 900, 10707 100 Avenue
Edmonton, AB T5J 3M1

780.452.2841
fax: 780.455.0505
e-mail: info@albertaforestproducts.ca

1. Approved as an inspection agency including mill supervisory service under:
 - a. NLGA rules
2. Approved to supervise glued and machine graded lumber.
3. Approved to provide heat treatment audit services under all rules.



Canadian Mill Services Association (CMSA)
#200, 601-6th Street
New Westminster, BC V3L 3C1

604.523.1288
fax: 604.523.1289
e-mail: sing@canserve.org

1. Approved as an inspection agency including mill supervisory service under:
 - a. NLGA rules
 - b. NGR portion of WWPA rules for Douglas fir, larch, and SPF(S)
2. Approved to supervise glued and machine graded lumber.
3. Approved to provide heat treatment audit services under all rules.

CMSA® 100 HT

CSI No 1
000 S-DRY
HEM-FIR(N)

Canadian Softwood Inspection Agency, Inc. (CSI)
MacDonald Inspection Services (MI)

Brookwood RPO
P.O. Box 61599
Langley, BC V3A 8C8

604.535.6192
888.331.8200
fax: 604.535.6412
e-mail: info@canadiansoftwood.com



1. Approved as an inspection agency including mill supervisory service under:
 - a. NLGA rules
 - b. NGR, Posts and Timbers, and Beams and Stringers portions of WWPA rules
 - c. NGR, Posts and Timbers, and Beams and Stringers portions of WCLIB rules
2. Approved to supervise glued and machine graded lumber.
3. Approved to provide heat treatment audit services under all rules.

CFPA® 00
S-P-F S-DRY
CONST

Central Forest Products Association (CFPA)
10709 Jasper Ave., # 500
Edmonton, AB T5J 3N3

780.452.2841
780.455.0505
e-mail: info@albertaforestproducts.ca

1. Approved as an inspection agency including mill supervisory service under:
 - a. NLGA rules
 - b. NGR portion of NeLMA rules
2. Approved to supervise glued and machine graded lumber.
3. Approved to provide heat treatment audit services under all rules.

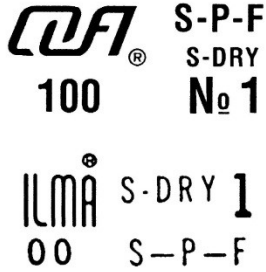

Council of Forest Industries (COFI)

Suite 1501, 700 West Pender St.
Pender Place I Business Building
Vancouver, BC V6C 1G8

604.684.0211
fax: 604.687.4930
e-mail: info@cofi.org

Southern Region

360-1855 Kirschner Rd.
Kelowna, BC V1Y 4N7

250.860.9663
fax: 250.860.0009
e-mail: crooks@cofi.org
desrosier@cofi.org

Northern Region

400-1488 Fourth Ave.
Prince George, BC V2L 4Y2

250.564.5136
fax: 250.860.0009
e-mail: routledge@nfpa.bc.ca

1. Approved as an inspection agency including mill supervisory service under:
 - a. NLGA rules
 - b. NGR portion of WWPA rules
2. Approved to supervise glued and machine graded lumber.
3. Approved to provide heat treatment audit services under all rules.

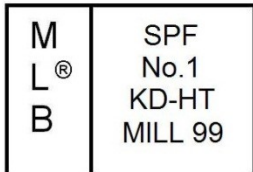

Maritime Lumber Bureau (MLB)

P.O. Box 459
Amherst, NS B4H 4A1

902.667.3889
fax: 902.667.0401
e-mail: mlb@ns.sympatico.ca

1. Approved as an inspection agency including mill supervisory service under:
 - a. NLGA rules
 - b. NGR and Section 6-Eastern White Pine Board Grades portions of the NeLMA rules
2. Approved to supervise glued lumber.
3. Approved to provide heat treatment audit services under all rules.

NFLD.LUMBER



Newfoundland and Labrador Lumber Producers Association (NLPA)

P.O. Box 8
Glovertown, NF A0G 2L0

709.533.2206
fax: 709.533.2611
e-mail: nllpa@nf.sympatico.ca

1. Approved as an inspection agency including mill supervisory service under:
 - a. NLGA rules
2. Approved to provide heat treatment audit services under all rules.



Ontario Forest Industries Association (OFIA) – Home of CLA Grading and Inspection

10 King Street East, Suite 300
Toronto, ON M5C 1C3

416.368.6188
fax: 416.368.5445
e-mail: info@ofia.com

1. Approved as an inspection agency including mill supervisory service under:
 - a. NLGA rules
 - b. NGR and Section 6-Eastern White Pine Board Grades portions of NeLMA rules
2. Approved to supervise glued and machine graded lumber.
3. Approved to provide heat treatment audit services under all rules.

O.L.M.A.® 01-1
CONST. S-DRY
SPRUCE - PINE - FIR

Ontario Lumber Manufacturers Agency (OLMA)
244 Viau Road
Noelville, ON P0M 2N0

705.618.3403
fax: 705.898.3403
e-mail: aboucher@olma.ca

1. Approved as an inspection agency including mill supervisory service under:
 - a. NLGA rules
 - b. NGR and Section 6-Eastern White Pine Board Grades portions of the NeLMA rules
2. Approved to supervise glued and machine graded lumber.
3. Approved to provide heat treatment audit services under all rules.

 **NLGA RULE**
No 1
S-DRY
S-P-F

Pacific Lumber Inspection Bureau (PLIB)
British Columbia Division
P.O. Box 19118
Fourth Avenue Postal Outlet
Vancouver, BC V6K 4R8

BC tel/fax: 604.732.1782
US tel: 253.835.3344
e-mail: info@plib.org

1. Approval as an inspection agency including mill supervisory service under:
 - a. NLGA rules
 - b. WCLIB rules
 - c. WWPA rules
 - d. RIS rules
2. Approved to supervise glued and machine graded lumber.
3. Approved to provide heat treatment audit services under all rules.

 **S-P-F**
1
000 S-DRY

Quebec Forest Industry Council (QFIC)
1175 Lavigerie Avenue, Suite 200
Ste-Foy, QB G1V 4P1

418.657.7916
fax: 418.657.3365
e-mail: info@cifq.qc.ca

1. Approved as an inspection agency including mill supervisory service under:
 - a. NLGA rules
 - b. NGR and paragraph 6.2 Commons portions of the NeLMA rules
2. Approved to supervise glued and machine graded lumber.
3. Approved to provide heat treatment audit services under all rules.

The following agencies are accredited to provide heat treatment service only. Typical stamps are shown.



American Wood Inspection Services (AWIS)

29767 CR250 540.558.8380
Carrollton, MO 64633 e-mail: brandon@heatinspectations.com

1. Approval as an inspection agency including mill supervisory service under:
 - a. Heat Treatment portion only of the NeLMA, NSLB, RIS, SPIB, WCLIB, WWPA, and NLGA rules



Carolina Inspection Services, Inc. (CIS)

5910 Morgan Park Dr. 866.753.5738
Monroe, NC 28110 704.624.1996
fax: 704.624.1946
e-mail: cis@carolinainspection.com

1. Approval as an inspection agency including mill supervisory service under:
 - a. Heat Treatment portion only of the NeLMA, NSLB, RIS, SPIB, WCLIB, WWPA, and NLGA rules



Conway & Robison, LLC (C&R)

P.O. Box 1508 678.642.4036
Sharpsburg, GA 30277 e-mail: jason@cr-inspect.com

1. Approval as an inspection agency including mill supervisory service under:
 - a. Heat Treatment portion only of the NeLMA, NSLB, RIS, SPIB, WCLIB, WWPA, and NLGA rules



Export Wood Packaging Inspection Service (EWPI)

1115 E Street 719.539.3123
Salida, CO 81201 877.400.7750
fax: 719.344.2353
e-mail: contact@exportwoodpi.com

1. Approval as an inspection agency including mill supervisory service under:
 - a. Heat Treatment portion only of the NeLMA, NSLB, RIS, SPIB, WCLIB, WWPA, and NLGA rules

000

HT LIWP®

Lee Inspection & Consulting Services, Inc. (LIWP)

2207 California Plaza, #3B
Bossier City, LA 71171

800.508.6232
fax: 800.508.5531
e-mail: dkirk.stokes@gmail.com

1. Approval as an inspection agency including mill supervisory service under:
 - a. Heat Treatment portion only of the NeLMA, NSLB, RIS, SPIB, WCLIB, WWPA, and NLGA rules

0000

HT 

0000

HT MFPA

0000

HT 

Missouri Forest Products Association (MFPA)

505 East State Street
Jefferson City, MO 65101

573.634.3252
fax: 573.636.2591
e-mail: moforest@moforest.org

1. Approval as an inspection agency including mill supervisory service under:
 - a. Heat Treatment portion only of the NeLMA, NSLB, RIS, SPIB, WCLIB, WWPA, and NLGA rules

001

HT 



Package Research Laboratory (PRL)

41 Pine Street
Rockaway, NJ 07866

973.627.4405
fax: 973.627.4407
e-mail: ddixon@package-testing.com

1. Approval as an inspection agency including mill supervisory service under:
 - a. Heat Treatment portion only of the NeLMA, NSLB, RIS, SPIB, WCLIB, WWPA, and NLGA rules

000  HT

Wood Research and Development, LLC (WRD)

PO Box 70
Jefferson, OR

541.752.0188
fax: 503.385.8493
e-mail: admin@woodrandd.com

1. Approval as an inspection agency including mill supervisory service under:
 - a. Heat Treatment portion only of the NeLMA, NSLB, RIS, SPIB, WCLIB, WWPA, and NLGA rules

INTERPRETING GRADE STAMPS

With few exceptions (see note), all approved grade stamps include the following five elements:

Visually Graded Lumber¹:

(a) TRADEMARK®	(c) Grade Designation
(b) Mill Identification	(d) (e) Species Seasoning

- a. *Trademark* – indicates identity of agency quality supervision
 - b. *Mill Identification* – product manufacturer name, brand or assigned mill number
 - c. *Grade Designation* – grade name (number or abbreviation)
 - d. *Species Identification* – name or abbreviation of individual species or species combination
 - e. *Condition of Seasoning*^a – moisture content classification at time of surfacing
 1. *S-Dry* – 19% maximum moisture content
 2. *MC15* – 15% maximum moisture content
 3. *KD* – kiln dried to moisture content indicated in grading rules
 4. *S-Gm* – over 19% moisture content (unseasoned)
- ^a – *HT* – designation for Heat Treated - while not a seasoning designation, the abbreviation HT may be found in conjunction with the above seasoning abbreviations (see notes below). The HT definition can be found in the grading rules.

Machine Graded Lumber¹:

Grade stamps on machine graded lumber include the five elements listed above for visually graded lumber. Grade designations for the two types of machine graded lumber, machine stress rated (MSR) lumber and machine evaluated lumber (MEL), are distinctive from those used for visually graded lumber grades.

Machine Stress Rated Lumber (MSR) Stamp:

(b) Mill Identification	(d) Species	(e) Seasoning
(a) TRADEMARK®	(c) #### Fb - #.#E	
Machine Rated		

- MSR grade designations are composed of the assigned extreme fiber in bending (Fb or f) in psi and the assigned modulus of elasticity (E) in millions of pounds per square inch. Examples include 1650f-1.5E; 2100f-1.8E; and 2400f-2.0E.
- The phrase "Machine Rated" or "MSR" is also required on machine stress rated lumber stamps.

Machine Evaluated Lumber (MEL) Stamp:

(a) TRADEMARK®	(b) Mill Identification
(d) Species	(e) Seasoning
M – xx	
#### Fb	#.# E #### Ft

- MEL grade designations use the format, M-xx; where xx indicates a one or two digit number. Examples include M-12; M-15; and M-19.
- In addition, the assigned extreme fiber in bending (Fb or f) in psi, the assigned modulus of elasticity (E) in millions of pounds per square inch, and the assigned tension parallel to grain (Ft) in psi are required elements on machine evaluated lumber stamps.

Glued Lumber¹:

(a) TRADEMARK®	(b) Mill Identification
(d) Species	(e) Seasoning
(c) Grade Identification (Type Glue/Appropriate Use)	

Grade stamps on glued lumber include all the information indicated for visually graded lumber. In addition, the grade stamp includes a designation or abbreviation indicating the type of glue joint and appropriate use. Examples include "Stud Use Only", "Vertical Use Only", "Certified End Joint", "Certified Exterior Joints", "Heat Resistant Adhesive", and "Non-heat Resistant Adhesive".

¹ Grade Stamp Layout – The placement of the required elements within a grade stamp may vary, depending on the preferences of the specific supervising agency. The sample grade stamp facsimiles that accompany the agency listing herein provide a good example of the typical placement of elements preferred by that particular agency. Contact the agency, whose trademark appears on the lumber, for specific information related to the agency's grade stamping policies.

Note: Grade stamps for timbers are not required to include the condition of seasoning. An approved grade stamp may include only a) trademark, b) mill identification, c) HT designation. Grade stamps are permitted to include information that is not required, so long as the additional information is not confusing, misleading or deceptive. Contact the agency, whose trademark appears on the lumber, for specific information related to the agency's grade stamping policy.

American Lumber Standard Committee, Incorporated
 P.O. Box 210 Germantown, MD 20875-0210
 301.972.1700 fax 301.540.8004 e-mail: alsc@alsc.org url: www.alsc.org

American Lumber Standard Committee, Incorporated

R.K. Caron, Chairman
 T.F. Brodie, Vice Chairman
 H.B. Sager, Treasurer
 T.D. Searles, President

P.O. Box 210
 Germantown, Maryland 20875-0210
 Telephone: 301.972.1700
 Fax: 301.540.8004
 E-Mail: alscc@alscc.org

ACCREDITED AGENCIES FOR SUPERVISORY AND LOT INSPECTION OF PRESSURE TREATED WOOD PRODUCTS

July 2013

(this list supercedes all previous lists)

Agencies Accredited by the Board of Review of the American Lumber Standard Committee, Incorporated and Typical Quality Marks

Interpreting a Quality Mark

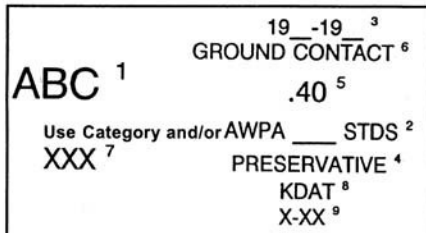

- 1 – The identifying symbol, logo, or name of the accredited agency.
- 2 – The applicable American Wood Protection Association (AWPA) standard and Use Category.
- 3 – The year of treatment if required by AWPA Standard/Use Category.
- 4 – The preservative used, which may be abbreviated.
- 5 – The preservative retention.
- 6 – The exposure category (e.g. Above Ground, Ground Contact, etc.).
- 7 – The company name and location of home office; or company name and number; or company number.
- 8 – If applicable, moisture content after treatment.
- 9 – If applicable, length, and/or class.

As specified below for particular agencies, some or all of the following American Wood Protection Association use-category standards are used by American Lumber Standard Committee, Incorporated accredited agencies which supervise facilities which pressure treat wood products:

Service Conditions for AWWA Use Category Designations

USE CATEGORY	SERVICE CONDITIONS	USE ENVIRONMENT	COMMON AGENTS OF DETERIORATION	TYPICAL APPLICATIONS
UC1 INTERIOR/ DRY	Interior construction Above Ground Dry	Continuously protected from weather or other sources of moisture	Insects only	Interior construction and furnishings
UC2 INTERIOR/ DAMP	Interior construction Above Ground Damp	Protected from weather, but may be subject to sources of moisture	Decay fungi and insects	Interior construction
UC3A ABOVE GROUND Protected	Exterior construction Above Ground Coated & rapid water runoff	Exposed to all weather cycles, not exposed to prolonged wetting	Decay fungi and insects	Coated millwork, siding and trim
UC3B ABOVE GROUND Exposed	Exterior construction Above Ground Uncoated or poor water runoff	Exposed to all weather cycles including prolonged wetting	Decay fungi and insects	Decking, deck joists, railings, fence pickets, uncoated millwork

Appendix D

UC4A GROUND CONTACT General Use	Ground Contact or Fresh Water Non-critical components	Exposed to all weather cycles, normal exposure conditions	Decay fungi and insects	Fence, deck, and guardrail posts, crossties & utility poles (low decay areas)
UC4B GROUND CONTACT Heavy Duty	Ground Contact or Fresh Water Critical components or difficult replacement	Exposed to all weather cycles, high decay potential includes salt water splash	Decay fungi and insects with increased potential for biodeterioration	Permanent wood foundations, building poles, horticultural posts, crossties & utility poles (high decay areas)
UC4C GROUND CONTACT Extreme Duty	Ground Contact or Fresh Water Critical structural components	Exposed to all weather cycles, severe environments extreme decay potential	Decay fungi and insects with extreme potential for biodeterioration	Land & Freshwater piling, foundation piling, crossties & utility poles (severe decay areas)
UC5A MARINE USE Northern Waters	Salt or brackish water and adjacent mud zone Northern waters	Continuous marine exposure (salt water)	Salt water organisms	Piling, bulkheads, bracing
UC5B MARINE USE Central Waters	Salt or brackish water and adjacent mud zone NJ to GA, south of San Francisco	Continuous marine exposure (salt water)	Salt water organisms including creosote tolerant <i>Limnoria tripunctata</i>	Piling, bulkheads, bracing
UC5C MARINE USE Southern Waters	Salt or brackish water and adjacent mud zone South of GA, Gulf Coast, Hawaii, and Puerto Rico	Continuous marine exposure (salt water)	Salt water organisms including <i>Martesia, Sphaeroma</i>	Piling, bulkheads, bracing

*** For additional information concerning the AWP Use Category treatment requirements contact the American Wood Protection Association, P.O. Box 361784, Birmingham, AL 35236-1784 (Telephone 205.733.4077, Fax 205.733.4075, e-mail: email@awpa.com, url: www.awpa.com).

As specified in the following tables, some or all of the following preservatives are used:

KEY TO THE FOLLOWING TABLES

CCA	- chromated copper arsenate	1	- sawn material and plywood
ACZA	- ammoniacal copper zinc arsenate	2	- plywood only
ACC	- acid copper chromate	3	- sawn material only
ACQ	- alkaline copper quat.	R	- round commodities
CuN	- copper nahpthenate		
PCP	- pentachlorophenol	SP	- southern pine
CR	- creosote and/or solutions	RP	- red pine
SBX	- borates	PP	- ponderosa pine
CA	- copper azole	HF	- hem-fir
CX	-copper HDO	DF	- coastal Douglas fir
KDS	-alkaline copper betaine	LP	- lodgepole pine
EL2	-DCOI + Imidacloprid	WH	- western hemlock
PTI	-propiconazole tebuconazole imidacloprid	RDP	- radiata pine
		CP	- caribbean pine
		EWP	- eastern white pine
		JP	- jack pine

Appendix D

ACCREDITED AGENCY AND ADDRESSES

TYPICAL QUALITY MARK

TABLE OF COMMODITIES, BY SPECIES AND PRESERVATIVE (see key)

Bode Inspection, Inc.
 P.O. Box 307
 Beaverton, OR 97075-0307
 503.590.3555
 503.590.2802 (f)
 e-mail: bodeins@comcast.net



	HF	DF	WH
CCA	1	1,R	R
ACZA	1	1,R	R
ACC	1	1,R	R
ACQ	1	1,R	
CuN	1	1,R	R
PCP	1	1,R	R
CR	1	1,R	R
CA	3	1	3
SBX	1	1	1

Southern Pine Inspection Bureau
 4555 Spanish Trail
 Pensacola, FL 32504
 850.434.5011
 850.434.5388 (f)
 e-mail: spib@spib.org

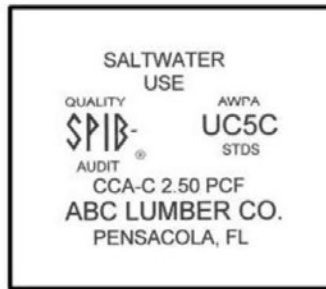

ALL AWPA APPLICABLE SPECIES	
CCA	1,R
PCP	R
CR	R
ACQ	1
ACZA	1
ACC	1
SBX	1
CA	1,R

Southern Pine Inspection Bureau maintains a laboratory accredited for the analysis of wood samples pressure treated with the following preservative(s): CCA, ACC, ACZA, SBX, PCP, CR, CA, and ACQ.

Timber Products Inspection
 P.O. Box 919
 Conyers, GA 30012
 770.922.8000
 770.922.1290 (f)
 e-mail: jwilliams@tpinspection.com



ALL AWPA APPLICABLE SPECIES	
CCA	1,R
ACZA	1,R
ACC	1,R
ACQ	1,R
CuN	1,R
PCP	1,R
CR	1,R
SBX	1
CA	1,R

Timber Products Inspection maintains a laboratory accredited for the analysis of wood samples pressure treated with the following preservative(s): CCA, ACZA, ACC, ACQ, CuN, PCP, CR, SBX, and CA.

American Lumber Standard Committee, Incorporated
 P.O. Box 210 Germantown, MD 20875-0210
 301.972.1700 fax 301.540.8004 e-mail: alscl@alsc.org url: www.alsc.org

AREAS OF PLANE FIGURES

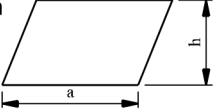
	<p>Square Diagonal = $d = s\sqrt{2}$ Area = $s^2 = 4b^2 = 0.5d^2$ Example: $s = 6$; $b = 3$; Area = $(6)^2 = 36$ Ans. $d = 6 \times 1.414 = 8.484$ Ans.</p>
	<p>Rectangle and Parallelogram</p>  <p>Area = ab or $b\sqrt{d^2 - b^2}$ Example. $a = 6$; $b = 3$. Area = $3 \times 6 = 18$ Ans.</p>
	<p>Trapezoid Area = $\frac{1}{2}h(a + b)$ Example: $a = 2$; $b = 4$; $h = 3$ Area = $\frac{1}{2} \times 3(2 + 4) = 9$ Ans.</p>
	<p>Trapezium Area = $\frac{1}{2}[a(h + h') + bh' + ch]$ Example: $a = 4$; $b = 2$; $c = 2$; $h = 3$; $h' = 2$. Area = $\frac{1}{2}[4(3 + 2) + (2 \times 2) + (2 \times 3)] = 15$ Ans.</p>
	<p>Triangles Both formulas apply to both figures. Area = $\frac{1}{2}bh$ Example: $h = 3$; $b = 5$ Area = $\frac{1}{2}(3 \times 5) = 7\frac{1}{2}$ Ans. Area = $\sqrt{S(S - a)(S - b)(S - c)}$ where $S = \frac{a + b + c}{2}$ Example: $a = 2$; $b = 3$; $c = 4$ $S = \frac{2 + 3 + 4}{2} = 4.5$; Area = $\sqrt{4.5(4.5 - 2)(4.5 - 3)(4.5 - 4)} = 2.9$ Ans.</p>
	<p>Regular Polygons</p> <p>Area</p> <ul style="list-style-type: none"> 5 sides = $1.720477S^2 = 3.63271r^2$ 6 sides = $2.598150S^2 = 3.46410r^2$ 7 sides = $3.633875S^2 = 3.37101r^2$ 8 sides = $4.828427S^2 = 3.31368r^2$ 9 sides = $6.181875S^2 = 3.27573r^2$ 10 sides = $7.694250S^2 = 3.24920r^2$ 11 sides = $9.365675S^2 = 3.22993r^2$ 12 sides = $11.196300S^2 = 3.21539r^2$ <p>n = number of sides; r = short radius; S = length of side; R = long radius. Area = $\frac{n}{4}S^2 \cot \frac{180^\circ}{n} = \frac{n}{2}R^2 \sin \frac{360^\circ}{n} = nr^2 \tan \frac{180^\circ}{n}$</p>

AREAS OF PLANE FIGURES

Circle

$\pi = 3.1416$; A = area; d = diameter

p = circumference or periphery; r = radius

$$p = \pi d = 3.1416d \quad p = 2\sqrt{\pi A} = 3.54\sqrt{A}$$

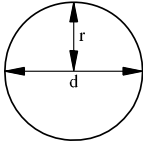

$$p = 2\pi r = 6.283r \quad p = \frac{2A}{r} = \frac{4A}{d}$$

$$A = \frac{\pi d^2}{4} = 0.7854d^2 \quad A = \frac{p^2}{4\pi} = \frac{p^2}{12.57}$$

$$A = \pi r^2 = 3.1416r^2 \quad A = \frac{pr}{2} = \frac{pd}{4}$$

Circular Ring

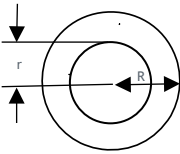

$$A = \pi(R^2 - r^2) = 3.1416(R^2 - r^2)$$

$$A = 0.7854(D^2 - d^2) = 0.7854(D - d)(D + d)$$

Area (A) = difference in areas between the inner and outer circles.

Example: R = 4; r = 2

$$A = 3.1416(4^2 - 2^2) = 37.6992 \text{ Ans.}$$

Quadrant

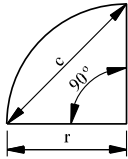

$$A = \frac{\pi r^2}{4} = 0.7854r^2 = 0.3927c^2$$

Example. r = 3; c = chord.

$$\text{Area} = 0.7851 \times 3^2 = 7.0686 \text{ Ans.}$$

Segment

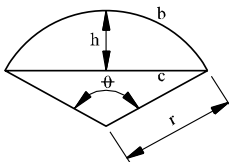

b = length of arc; θ = angle in degrees; c = chord = $\sqrt{4(2hr - h^2)}$

$$A = \frac{1}{2}[br - c(r - h)] = \pi r^2 \frac{\theta}{360} - \frac{c(r-h)}{2}$$

When θ is greater than 180° then $\frac{c}{2} \times$ the difference between r and h is added to the fraction: $\frac{\pi r^2 \theta}{360}$.

Example: R = 3; $\theta = 120^\circ$; h = 1.5

$$A = 3.1416 \times 3^2 \times \frac{120}{360} - \frac{5.196(3 - 1.5)}{2} = 5.5278 \text{ Ans.}$$

AREAS OF PLANE FIGURES

Sector

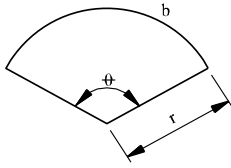

$$A = \frac{br}{2} = \pi r^2 \frac{\theta}{360}$$

$\theta = \text{angle in degrees}; b = \text{length of arc}$

Example: $r = 3; \theta = 120^\circ$

$$A = 3.1416 \times 3 = 3.1416 \times 3^2 \times \frac{120}{360} = 9.428 \text{ Ans}$$

Spandrel

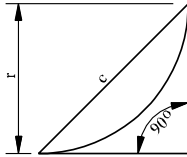

$$\text{Area} = 0.2146r^2 = 0.1073c^2$$

Example: $r = 3$

$$\text{Area} = 0.2146 \times 3^2 = 1.9314 \text{ Ans.}$$

Parabola

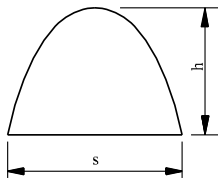

$l = \text{length of curved line} = \text{periphery} - s$

$$l = \frac{s^2}{8h} \left[\sqrt{c(1+c)} + 2.0326 \times \log(\sqrt{c} + \sqrt{1+c}) \right] \text{ where } c = \left(\frac{4h}{s}\right)^2$$

$$\text{Area} = \frac{2}{3} sh$$

Example: $s = 3; h = 4$

$$\text{Area} = \frac{2}{3} \times 3 \times 4 = 8 \text{ ans}$$

Ellipse

$$\text{Area} = \pi ab = 3.1416ab$$

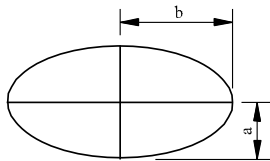

$$C = 2\pi \sqrt{\frac{a^2+b^2}{2}} \text{ (close approximation)}$$

Example: $a = 3; b = 4$

$$\text{Area} = 3.1416 \times 3 \times 4 = 37.6992 \text{ Ans.}$$

$$C = 2 \times 3.1416 \sqrt{\frac{3^2+4^2}{2}} = 6.2832 \times 3.5355 = 22.21 \text{ Ans.}$$

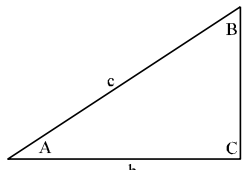
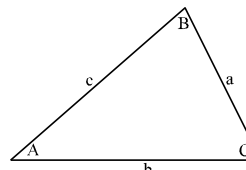
TRIGONOMETRIC SOLUTION OF TRIANGLES		
	$S = \frac{a + b + c}{2}$	
Given:	Sought:	Formulae:
RIGHT-ANGLED TRIANGLES		
a, c	A, B, b	$\sin A = \frac{a}{c}, \cos B = \frac{a}{c}, b = \sqrt{c^2 - a^2}$
	Area	$Area = \frac{a}{2} \sqrt{c^2 - a^2}$
a, b	A, B, c	$\tan A = \frac{a}{b}, \tan B = \frac{b}{a}, c = \sqrt{a^2 + b^2}$
	Area	$Area = \frac{ab}{2}$
A, a	B, b, c	$B = 90^\circ - A, \quad b = a \cot A, \quad c = \frac{a}{\sin A}$
	Area	$Area = \frac{a^2 \cot A}{2}$
A, b	B, a, c	$B = 90^\circ - A, \quad a = b \tan A, \quad c = \frac{b}{\cos A}$
	Area	$Area = \frac{b^2 \tan A}{2}$
A, c	B, a, b	$B = 90^\circ - A, \quad a = c \sin A, \quad b = c \cos A$
	Area	$Area = \frac{c^2 \sin A \cos A}{2} \text{ or } \frac{c^2 \sin 2A}{4}$
OBLIQUE-ANGLED TRIANGLES		
a, b, c	A	$\sin \frac{1}{2}A = \sqrt{\frac{(s-b)(s-c)}{bc}}, \cos \frac{1}{2}A = \sqrt{\frac{s(s-a)}{bc}}, \tan \frac{1}{2}A = \sqrt{\frac{(s-b)(s-c)}{s(s-a)}}$
	B	$\sin \frac{1}{2}B = \sqrt{\frac{(s-a)(s-b)}{ac}}, \cos \frac{1}{2}B = \sqrt{\frac{s(s-c)}{ac}}, \tan \frac{1}{2}B = \sqrt{\frac{(s-a)(s-c)}{s(s-b)}}$
	C	$\sin \frac{1}{2}C = \sqrt{\frac{(s-a)(s-b)}{ab}}, \cos \frac{1}{2}C = \sqrt{\frac{s(s-c)}{ab}}, \tan \frac{1}{2}C = \sqrt{\frac{(s-a)(s-b)}{s(s-c)}}$
	Area	$Area = \sqrt{s(s-a)(s-b)(s-c)}$
a, A, B	b, c	$b = \frac{a \sin B}{\sin A}, \quad c = \frac{a \sin C}{\sin A} = \frac{a \sin(A+B)}{\sin A}$
	Area	$Area = \frac{1}{2} ab \sin C = \frac{a^2 \sin B \sin C}{2 \sin A}$

TRIGONOMETRIC SOLUTION OF TRIANGLES

a, b, A	B	$\sin B = \frac{b \sin A}{a}$
	C	$c = \frac{a \sin C}{\sin A} = \frac{b \sin C}{\sin B} = \sqrt{a^2 + b^2 - 2ab \cos C}$
	Area	$Area = \frac{1}{2} ab \sin C$
a, b, C	A	$\tan A = \frac{a \sin C}{b - a \cos C}, \quad \tan \frac{1}{2}(A - B) = \frac{a-b}{a+b} \cot \frac{1}{2}C$
	C	$c = \sqrt{a^2 + b^2 - 2ab \cos C} = \frac{a \sin C}{\sin A}$
	Area	$Area = \frac{1}{2} ab \sin C$
$a^2 = b^2 + c^2 - 2bc \cos A, \quad b^2 = a^2 + c^2 - 2ac \cos B, \quad c^2 = a^2 + b^2 - 2ab \cos C$		

PROBABLE COMPRESSIVE STRENGTH OF CONCRETE CYLINDERS

$$S^{28} = S^7 + 30 \sqrt{S^7}$$

where: S^{28} = approximate 28 day strength.

S^7 = known 7 day strength.

For approximating strengths at other ages from known strengths at various ages the following table may be used.

AGE (days)	PROBABLE COMPRESSIVE STRENGTH (pounds per square inch)								
	100	1550	2250	2900	4150	4720	5400	5970	6560
90	1500	2180	2830	3440	4050	4620	5280	5840	6430
80	1460	2110	2740	3350	3950	4510	5150	5710	6290
70	1390	2030	2640	3250	3830	4380	5000	5550	6110
60	1330	1940	2540	3120	3690	4220	4840	5370	5930
55	1290	1890	2470	3050	3610	4140	4750	5270	5820
50	1250	1840	2410	2970	3520	4050	4640	5170	5700
45	1200	1780	2330	2890	3420	3950	4520	5040	5570
40	1150	1700	2250	2790	3310	3830	4400	4910	5430
38	1130	1670	2220	2760	3280	3790	4350	4860	5380
36	1110	1640	2190	2720	3230	3740	4300	4800	5310
34	1080	1610	2140	2670	3180	3680	4220	4720	5240
32	1050	1580	2100	2620	3120	3620	4160	4650	5170
30	1030	1540	2050	2560	3060	3560	4090	4570	5090
28	1000	1500	2000	2500	3000	3500	4000	4500	5000
26	960	1450	1950	2450	2930	3410	3930	4400	4900
24	920	1400	1890	2380	2850	3340	3840	4300	4800
22	890	1350	1830	2310	2780	3250	3750	4200	4700
20	850	1300	1770	2240	2700	3160	3640	4100	4590
19	830	1270	1730	2200	2650	3110	3590	4040	4510
18	800	1240	1690	2150	2600	3050	3520	3980	4450
17	780	1200	1650	2100	2550	3000	3460	3910	4380
16	750	1170	1600	2050	2490	2940	3400	3830	4300
15	720	1130	1550	2000	2430	2870	3310	3770	4210
14	690	1090	1500	1950	2360	2800	3250	3690	4130
13	660	1050	1450	1890	2300	2740	3180	3600	4050
12	630	1000	1400	1820	2230	2660	3090	3500	3960
11	590	950	1350	1750	2150	2570	3000	3400	3850
10	550	900	1280	1680	2070	2490	2900	3300	3730
9	510	840	1200	1590	1980	2380	2780	3170	3600
8	460	780	1130	1500	1880	2280	2650	3050	3460
7	400	700	1040	1380	1750	2120	2500	2890	3280
6	340	600	920	1260	1610	1980	2340	2700	3100

CONVERSION TABLES

MULTIPLY	BY	TO OBTAIN
ACRES	43560	SQUARE FEET
BARRELS OF CEMENT	376	POUNDS OF CEMENT
BAGS OF CEMENT	94	POUNDS OF CEMENT (1 CU FT)
CUBIC FEET	7.48052	U.S. GALLONS
CUBIC FEET	1728	CUBIC INCHES
CUBIC FEET	62.4	POUNDS OF WATER
CUBIC INCHES	0.0005787	CUBIC FEET
CUBIC INCHES	0.004329	U.S. GALLONS
CUBIC YARDS	27	CUBIC FEET
CUBIC YARDS	46656	CUBIC INCHES
CUBIC YARDS	201.97	U.S. GALLONS
FATHOMS	6	FEET
FEET	0.3048	METERS
FEET PER SECOND	0.68182	MILES PER HOUR
METERS	3.281	FEET
METERS	39.37	INCHES
METERS	1.094	YARDS
MILES	5280	FEET
MILES PER HOUR	88	FEET PER MINUTE
MILES PER HOUR	1.46667	FEET PER SECOND
POUNDS OF WATER	0.01602	CUBIC FEET
POUNDS OF WATER	27.68	CUBIC INCHES
POUNDS OF WATER	0.12	U.S. GALLONS
SQUARE FEET	144	SQUARE INCHES
SQUARE MILES	640	ACRES
SQUARE YARDS	9	SQUARE FEET
SQUARE FEET	0.0002066	ACRES
TONS (SHORT)	2000	POUNDS
TONS (LONG)	2240	POUNDS

**CONVERSION FACTORS
LENGTH MEASUREMENTS**

UNITS	INCHES	FEET	YARDS	RODS	MILES	METERS
1 Inch	1	0.08333	0.027778	0.005051	0.0000157828	0.0254
1 Foot	12	1	0.3333	0.060606	0.00018939	0.304801
1 Yard	36	3	1	0.181818	0.000568182	0.914402
1 Rod	198	16.5	5.5	1	0.003125	5.029216
1 Mile (Stat)	63360	5280	1760	320	1	1609.347
1 Meter	39.37	3.280833	1.093611	0.198838	0.00062137	1
1 Link	7.92	0.66	0.22	0.04	0.000125	0.201168
1 Chain	792	66	22	4	0.0125	20.117
1 Station	1200	100	33.33	6.060606	0.0189394	30.4801
1 Furlong	7920	660	220	40	0.125	201.168
1 Mile (Naut)	72913	6076.103	2025.366	368.248	1.15078	1852
1 Millimeter	0.03937	0.003281	0.001094	0.000199	--	0.001
1 Centimeter	0.3937	0.032808	0.010936	0.001988	--	0.01
1 Kilometer	--	3280.833	1093.611	198.836	0.621370	1000

**CONVERSION MEASUREMENTS
WEIGHT MEASUREMENTS**

UNITS	OUNCES	POUNDS	TONS (SHORT)	TONS (LONG)	KILOGRAMS	TONS (METRIC)
1 OUNCE	1	0.0625	---	---	0.028349	---
1 POUND	16	1	0.0005	0.000464	0.4535924	0.00045359
1 TON (SHORT)	32000	2000	1	0.892857	907.18486	0.907185
1 TON (LONG)	35840	2240	1.12	1	1016.047	1.016047
1 KILOGRAM	35.27396	2.204622	0.0011023	0.0009842	1	0.001
1 TON (METRIC)	35273.96	2204.62	1.10231	0.98421	1000	1
1 HBRDWEIGHT (SHORT)	1600	100	0.05	0.04663	45.3592	0.045359
1 HBRDWEIGHT (LONG)	1792	112	0.056	0.05	50.8023	0.050802
1 GRAIN	0.0022857	---	---	---	---	---
1 GRAN	0.0352739	0.002204	---	---	0.001	---
1 MILLIGRAM	---	---	---	---	0.000001	---

**CONVERSION FACTORS
AREA MEASUREMENTS**

UNITS	SQUARE INCHES	SQUARE FEET	SQUARE YARDS	SQUARE RODS	ACRES	SQUARE MILES	SQUARE METERS
1 SQUARE INCH	1	0.006944	0.0007716	---	---	---	0.00064516
1 SQUARE FOOT	144	1	0.11111	0.0036731	---	---	0.09290341
1 SQUARE YARD	1296	9	1	0.033058	0.0002066	---	0.8361307
1 SQUARE ROD	39204	272.25	30.25	1	0.00625	---	25.29295
1 ACRE	---	43560	4840	160	1	0.0015625	4046.873
1 SQUARE MILE	---	---	3097600	102400	640	1	2589998
1 SQUARE METER	1550	10.76387	1.195985	0.0395367	0.0002471	---	1
1 SQUARE LINK	62.7264	0.4356	0.0484	0.0016	0.00001	---	0.040468
1 SQUARE CHAIN	627264	4356	484	16	0.1	---	404.689
1 SQUARE	14400	100	11.1111	0.367309	0.0022956	---	9.29034
1 SECTION	---	---	3097600	102400	640	1	2589998
1 SQUARE CENTIMETER	0.1549997	0.0010764	0.0001196	---	---	---	0.0001
1 HECTARE	---	107638.7	11959.85	395.367	2.471044	0.003861	10000
1 SQUARE KILOMETER	---	---	1195985	39536.7	247.1044	0.3861006	1000000

**CONVERSION FACTORS
VOLUME MEASUREMENTS**

UNITS	CUBIC INCHES	CUBIC FEET	CUBIC YARDS	PINTS (LIQUID)	QUARTS (LIQUID)	GALLONS (U.S.)	LITERS (1000 cc)
1 CUBIC INCH	1	0.000579	0.0000214	0.034632	0.017316	0.004329	0.016387
1 CUBIC FOOT	1728	1	0.037037	59.844	29.922	7.4805	28.31625
1 CUBIC YARD	46656	27	1	1615.8	807.9	201.975	764.54
1 PINT (LIQUID)	28.875	0.016710	0.000619	1	0.5	0.125	0.473168
1 QUART (LIQUID)	57.75	0.033420	0.001238	2	1	0.25	0.946333
1 GALLON (U.S.)	231	0.1336805	0.004951	8	4	1	3.78533
1 LITER (1000 cc)	61.025	0.035316	0.001308	2.11336	1.056682	0.264178	1
1 GILL	7.21876	0.004177	0.000155	0.25	0.125	0.03125	0.118292
1 PINT (DRY)	33.6003	0.019445	0.000720	1.163647	0.581823	0.145456	0.550599
1 QUART (DRY)	67.200625	0.038889	0.001440	2.32730	1.163646	0.290912	1.10120
1 QUART (IMPERIAL)	69.35503	0.040135	0.001486	2.4019	1.200953	0.300238	1.13650
1 GALLON (IMPERIAL)	277.4201	0.16054	0.0059457	9.60762	4.80381	1.20095	4.54609
1 PECK	537.605	0.311114	0.011523	18.61835	9.309177	2.327294	8.809586
1 BUSHEL (U.S.)	2150.42	1.2444	0.046089	74.47341	37.23670	9.3092	35.238329
1 BOARD FOOT	144	0.08333	0.003086	4.987012	2.493506	0.623376	2.3597
1 CORD	221184	128	4.74074	7660.051	3830.025	957.506	3624.48
1 PETROLEUM BARREL	9701.975	5.614569	0.207947	336	168	42	158.9839
1 BARREL (U.S. LIQUID)	7276.370	4.21086	0.15596	252	126	31.5	119.237695
1 CUBIC METER	61023.38	35.314445	1.307943	2113.4	1056.7	264.178	999.973
1 CUBIC CENTIMETER	0.061024	0.0000353	...	0.002113	0.001057	0.0002642	0.000999

EQUIVALENT WEIGHTS OF AGGREGATES

POUNDS PER CUBIC FOOT	POUNDS PER CUBIC YARD		TONS PER CUBIC YARD		CUBIC YARDS PER TON		POUNDS PER CUBIC FOOT	POUNDS PER CUBIC YARD		TONS PER CUBIC YARD		CUBIC YARDS PER TON	
	POUNDS PER CUBIC YARD	TONS PER CUBIC YARD	POUNDS PER CUBIC YARD	TONS PER CUBIC YARD	POUNDS PER CUBIC FOOT	TONS PER CUBIC FOOT		POUNDS PER CUBIC YARD	TONS PER CUBIC YARD	POUNDS PER CUBIC FOOT	TONS PER CUBIC FOOT	POUNDS PER CUBIC YARD	TONS PER CUBIC YARD
60	1620	0.81	1.23	94.4	2550	1.28	0.78	0.78					
65	1755	0.88	1.14	96.3	2600	1.30	0.77	0.77					
70	1890	0.95	1.06	98.1	2650	1.33	0.75	0.75					
75	2025	1.01	0.99	100.0	2700	1.35	0.74	0.74					
80	2160	1.08	0.93	101.9	2750	1.38	0.73	0.73					
85	2295	1.15	0.87	103.7	2800	1.40	0.71	0.71					
90	2430	1.22	0.82	105.6	2850	1.43	0.70	0.70					
95	2565	1.28	0.78	107.4	2900	1.45	0.69	0.69					
100	2700	1.35	0.74	109.3	2950	1.48	0.68	0.68					
105	2835	1.42	0.71	111.1	3000	1.50	0.67	0.67					
110	2970	1.49	0.67	113.0	3050	1.53	0.66	0.66					
115	3105	1.55	0.64	114.8	3100	1.55	0.65	0.65					
120	3240	1.62	0.62	116.7	3150	1.58	0.63	0.63					
125	3375	1.69	0.59	118.5	3200	1.60	0.63	0.63					
130	3510	1.76	0.57	120.4	3250	1.63	0.62	0.62					
135	3645	1.82	0.55	122.2	3300	1.65	0.61	0.61					
140	3780	1.89	0.53	124.1	3350	1.68	0.60	0.60					
66.7	1800	0.90	1.11	125.9	3400	1.70	0.59	0.59					
68.5	1850	0.93	1.08	127.6	3450	1.73	0.58	0.58					
70.4	1900	0.95	1.05	129.6	3500	1.75	0.57	0.57					
72.2	1950	0.97	1.03	131.5	3550	1.78	0.56	0.56					
74.1	2000	1.00	1.00	133.3	3600	1.80	0.56	0.56					
75.9	2050	1.03	0.98	135.2	3650	1.83	0.55	0.55					
77.8	2100	1.05	0.85	137.0	3700	1.85	0.54	0.54					
79.6	2150	1.08	0.93	138.0	3750	1.88	0.53	0.53					
81.5	2200	1.10	0.91	140.7	3800	1.90	0.52	0.52					
83.3	2250	1.13	0.89	142.6	3850	1.93	0.52	0.52					
85.2	2300	1.15	0.87	144.4	3900	1.95	0.51	0.51					
87.0	2350	1.18	0.85	146.3	3950	1.98	0.51	0.51					
88.9	2400	1.20	0.83	148.1	4000	2.0	0.50	0.50					
90.7	2450	1.23	0.82	150.0	4050	2.03	0.49	0.49					
92.6	2500	1.25	0.80										

**TEMPERATURE-VOLUME CORRECTIONS
FOR EMULSIFIED ASPHALTS**

Legend: t = observed temperature in degrees Celsius
(Fahrenheit)

M = multiplier for correcting volumes to the
basis of 15.6°C (60°F)

°C	°F	M*	°C	°F	M*	°C	°F	M*
10.0	50	1.00250	35.0	95	.99125	57.8	136	.98100
10.6	51	1.00225	35.6	96	.99100	58.3	137	.98075
11.1	52	1.00200	36.1	97	.99075	58.9	138	.98050
11.7	53	1.00175	36.7	98	.99050	59.4	139	.98025
12.2	54	1.00150	37.2	99	.99025	60.0	140	.98000
12.8	55	1.00125	37.8	100	.99000	60.6	141	.97975
13.3	56	1.00100	38.3	101	.98975	61.1	142	.97950
13.9	57	1.00075	38.9	102	.98950	61.7	143	.97925
14.4	58	1.00050	39.4	103	.98925	62.2	144	.97900
15.0	59	1.00025	40.0	104	.98900	62.8	145	.97875
15.6	60	1.00000	40.6	105	.98875	63.3	146	.97850
16.1	61	.99975	41.1	106	.98850	63.9	147	.97825
16.7	62	.99950	41.7	107	.98825	64.4	148	.97800
17.2	63	.99925	42.2	108	.98800	65.0	149	.97775
17.8	64	.99900	42.8	109	.98775	65.6	150	.97750
18.3	65	.99875	43.3	110	.98750	66.1	151	.97725
18.9	66	.99850	43.9	111	.98725	66.7	152	.97700
19.4	67	.99825	44.4	112	.98700	67.2	153	.97675
20.0	68	.99800	45.0	113	.98675	67.8	154	.97650
20.6	69	.99775	45.6	114	.98650	68.3	155	.97625
21.1	70	.99750	46.1	115	.98625	68.9	156	.97600
21.7	71	.99725	46.7	116	.98600	69.4	157	.97575
22.2	72	.99700	47.2	117	.98575	70.0	158	.97550
22.8	73	.99675	47.8	118	.98550	70.6	159	.97525
23.3	74	.99650	48.3	119	.98525	71.1	160	.97500
23.9	75	.99625	48.9	120	.98500	71.7	161	.97475
24.4	76	.99600	49.4	121	.98475	72.2	162	.97450
25.0	77	.99575	50.0	122	.98450	72.8	163	.97425
25.6	78	.99550	50.6	123	.98425	73.3	164	.97400
26.1	79	.99525	51.1	124	.98400	73.9	165	.97375
26.7	80	.99500	51.7	125	.98375	74.4	166	.97350
27.2	81	.99475	52.2	126	.98350	75.0	167	.97325
27.8	82	.99450	52.8	127	.98325	75.6	168	.97300
28.3	83	.99425	53.3	128	.98300	76.1	169	.97275
28.9	84	.99400	53.9	129	.98275	76.7	170	.97250
29.4	85	.99375	54.4	130	.98250	77.2	171	.97225
30.0	86	.99350	55.0	131	.98225	77.8	172	.97200
30.6	87	.99325	55.6	132	.98200	78.3	173	.97175
31.1	88	.99300	56.1	133	.98175	78.9	174	.97150
31.7	89	.99275	56.7	134	.98150	79.4	175	.97125
32.2	90	.99250	57.2	135	.98125			
32.8	91	.99225						
33.3	92	.99200						
33.9	93	.99175						
34.4	94	.99150						

*Multiplier (M) for °C is a close approximation.